



ROHDE & SCHWARZ

Test and Measurement
Division

Operating Manual

RADIOCOMMUNICATION

SERVICE MONITOR

CMS 50 / 52 / 54 / 57

840.0009.50 / .52 / .54 / .57

Printed in the Federal
Republic of Germany

Contents

Index

| | |
|--|---|
| Operation of Basic Instrument and Options | 1 |
| Operation of Autorun/Printer Control | 2 |
| Operation of VOR / ILS | 3 |

Certified Quality System ISO 9001

DQS REG. NO 1954-04

Sehr geehrter Herr/Dame,

Sehr geehrter Kunde,

Sie haben sich für den Kauf eines Rohde & Schwarz-Produktes entschieden. Hiermit erhalten Sie ein nach modernsten Fertigungsmethoden hergestelltes Produkt. Es wurde nach den Regeln unseres Qualitätsmanagementsystems entwickelt, gefertigt und geprüft. Das Rohde & Schwarz-Qualitätsmanagementsystem ist nach ISO 9001 zertifiziert.

Dear Mr./Mrs./Ms/Ms.

Dear Customer,

You have decided to buy a Rohde & Schwarz product. You are thus assured of receiving a product that is manufactured using the most modern methods available. This product was developed, manufactured and tested in compliance with our quality management system standards.

The Rohde & Schwarz quality management system is certified according to ISO 9001.

Cher Monsieur/Madame,

Cher client,

Vous avez choisi d'acheter un produit Rohde & Schwarz. Vous disposez donc d'un produit fabriqué d'après les méthodes les plus avancées. Le développement, la fabrication et les tests respectent nos normes de gestion qualité.

Le système de gestion qualité de Rohde & Schwarz a été homologué conformément à la norme ISO 9001.



ROHDE & SCHWARZ
ROHDE & SCHWARZ

Support Center

Telefon / Telephone: (0180) 512 42 42

Fax: (+89) 41 29 - 137 77

e-mail: CustomerSupport@rsd.rohde-schwarz.com

Für technische Fragen zu diesem Rohde & Schwarz-Gerät steht Ihnen ab sofort unsere Hotline der Rohde & Schwarz Vertriebs-GmbH, Support Center, zur Verfügung.

Unser Team bespricht mit Ihnen Ihre Fragen und sucht Lösungen für Ihre Probleme.

Die Hotline ist Montag bis Freitag von 8.00 bis 17.00 Uhr besetzt.

Bei Anfragen außerhalb der Geschäftszeiten hinterlassen Sie bitte eine Nachricht oder senden Sie eine Notiz per Fax oder e-mail. Wir setzen uns dann baldmöglichst mit Ihnen in Verbindung.

 Möchten Sie über Neuerungen und Updates zu einem bestimmten Gerät informiert werden, senden Sie bitte eine kurze e-mail unter Angabe des Gerätes. Sie erhalten dann regelmäßig die aktuellen Informationen zugesandt.

Should you have any technical questions concerning this Rohde & Schwarz product, please contact the hotline of Rohde & Schwarz Vertriebs-GmbH, Support Center.

Our hotline team will answer your questions and find solutions to your problems.

You can reach the hotline Monday through Friday from 8:00 until 17:00.

If you need assistance outside office hours, please leave a message or send us a fax or e-mail. We will contact you as soon as possible.

 If you wish to receive the latest news about and updates for a specific instrument, please send us a short e-mail indicating the instrument. We will then send you up-to-date information on a regular basis.



ROHDE & SCHWARZ



Certificate No.: 9502178

This is to certify that:

| Equipment type | Order No. | Designation |
|----------------|--------------|--------------------------------|
| CMS50 | 0840.0009.50 | Radiocommunic. Service Monitor |
| CMS52 | 0840.0009.52 | " |
| CMS54 | 0840.0009.54 | " |
| CMS57 | 0840.0009.57 | " |

complies with the provisions of the Directive of the Council of the European Union on the approximation of the laws of the Member States

- relating to electrical equipment for use within defined voltage limits
(73/23/EEC revised by 93/68/EEC)
- relating to electromagnetic compatibility
(89/336/EEC revised by 91/263/EEC, 92/31/EEC)

Conformity is proven by compliance with the following standards:

EN61010-1 : 1991
EN50081-1 : 1992
EN50082-1 : 1992

Affixing the EC conformity mark as from 1995

ROHDE & SCHWARZ GmbH & Co. KG
Mühldorfstr. 15, D-81671 München

Munich, 01.12.95

Central Quality Management FS-QZ / Becker



ROHDE & SCHWARZ
EC Certificate of Conformity



Certificate No.: 9502172

This is to certify that:

| Equipment type | Order No. | Designation |
|----------------|--------------|----------------------------------|
| CMS-B1 | 0840.9406.02 | OCXO Reference Oscillator |
| CMS-B13 | 0841.1009.02 | Signalling Unit |
| CMS-B2 | 1001.6809.02 | OCXO Reference Oscillator |
| CMS-B20 | 0841.1209.02 | U/I DC Meter |
| CMS-B21 | 1001.6509.02 | Programmable Modem |
| CMS-B22 | 1001.6750.02 | 10 MHz Ref. Frequency Inp./Outp. |
| CMS-B27 | 1032.1250.02 | ATIS/CDCSS Coder and Decoder |
| CMS-B30 | 1001.6909.02 | RS 232-Interface |
| CMS-B31 | 1001.7005.02 | Additional RF In/Output |
| CMS-B32 | 1001.7905.02 | 100 W RF Power Meter |
| CMS-B33 | 1032.0290.02 | 300 Hz Lowpass Filter |
| CMS-B34 | 1032.1350.02 | 13 dBm Output |
| CMS-B35 | 1075.5441.02 | RF Millivoltmeter |
| CMS-B38 | 1065.5003.02 | Autopilot Generator |
| CMS-B39 | 1032.0090.02 | 600 Ohm AF Transf. |

complies with the provisions of the Directive of the Council of the European Union on the approximation of the laws of the Member States

- relating to electromagnetic compatibility
(89/336/EEC revised by 91/263/EEC, 92/31/EEC)

Conformity is proven by compliance with the following standards:

EN50081-1 : 1992
EN50082-1 : 1992

Affixing the EC conformity mark as from 1995

ROHDE & SCHWARZ GmbH & Co. KG
Mühldorfstr. 15, D-81671 München

Munich, 02.04.96

Central Quality Management FS-QZ / Becker



ROHDE & SCHWARZ
EC Certificate of Conformity



Certificate No.: 9502181

This is to certify that:

| Equipment type | Order No. | Designation |
|----------------|--------------|-------------------------|
| CMS-B5 | 0841.0502.xx | Control Interface |
| CMS-B53 | 1032.0890.02 | Signalling Unit |
| CMS-B54 | 1032.0748.02 | IEC/IEEE Bus Interface |
| CMS-B55 | 1032.0790.02 | Centronics Interface |
| CMS-B59 | 1032.0990.02 | Duplex Modulation Meter |
| CMS-B60 | 1075.5006.02 | Protection for Input 2 |
| CMS-B9 | 0840.9506.02 | Duplex Modulation Meter |

complies with the provisions of the Directive of the Council of the European Union on the approximation of the laws of the Member States

- relating to electromagnetic compatibility
(89/336/EEC revised by 91/263/EEC, 92/31/EEC)

Conformity is proven by compliance with the following standards:

EN50081-1 : 1992
EN50082-1 : 1992

Affixing the EC conformity mark as from 1995

ROHDE & SCHWARZ GmbH & Co. KG
Mühldorfstr. 15, D-81671 München

Munich, 29.11.95







Central Quality Management FS-QZ / Becker

Safety Instructions

This unit has been designed and tested in accordance with the EC Certificate of Conformity and has left the manufacturer's plant in a condition fully complying with safety standards.

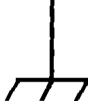
To maintain this condition and to ensure safe operation, the user must observe all instructions and warnings given in this operating manual.

Safety-related symbols used on equipment and documentation from R&S:

| | | | | | | | |
|---|---|---|---|---|--|---|---|
|  |  |  |  |  |  |  |  |
| Observe operating instructions | Weight indication for units >18 kg | PE terminal | Ground terminal | Danger! Shock hazard | Warning! Hot surfaces | Ground | Attention! Electrostatic sensitive devices require special care |

1. The unit may be used only in the operating conditions and positions specified by the manufacturer. Unless otherwise agreed, the following applies to R&S products:
IP degree of protection 2X, pollution severity 2 overvoltage category 2, only for indoor use, altitude max. 2000 m.
The unit may be operated only from supply networks fused with max. 16 A.
Unless specified otherwise in the data sheet, a tolerance of $\pm 10\%$ shall apply to the nominal voltage and of $\pm 5\%$ to the nominal frequency.
2. For measurements in circuits with voltages $V_{rms} > 30\text{ V}$, suitable measures should be taken to avoid any hazards.
(using, for example, appropriate measuring equipment, fusing, current limiting, electrical separation, insulation).
3. If the unit is to be permanently wired, the PE terminal of the unit must first be connected to the PE conductor on site before any other connections are made. Installation and cabling of the unit to be performed only by qualified technical personnel.
4. For permanently installed units without built-in fuses, circuit breakers or similar protective devices, the supply circuit must be fused such as to provide suitable protection for the users and equipment.
5. Prior to switching on the unit, it must be ensured that the nominal voltage set on the unit matches the nominal voltage of the AC supply network.
If a different voltage is to be set, the power fuse of the unit may have to be changed accordingly.
6. Units of protection class I with disconnectible AC supply cable and appliance connector may be operated only from a power socket with earthing contact and with the PE conductor connected.
7. It is not permissible to interrupt the PE conductor intentionally, neither in the incoming cable nor on the unit itself as this may cause the unit to become electrically hazardous.
Any extension lines or multiple socket outlets used must be checked for compliance with relevant safety standards at regular intervals.
8. If the unit has no power switch for disconnection from the AC supply, the plug of the connecting cable is regarded as the disconnecting device. In such cases it must be ensured that the power plug is easily reachable and accessible at all times (length of connecting cable approx. 2 m). Functional or electronic switches are not suitable for providing disconnection from the AC supply.
If units without power switches are integrated in racks or systems, a disconnecting device must be provided at system level.
9. Applicable local or national safety regulations and rules for the prevention of accidents must be observed in all work performed.
Prior to performing any work on the unit or opening the unit, the latter must be disconnected from the supply network.
Any adjustments, replacements of parts, maintenance or repair may be carried out only by authorized R&S technical personnel.
Only original parts may be used for replacing parts relevant to safety (eg power switches, power transformers, fuses). A safety test must be performed after each replacement of parts relevant to safety.
(visual inspection, PE conductor test, insulation-resistance, leakage-current measurement, functional test).

continued overleaf

Safety Instructions

10. Ensure that the connections with information technology equipment comply with IEC950 / EN60950.
11. Lithium batteries must not be exposed to high temperatures or fire.
Keep batteries away from children.
If the battery is replaced improperly, there is danger of explosion. Only replace the battery by R&S type (see spare part list).
Lithium batteries are suitable for environmentally-friendly disposal or specialized recycling. Dispose them into appropriate containers, only.
Do not short-circuit the battery.
12. Equipment returned or sent in for repair must be packed in the original packing or in packing with electrostatic and mechanical protection.
13. Electrostatics via the connectors may damage the equipment. For the safe handling and operation of the equipment, appropriate measures against electrostatics should be implemented.
14. The outside of the instrument is suitably cleaned using a soft, lint-free dustcloth. Never use solvents such as thinners, acetone and similar things, as they may damage the front panel labeling or plastic parts.
15. Any additional safety instructions given in this manual are also to be observed.

Radiocommunication Service Monitor CMS50 / CMS52 / CMS54 / CMS57

Operating Manual

Edition 04 / June 1997

REVISION STATE OF PAGES

| Order number / Page number | Revision index / Date of edition | Order number / Page number | Revision index / Date of edition |
|-------------------------------|-------------------------------------|-------------------------------|-------------------------------------|
| 1078.1953.12 1 | 04 06 / 97 | | |
| 840.0009.52 0 | E-11 06 / 97 | | |
| 840.0009 CE | E-2 12 / 95 | | |
| 840.0009 CE.1 | E-1 04 / 96 | | |
| 840.0009 CE.2 | E-1 11 / 95 | | |
| 840.0009.52 1 | E-11 06 / 97 | | |
| 840.0009.52 3 ... 7 | E-11 06 / 97 | | |
| 840.0009.52 1.1 ... 1.2 | E-2 06 / 97 | | |
| 1007.8690 1 ... 8 | E-2 02 / 96 | | |
| 840.0009.52 2.1 ... 2.124 | E-9 06 / 97 | | |
| 840.0009.52 3.1 | E-9 06 / 97 | | |
| 840.0009.52 2.200 | D/E-1 10 / 92 | | |
| 840.9306.02 1, 3 ... 29 | E-5 06 / 97 | | |
| 840.0009.57 1, 3 ... 31 | E-7 06 / 97 | | |

Adressen/Addresses

FIRMENSITZ/HEADQUARTERS

Telefon/Phone
Telefax
E-mail

ROHDE & SCHWARZ GmbH & Co. KG

Mühlendorfstraße 15 · 81671 München +49 89 41 29-0
Postfach 801469 · 81614 München +49 89 41 29-12164
Internet: www.rohde-schwarz.com -

WERKE/PLANTS

ROHDE & SCHWARZ Messgerätebau GmbH

Riedbachstraße 58 · 87700 Memmingen +49 83 31 10 8-0
Postfach 16 52 · 87686 Memmingen +49 83 31 10 81 124 -

ROHDE & SCHWARZ GmbH & Co. KG

Werk Teisnach +49 99 23 8 57-0
Kaikenrieder Straße 27 · 94244 Teisnach +49 99 23 8 571-1 74
Postfach 11 49 · 94240 Teisnach -

ROHDE & SCHWARZ GmbH & Co. KG - Werk Köln

Graf-Zeppelin-Straße 18 · 51147 Köln +49 22 03 49-0
Postfach 98 02 60 · 51130 Köln +49 22 03 49-51 3 08 -

TOCHTERUNTERNEHMEN/SUBSIDIARIES

ROHDE & SCHWARZ Vertriebs-GmbH

Mühlendorfstraße 15 · 81671 München +49 89 4129-120 07
Postfach 801469 · 81614 München +49 89 4129-135 67
customersupport@rohde-schwarz.com

ROHDE & SCHWARZ International GmbH

Mühlendorfstraße 15 · 81671 München +49 89 4129-120 05
Postfach 80 14 60 · 81614 München +49 89 4129-135 97 -

ROHDE & SCHWARZ Engineering and Sales GmbH

Mühlendorfstraße 15 · 81671 München +49 89 4129-137 11
Postfach 80 14 29 · 81614 München +49 89 4129-137 23 -

R&S BICK Mobilfunk GmbH

Im Landerfeld 7 · 31848 Bad Münder +49 50 42 9 98-0
Postfach 20 62 · 31844 Bad Münder +49 50 42 9 98-105
rsbick@rsbick.rohde-schwarz.com

ROHDE & SCHWARZ FTK GmbH

Wendenschloßstraße 168, Haus 28 +49 30 6 58 91-122
12557 Berlin +49 30 65 550-221 -

SIT Gesellschaft für Systeme

der Informationstechnik mbH +49 30 6 58 84-2 22
Wendenschloßstraße 168, Haus 28 +49 30 6 58 84-1 83
12557 Berlin sit.info@sit.rohde-schwarz.com

Zweigniederlassungen der Rohde & Schwarz Vertriebs-GmbH/Branch offices of Rohde & Schwarz Vertriebs-GmbH

Zweigniederlassung Berlin

Ernst-Reuter-Platz 10 · 10587 Berlin (+49 30) 34 79 48-0
Postfach 100620 · 10566 Berlin (+49 30) 34 79 48-48
customersupport@rohde-schwarz.com

Zweigniederlassung Büro Bonn

Josef-Wirmer-Straße 1-3 · 53123 Bonn (+49 2 28) 918 90-0
Postfach 140264 · 53057 Bonn (+49 2 28) 25 50 87
customersupport@rohde-schwarz.com

Zweigniederlassung Hamburg

Steilshooper Allee 47 · 22309 Hamburg (+49 40) 63 29 00-0
Postfach 602240 · 22232 Hamburg (+49 40) 630 78 70
customersupport@rohde-schwarz.com

Zweigniederlassung Köln

Graf-Zeppelin-Straße 18 · 51147 Köln (+49 22 03) 807-0
Postfach 900149 · 51111 Köln (+49 22 03) 807-50
customersupport@rohde-schwarz.com

Zweigniederlassung Mitte

Siemensstraße 20 (+49 61 02) 20 07-0
63263 Neu-Isenburg (+49 61 02) 80 00 40
customersupport@rohde-schwarz.com

Zweigniederlassung München

Mühlendorfstraße 15 · 81671 München (+49 89) 41 86 95-0
Postfach 801449 · 81614 München (+49 89) 40 47 64
customersupport@rohde-schwarz.com

Zweigniederlassung Nürnberg

Donaustraße 36 (+49 9 11) 64203-0
90451 Nürnberg (+49 9 11) 64203-33
customersupport@rohde-schwarz.com

Zweigniederlassung Telekommunikation

Siemensstraße 20 (+49 61 02) 20 07-0
63263 Neu-Isenburg (+49 61 02) 20 07-12
customersupport@rohde-schwarz.com

ADRESSEN WELTWEIT/ADDRESSES WORLDWIDE

Algeria

ROHDE & SCHWARZ Bureau d'Alger (2) 59 24 53
5 B, Place de Laperrière (2) 69 46 08
16035 Hydra-Alger -

Argentina

Precisión Electrónica SRL (14) 331 16 85
Av. Julio A. Roca 710 - Piso 6 (14) 334 51 11
1067 Buenos Aires preelctr@satlink.com

Australia

ROHDE & SCHWARZ Sales (2) 8845 4100
(AUSTRALIA) Pty. Ltd. (2) 9738 3988
Unit 6, 2-8 South Street Service (2) 8845 4188
Rydalmere, N.S.W. 2116 (2) 9638 0832
sales@rsaus.rohde-schwarz.com
service@rsaus.rohde-schwarz.com

Austria

ROHDE & SCHWARZ-ÖSTERREICH (1) 6 02 61 41
Ges. m. b. H. (1) 6 02 61 41-14
Sonnleithnergasse 20 office@rsoe.rohde-schwarz.com
1100 Wien

Azerbaijan

ROHDE & SCHWARZ Azerbaijan 12 93 31 38
Liaison Office Baku 12 93 03 14
Azerbaijan Avenue 35 -
370139 Baku

Baltic

Countries siehe/see Denmark

Bangladesh

Business International Ltd. (2) 881 06 53
Corporation Office (2) 882 82 91
House No: 95/A, Block 'F'
Road No: 4, Banani
Dhaka - 1213 -

Belgium

ROHDE & SCHWARZ BELGIUM N.V. (2) 7 21 50 02
Excelsiorlaan 31 Bus 1 (2) 7 25 09 36
1930 Zaventem info@rsb.rohde-schwarz.com

Bolivia

siehe auch/see also Argentina

RIBCO LTDA. (2) 32 84 03
Av. Mariscal Santa Cruz 1392 (2) 39 30 47
Ed. Cámara Nacional gibatta@caoba.entelnet.bo
de Comercio
Piso 10, Of.1010-1011
La Paz

Brazil

ROHDE & SCHWARZ DO BRASIL LTDA.
Av. Alfredo Egidio de (11) 56 41 12 00
Souza Aranha, 177 (11) 56 41 78 10
1º andar - Santo Amaro
04726-170 São Paulo- SP

Adressen/Addresses

| | | | | | |
|---------------------------|--|--|------------------|--|--|
| Brunei | GKL Equipment PTE. Ltd. #11-01 BP Tower 396, Alexandra Road Singapore 119954 Republic of Singapore | 276 06 26 276 06 29 gkleqpt@signet.com.sg | Finland | Orbis Oy P.O. B. 15 00421 Helsinki | (9) 47 88 30 (9) 53 16 04 info@orbis.fi |
| Bulgaria | ROHDE & SCHWARZ Representation Office Bulgaria 39, Fridtjof Nansen Blvd. 1000 Sofia | (2) 963 43 34 (2) 963 21 97 rohdebg@rsoe.com | France | ROHDE & SCHWARZ FRANCE Immeuble "Le Newton" 9-11, rue Jeanne Braconnier 92366 Meudon-la-Forêt Cédex | (1) 41 36 10 00 (1) 41 36 11 10 - |
| Canada | Kommunikationstechnik/Communications Equipment: ROHDE & SCHWARZ CANADA Inc. 555 March Rd. Kanata, Ontario K2K 2M5 | (613) 592 80 00 (613) 592 80 09 - | | Niederlassung/Subsidiary Rennes: ROHDE & SCHWARZ FRANCE Sigma 1 Rue du Bignon 35135 Chantepie | (2) 99 51 97 00 (2) 99 41 91 31 - |
| | Messtechnik/T & M Equipment: TEKTRONIX CANADA, Inc. 3280 Langstaff Road, Unit 1 Concord, Ontario L4K 5B6 | (416) 747 50 00 (905) 760 72 41 - | | Niederlassung/Subsidiary Toulouse: ROHDE & SCHWARZ FRANCE Technoparc 3 B.P.501 31674 Labège Cédex Büros/Offices: Aix-en-Provence | (5) 61 39 10 69 (5) 61 39 99 10 - |
| Chile | DYMEQ Ltda. Avenida Larrain 6666 Santiago | (2) 277 50 50 (2) 227 87 75 dymeq@entelchile.net | | Lyon | (4) 94 07 39 94 (4) 94 07 55 11 (4) 78 29 88 10 (4) 78 29 94 71 |
| China | ROHDE & SCHWARZ Representative Office Beijing Parkview Center, Room 602 No. 2 Jiangtai Road, Chao Yang District Beijing 100016, P. R. China | (10) 64 31 28 28 (10) 64 37 98 88 - | | Nancy | (3) 83 54 51 29 (3) 83 55 39 51 |
| Colombia | Ferrostaal de Colombia Av. Eldorado Nro. 97-03 Interior 2 Santafé de Bogotá, D.C. | (1) 415 77 00 (1) 413 18 06 mc_fsc@multiphone.net.co | Ghana | KOP Engineering Ltd. P.O. Box 11012 3rd Floor Akai House, Osu Accra | (21) 77 99 13 (21) 22 47 69 |
| Costa Rica | siehe/see Mexico (EPSA) | | Greece | MERCURY SA. 6, Loukianou Str. 10675 Athens | (1) 722 92 13 (1) 721 51 98 mercury@hol.gr |
| Croatia | siehe/see Austria | | Guatemala | siehe/see Mexico (EPSA) | |
| Republic of Cyprus | HINIS TELECAST LTD. Agiou Thoma 18 Kiti Larnaca 7550 | (4) 42 51 78 (4) 42 46 21 | Honduras | siehe/see Mexico (EPSA) | |
| Czech Republic | ROHDE & SCHWARZ – Praha, s.r.o. Pod Kastany 3 160 00 Praha 6 | (2) 24 32 20 14 (2) 24 31 70 43 rohdecz@rsoe.com | Hong Kong | Schmidt & Co. (HK) Ltd. 9/F North Somerset House Taikoo Place 979 King's Road Quarry Bay, Hong Kong | 25 07 03 33 28 27 56 56 frankwong@shk.schmidtgroup.com |
| Denmark | ROHDE & SCHWARZ DANMARK A/S Ejby Industrivej 40 2600 Glostrup | 43 43 66 99 43 43 77 44 RSDK@post1.tele.dk | Hungary | ROHDE & SCHWARZ Budapesti Iroda Etele ut. 68 1115 Budapest | (1) 203 02 82 (1) 203 02 82 rohdehu@rsoe.com |
| Ecuador | REPRESENTACIONES MANFRED WEINZIERL Guanguiltagua 72 (39-93) Urbanización Jardines del Batán Quito | (2) 25 22 51 (2) 25 22 51 mweinzierl@accessinter.net | Iceland | siehe/see Denmark | |
| Egypt | U.A.S. Universal Advanced Systems 31 Manshiet El Bakry St., Heliopolis 11341 Cairo | (202) 455 67 44 (202) 256 17 40 uas@intouch.com | India | ROHDE & SCHWARZ India Pvt. Ltd. 244, Okhla Industrial Estate Phase - III New Delhi 110 020 | (11) 683 74 84 |
| El Salvador | siehe/see Mexico (EPSA) | | Indonesia | P.T. REKANUSA SOLUSI Menara Rajawali, 24th floor Jl Mega Kuningan Lot # 5.1 Kawasan Mega Kuningan Jakarta 12950 | (21) 576 16 02 (21) 576 16 04 - |
| Estonia | ROHDE & SCHWARZ DANMARK A/S Estonian Branch Office Narva mnt. 13 10151 Tallinn | (6) 14 31 20 (6) 14 31 21 | Iran | ROHDE & SCHWARZ IRAN Liaison Office - Reg. N° RFC 1947 Dr. Beheschty Ave., Pakistan Ave., 12th Street N° 1 Tehran 15317 | (21) 8 73 02 82 (21) 8 73 02 83 - |

Adressen/Addresses

| | | | | |
|------------------------------|---|-------------------------------------|--|--|
| Ireland | siehe/see Great Britain | | | |
| Italy | ROHDE & SCHWARZ ITALIA S.p.a. | (6) 41 59 81 | | |
| | Via Tiburtina 1182 | (6) 41 59 82 70 | | |
| | 00156 Roma | - | | |
| | Centro Direzionale Lombardo | (2) 95 70 41 | | |
| | Via Roma 108 | (2) 95 30 27 72 | | |
| | 20060 Cassina de' Pecchi (MI) | | | |
| Japan | ADVANTEST Corporation | (3) 33 42 75 53 | | |
| | RS Sales Department | (3) 53 22 72 70 | | |
| | Shinjuku-NS Building, 4-1 | yoshimu@inst.advantest.co.jp | | |
| | Nishi-Shinjuku | | | |
| | Tokyo 163-08, Japan | | | |
| Jordan | Middle East Development | (6) 465 96 71 | | |
| | c/o Jordan Crown Engineering & Trading Co. | (6) 465 96 72 | | |
| | P.O. Box 830414 | | | |
| | Amman, 11183 | | | |
| Kazakhstan | ROHDE & SCHWARZ Kazakhstan | 32 72 63 55 55 | | |
| | Liaison Office Almaty | 32 72 63 46 33 | | |
| | Pl. Respubliki 15 | - | | |
| | 480013 Almaty | | | |
| Kenya | Excel Enterprises Limited | (2) 55 80 88 | | |
| | Dunga Road | (2) 54 46 79 | | |
| | P.O. Box 42 788 | | | |
| | Nairobi | | | |
| Korea | Hana Technica Corp. | (2) 514 45 46 | | |
| | Seoul Kangnam, P.O. Box 1458 | (2) 514 45 49 | | |
| | Young Dong Bldg. 4F | hanateco@unitel.co.kr | | |
| | 63-16 Nonhyun-Dong, Kang Nam-Ku | | | |
| | Seoul | | | |
| Kuwait | Group Five Trading & Contracting Co. | 244 91 72 | | |
| | P.O. Box 26645 | 244 95 28 | | |
| | Safat 13127 | | | |
| | State of Kuwait | | | |
| Latvia | Rohde & Schwarz Danmark A/S | (7) 50 23 55 | | |
| | Latvian Branch Office | (7) 50 23 60 | | |
| | Merkela iela 21-301 | rsdk@rsdk.rohde-schwarz.com | | |
| | 1050 Riga | | | |
| Lebanon | Rohde & Schwarz International | (1) 465 64 28 Ext. 303 | | |
| | Liaison Office Riyadh | (1) 465 64 28 Ext. 229 | | |
| | PO Box 361 | | | |
| | c/o Haji Abdullah Alireza & Co. | | | |
| | Riyadh 11411 - KSA | | | |
| Liechtenstein | siehe/see Switzerland | | | |
| Lithuania | Rohde & Schwarz Danmark A/S | 222 46 62 | | |
| | Lithuanian Office | 222 46 62 | | |
| | Lukiskiu 5-228 | | | |
| | 2600 Vilnius | | | |
| Luxembourg | siehe/see Belgium | | | |
| Malaysia | DAGANG TEKNIK SDN. BHD. | (3) 7035503/7035568 | | |
| | No. 9, Jalan SS 4D/2 | (3) 7 03 34 39 | | |
| | Taman People's Park | danik@tm.net.my | | |
| | 47301 Petaling Jaya | | | |
| | Selangor Darul Ehsan | | | |
| Malta | ITEC - International Technology Ltd. | 37 43 00 | | |
| | B'Kara Road | 37 43 53 | | |
| | San Gwann | itec@keyworld.net | | |
| Mexico | Vertrieb Kommunikationstechnik/ Sales of Communications Equipment: | | | |
| | ELECTROINGENIERIA de Precisión | (5) 559 76 77 | | |
| | S.A. (EPSA) | (5) 575 33 81 | | |
| | Uxmal 520 | epsa@compuserve.com | | |
| | Colonia Vertiz Narvarte | | | |
| | 03600 Mexico DF | | | |
| | Vertrieb Messtechnik/Sales of T&M Equipment: | | | |
| | Tektronix S.A. de C.V. | (5) 666 63 33 | | |
| | Periférico Sur 5000, 8° Piso | (5) 666 63 36 | | |
| | Col. Insurgentes Cuicuilco | | | |
| | Del. Coyoacán | | | |
| | 04530 Mexico, D.F. | | | |
| Nepal | Abishek Trade Links (P) Ltd. | (1) 25 69 30 | | |
| | P.O.B. 9700 | (1) 24 25 73 | | |
| | Kathmandu | Durbar@hotel.mos.com.np | | |
| Netherlands | ROHDE & SCHWARZ | (30) 600 17 00 | | |
| | NEDERLAND B.V. | (30) 600 17 99 | | |
| | Perkinsbaan 1 | Rob.DenHartog@rsn.rohde-schwarz.com | | |
| | 3439 ND Nieuwegein | | | |
| New Zealand | Nichecom | (4) 232 32 33 | | |
| | Level 1 Tawa Plaza | (4) 232 32 30 | | |
| | 210 Main Rd / P.O.B. 56-045 | ISDN (4) 237 30 10 | | |
| | Tawa, Wellington | robin.hodgson@nichecom.co.nz | | |
| Nicaragua | siehe/see Mexico (EPSA) | | | |
| Nigeria | Ferrostaal (Nigeria) Ltd. | (1) 262 00 60 | | |
| | 27/29 Adeyemo Alkaija Street | (1) 262 00 64 | | |
| | P.O. Box 72021 | | | |
| | Victoria Island | | | |
| | Lagos | | | |
| Norway | ROHDE & SCHWARZ NORGE | 23 17 22 50 | | |
| | Østensjøveien 36, P.O.B. 103 BRYN | 23 17 22 69 | | |
| | 0611 Oslo | - | | |
| Oman | T&M Equipment and Broadcasting: | | | |
| | Mustafa & Jawad Science & Industry Co. Ltd. | 60 20 09 | | |
| | P.O. Box 3340 | 60 70 66 | | |
| | Post Code 112 | | | |
| | Ruwi | | | |
| | Sultanate of Oman | | | |
| Pakistan | TelcoNet Communications & Engineering | (51) 26 30 72 | | |
| | 213/D, Ordnance Road | (51) 26 32 11 | | |
| | Rawalpindi-Pakistan-46000 | inc@meganet.com.pk | | |
| Panama | siehe auch/see also Mexico (EPSA) | | | |
| | ELECTRONICO BALBOA S.A. | 614 93 64 | | |
| | Av. El Paical, Edif. El Dorado | 236 18 20 | | |
| | Urb. Los Angeles | pdubois@ebsa.com | | |
| | Panama City | | | |
| Papua- New Guinea | siehe/see Australia | | | |
| Peru | siehe auch/see also Argentina | | | |
| | BMP INGENIEROS S.A. | (1) 225 40 30 | | |
| | Av. José Gálvez Barrenechea 645 | (1) 475 15 13 | | |
| | Urb. Corpac - San Borja | wmelgarejo@bmp.com.pe | | |
| | Lima 41 | | | |

Adressen/Addresses

| | | | |
|---------------------------|--|--|---|
| Philippines | MARCOM Industrial Equipment, Inc. MCC P.O.Box 2307 6-L Mezzanine Suite, Vernida I Condominium 120 Amorsolo St. Legaspi Village Makati City/Philippines 3117 | (2) 8 13 29 31 (2) 8 17 05 07 | 12830 Skarpnäck info@rss.rohde-schwarz.com |
| Poland | ROHDE & SCHWARZ Oddzial w Polsce ul. Stawki 2, Pietra 28 00-193 Warszawa | (22) 860 64 90 (22) 860 64 99 rohdepl@rsoe.com | Switzerland Roschi Rohde & Schwarz AG Papiermühlestrasse 145, Postfach 3063 Ittigen - |
| Portugal | TELERUS Sistemas de Telecomunicações, S.A. Rua General Ferreira Martins, Lote 6,2.ºB 1495 Algés | (21) 412 35 90 (21) 412 36 00 telerus@mail.telepac.pt | Syria Electro Scientific Office Baghdad Street Dawara Clinical Lab. Building P.O.B. 8162 Damascus |
| Romania | ROHDE & SCHWARZ Representation Office Bucharest Uranus 98 Bloc U8, scara 2, etaj 5, ap. 36 76102 Bucuresti | (1) 410 68 46 (1) 411 20 13 rohdera@rsoe.com | Tanzania Security Systems (T) Ltd. P.O. Box 7512 Dar Es Salaam |
| Russian Federation | ROHDE & SCHWARZ Representative Office Moscow Kazachy per. 7 109017 Moscow | (095) 234 49 62 (095) 234 49 63 rohderus@rsoe.com | Taiwan Lancer Communication Co., LTD. 16F, No. 30, Pei-Ping East Road Taipei rosa.ho@lancercomm.com.tw |
| Saudi Arabia | Rohde & Schwarz Liaison Office c/o Haji Abdullah Alireza Co. Ltd. P.O.B. 361 Riyadh 11411 | (1) 465 64 28 (1) 465 07 82 - | Thailand Vertrieb Kommunikationstechnik/Sales Communications Equipment: TPP Operation Co., Ltd. 41/5 MoobanTarinee Boromrajchonnee Rd. Talingchan, Bangkok 10170 - |
| Singapore | Vertrieb/Sales: INFOTEL TECHNOLOGIES LTD. 19 Tai Seng Drive Kinergy Building # 06-00 Singapore 535222 | 287 68 22 284 95 55 general@infotel.com.sg | Vertrieb Messtechnik/Sales T & M Equipment: Schmidt Scientific (Thailand) Ltd. 212 Government Housing Bank Bldg. Tower II, 19th Floor, Rama 9 Rd., Huaykwang, Bangkok, Bangkok 10320 - |
| | Service: Rohde & Schwarz Support Centre Asia Pte. Ltd. 1 Kaki Bukit View #04-05/07 Techview Singapore 415941 | 846 37 10 846 00 29 rssca@mbox4.singnet.com.sg | Turkey ROHDE & SCHWARZ Liaison Office Istanbul Bagdad Cad. 191/3, Ard. 81030 Selamicesme-Istanbul |
| Slovak Republic | Specialne systémy a software, a.s. Svrčic ul 84104 Bratislava | (7) 65 42 25 29 (7) 65 42 07 68 3s@internet.sk | Ukraine ROHDE & SCHWARZ Representative Office Kiev ul. Patrisa Loumoumba, 4 252042 Kiev |
| Slovenia | ROHDE & SCHWARZ Representation Ljubljana Koprska 92 1000 Ljubljana | (61) 123 46 51 (61) 123 46 11 rohdesi@rsoe.com | United Arab Emirates Service-Center für den Mittleren Osten/ Service Center for the Middle East: ROHDE & SCHWARZ Emirates L.L.C. P.O.B. 31156 Abu Dhabi - |
| South Africa | Protea Data Systems (Pty) Ltd Communications & Measurement Division Private Bag X19 Bramley 2018 | (11) 786 36 47 (11) 786 58 91 Colin.Forbes@protea.co.za | ROHDE & SCHWARZ Liaison Office Middle East P.O. Box 311 56 Abu Dhabi - |
| Spain | ROHDE & SCHWARZ ESPAÑA Salcedo, 11 28034 Madrid | (91) 334 10 70 (91) 729 05 06 rema@rsd.rohde-schwarz.com | Vertrieb/Sales: ROHDE & SCHWARZ Liaison Office Dubai P.O.B. 53726 Dubai - |
| Sri Lanka | LANKA AVIONICS 658/1/1, Negombo Road Mattumagala Ragama | (1) 95 66 78 (1) 95 83 11 - | R&S BICK Mobile Communication P.O.B. 17466 JAFZ, LOB 04-028 Dubai - |
| Sudan | SolarMan Co. Ltd. P.O. Box 11 545 Karthoum | (11) 47 31 08 (11) 78 17 25 | United Kingdom ROHDE & SCHWARZ UK Ltd. Ancells Business Park Fleet, Hampshire GU 13 8UZ - |
| Sweden | ROHDE & SCHWARZ SVERIGE AB Flygfältsgatan 15 | (8) 605 19 00 (8) 605 19 80 | Uruguay siehe auch/see also Argentina |

Adressen/Addresses

AEROMARINE S.A. (2) 400 39 62
Cerro Largo 1497 (2) 401 85 97
11200 Montevideo aeromar@adinet.com.uy

USA Kommunikationstechnik/Communications Equipment:
ROHDE & SCHWARZ, Inc. (301) 459 88 00
4425 Nicole Drive (301) 459 28 10
Lanham, MD 20706 -

Messtechnik/T & M Equipment:
TEKTRONIX Inc. (800) 835 9433 Ext. 6630
P.O.B. 500, M/S 50-216 (800) 835 7732
Beaverton, OR 97076 -

Venezuela EQUILAB TELECOM C.A. (2) 34 46 26
Centro Seguros La Paz (2) 239 52 05
Piso 6, Local E-61 r_ramire@equilabletelecom.com.ve
Ava. Francisco de Miranda
Boleita, Caracas 1070

Military customers only:
REPRESENTACIONES BOPIC S.A. (2) 985 21 29
Av. Diego Cisneros (2) 985 39 94
Centro Empresarial Los Ruices incotr@cantv.net
Of. 119, 1er piso
Los Ruices
Caracas

Vietnam Schmidt Vietnam Co., Ltd. (4) 834 61 86
8/F, Schmidt Tower, Hanoi (4) 834 61 88
Intern. Technology Centre svnhn@schmidt group.com
Cau Giay, Tu Liem, IPO Box 89
Hanoi

Yugoslavia see/siehe Austria

Nicht aufgeführte Länder/Countries not listed:
ROHDE & SCHWARZ INTERNATIONAL GmbH
P.O.B. 80 14 69
81614 München / Germany
Please fax to +49 89 41 29 136 62



ROHDE & SCHWARZ

Test and
Measurement Division

Basic Instrument and Options

Printed in the Federal
Republic of Germany

Contents

| | Page |
|------------|--|
| 1 | Data Sheet |
| 2 | Operation 2.1 |
| 2.1 | Explanation of Front and Rear Views 2.1 |
| 2.1.1 | Front Panel 2.1 |
| 2.1.2 | Rear Panel 2.4 |
| 2.2 | Preparation for Use 2.5 |
| 2.2.1 | AC Power Mode 2.5 |
| 2.2.2 | Battery Mode 2.5 |
| 2.3 | Operation 2.6 |
| 2.3.1 | Power-Up Status 2.6 |
| 2.3.2 | Controls 2.6 |
| 2.3.2.1 | Softkeys 2.6 |
| 2.3.2.2 | Hardkeys 2.6 |
| 2.3.2.2.1 | Function-based Hardkeys 2.6 |
| 2.3.2.2.2 | Mode-related Hardkeys 2.9 |
| 2.3.2.2.3 | Independent Hardkeys 2.9 |
| 2.3.2.3 | VAR Spinwheel 2.10 |
| 2.3.2.4 | Display 2.11 |
| 2.3.3 | Menu Structure 2.12 |
| 2.3.4 | Error Reaction 2.13 |
| 2.3.5 | Connection of Device under Test (DUT) 2.13 |
| 2.3.6 | Selection Menu 2.13 |
| 2.4 | Transmitter Test (TX-Test) 2.14 |
| 2.4.1 | RF Measurement 2.14 |
| 2.4.2 | Power Measurement 2.17 |
| 2.4.3 | Demodulation 2.20 |
| 2.4.4 | AF Measurement 2.22 |
| 2.4.5 | Filter Selection 2.24 |
| 2.4.6 | Distortion and S/N Measurements 2.26 |
| 2.4.7 | Input Switchover 2.28 |
| 2.4.8 | Lock 2.29 |
| 2.4.9 | Modulation Generators 2.29 |
| 2.4.10 | Oscilloscope / DC Measurement 2.30 |

| | Page |
|------------|---|
| 2.4.11 | Settling Option 2.31 |
| 2.4.11.1 | Description of Controls and Display Elements 2.31 |
| 2.4.11.2 | Power Measurement 2.32 |
| 2.4.11.3 | Frequency Measurement 2.33 |
| 2.4.11.4 | Combined Power and Frequency Measurement 2.33 |
| | |
| 2.5 | Receiver Test (RX-Test) 2.35 |
| 2.5.1 | RF Frequency Setting 2.35 |
| 2.5.2 | RF Level Setting 2.35.1 |
| 2.5.3 | AF Level Measurement 2.37 |
| 2.5.4 | Code, Count 2.39 |
| 2.5.5 | Filter Selection 2.42 |
| 2.5.6 | SINAD and Distortion Measurements 2.42 |
| 2.5.7 | S/N Measurement 2.43 |
| 2.5.8 | Lock 2.44 |
| 2.5.9 | Modulation Generators 2.45 |
| 2.5.10 | Oscilloscope / DC Measurement 2.46 |
| | |
| 2.6 | Duplex Test (DX-Test) 2.47 |
| 2.6.1 | RF Frequency Setting 2.47 |
| 2.6.2 | RF Level Setting 2.47 |
| 2.6.3 | AF Level Setting 2.47 |
| 2.6.4 | Modulation 2.48 |
| 2.6.5 | Filter Selection 2.48 |
| 2.6.6 | SINAD and Distortion Measurements 2.49 |
| 2.6.7 | S/N Measurement 2.50 |
| 2.6.8 | RF Count Measurement 2.51 |
| 2.6.9 | Power Measurement 2.52 |
| 2.6.10 | Demodulation 2.52 |
| 2.6.11 | Modulation Generators 2.53 |
| 2.6.12 | IF Filter 2.53 |
| 2.6.13 | Input Switchover 2.53 |

| | Page |
|------------|---|
| 2.7 | SSB Transmitter Test (TX-SSB) 2.54 |
| 2.7.1 | RF Count Measurement 2.54 |
| 2.7.2 | Power Measurement 2.56 |
| 2.7.3 | Mode Function 2.56 |
| 2.7.4 | AF Measurement 2.56 |
| 2.7.5 | Filter Selection 2.57 |
| 2.7.6 | Distortion Measurement 2.58 |
| 2.7.7 | Input Switchover 2.58 |
| 2.7.8 | Lock 2.58 |
| 2.7.9 | Modulation Generators 2.58 |
| 2.7.10 | Oscilloscope/Settling Measurement 2.58 |
| 2.8 | SSB Receiver Test (RX-SSB) 2.59 |
| 2.8.1 | RF Frequency Setting 2.60 |
| 2.8.2 | Mode Function 2.60 |
| 2.8.3 | AF Level Measurement 2.60 |
| 2.8.4 | AF Count Measurement 2.61 |
| 2.8.5 | Filter Selection 2.61 |
| 2.8.6 | SINAD and Distortion Measurements 2.61 |
| 2.8.7 | Code 2.61 |
| 2.8.8 | Lock 2.61 |
| 2.8.9 | Modulation Generators 2.61 |
| 2.8.10 | Oscilloscope/DC Measurement 2.62 |
| 2.9 | RF Spectrum Analyzer 2.63 |
| 2.9.1 | Attenuation Setting 2.63 |
| 2.9.2 | Resolution Filter Selection 2.64 |
| 2.9.3 | Function Tracking Mode (only if fitted with CMS-B9/-B59) 2.64 |
| 2.9.4 | RF Level and RF Offset 2.64 |
| 2.9.5 | Detection of Short-Circuits and Open-Circuits 2.65 |
| 2.9.6 | Test Input Selection 2.67 |
| 2.9.7 | RF Range Setting 2.67 |
| 2.9.8 | Reference Level Setting 2.67 |
| 2.9.9 | Amplitude Resolution 2.68 |
| 2.9.10 | Sweep Rate 2.68 |
| 2.9.11 | Freeze Function 2.68 |

| | Page |
|-------------|---|
| 2.10 | Definition Menu for Tones 2.69 |
| 2.10.1 | Selection of Standard 2.69 |
| 2.10.2 | Tone Duration 2.70 |
| 2.10.3 | Pause 2.71 |
| 2.10.4 | Frequency Definition 2.71 |
| 2.10.5 | Coupling of Standards 2.71 |
| 2.10.6 | Decoding Time 2.71 |
| | |
| 2.11 | Special Signalling 2.72 |
| 2.11.1 | ATIS 2.72 |
| 2.11.2 | CDCSS 2.72 |
| | |
| 2.12 | Definition Menu for Special Functions 2.74 |
| 2.12.1 | Search Routines 2.74 |
| 2.12.2 | Display Illumination 2.75 |
| 2.12.3 | Relay and TTL Interface 2.75 |
| 2.12.4 | ZOOM 2.79 |
| 2.12.5 | LO Frequency LO/HIGH 2.79 |
| 2.12.6 | IEC/IEEE Bus 2.79 |
| 2.12.7 | SERIAL 2.79 |
| 2.12.8 | Selection of Printer 2.79 |
| 2.12.9 | 600-Ω AF Transformers 2.79 |
| 2.12.10 | AF Voltmeter (Reference Resistance) 2.79 |
| 2.12.11 | External Reference Frequency 2.79 |
| 2.12.12 | Acoustic Acknowledgement 2.80 |
| 2.12.13 | Warnings 2.80 |
| 2.12.14 | Master Reset 2.80 |

| | Page |
|-------------|---|
| 2.13 | Remote Control 2.81 |
| 2.13.1 | Setting the Device Address 2.82 |
| 2.13.2 | Local/Remote Switchover 2.82 |
| 2.13.3 | Interface Messages 2.83 |
| 2.13.3.1 | Universal Commands 2.83 |
| 2.13.3.2 | Addressed Commands 2.83 |
| 2.13.4 | Device Messages 2.85 |
| 2.13.4.1 | Commands Received by the CMS in Listener Mode (Controller to Device Messages) 2.85 |
| 2.13.4.2 | Messages Sent by the CMS in Talker Mode (Device to Controller Messages) 2.88 |
| 2.13.4.3 | Device-independent Commands (Common Commands) 2.90 |
| 2.13.4.4 | Device-specific Commands 2.94 |
| 2.13.5 | Service Request and Status Registers 2.114 |
| 2.13.6 | Resetting of Device Functions 2.118 |
| 2.13.7 | Command Processing Sequence and Synchronization 2.119 |
| 2.13.8 | Error Handling 2.120 |
| | |
| 2.14 | Self-Test 2.121 |
| 2.14.1 | Calibration of Peak Meter 2.121 |
| 2.14.2 | Calibration of RMS Meter 2.121 |
| 2.14.3 | Calibration of Distortion Meter 2.121 |
| 2.14.4 | Power Calibration 2.121 |
| 2.14.5 | Calibration of Modulation Generator 2.121 |
| 2.14.6 | Adjustment of Modulation Generator Filter 2.122 |
| 2.14.7 | Synthesizer Calibration 2.122 |
| 2.14.8 | Battery Check 2.122 |
| 2.14.9 | Cyclic Calibration 2.122 |
| 2.14.10 | Limits of Calibration Values 2.123 |
| 2.14.11 | Error Messages 2.124 |
| | |
| 3 | Maintenance 3.1 |
| 3.1 | Electrical Maintenance 3.1 |
| 3.2 | Mechanical Maintenance 3.1 |
| 3.3 | Storage 3.1 |

Index

A

| | |
|-----------------------------------|------------|
| AC Power Mode..... | 2.5 |
| Active cursor and VAR symbol..... | 2.11 |
| Adjacent Channel Power Meas. | 2.19 |
| AF Level Measurement..... | 2.37 |
| AF Measurement..... | 2.22 |
| AF SCOPE INPUT..... | 2.3 |
| AF Transformers 600-Ω..... | 2.79 |
| AF Voltmeter..... | 2.79 |
| ATIS..... | 2.39, 2.72 |
| Attenuator 24 dB..... | 2.28 |
| Automatic search routine..... | 2.42 |
| Averaging factor..... | 2.21 |

B

| | |
|----------------------------|------|
| Bandwidth measurement..... | 2.36 |
| Battery Mode..... | 2.5 |

C

| | |
|------------------------|------------|
| Cable Fault Test..... | 2.65 |
| CCITT filter..... | 2.25 |
| CDCSS..... | 2.39, 2.72 |
| Channel number..... | 2.17 |
| Channel spacing..... | 2.16 |
| CLEAR, OFF..... | 2.9 |
| Connection of DUT..... | 2.13 |
| CONTRAST..... | 2.3 |

D

| | |
|---|------|
| DC current measurement..... | 2.31 |
| DC voltage measurement..... | 2.31 |
| Decoding Time..... | 2.71 |
| Deemphasis..... | 2.20 |
| Definition menu for Special Functions.... | 2.74 |
| Definition Menu for Tones..... | 2.69 |
| DEMOD OUTPUT..... | 2.3 |
| Demodulation..... | 2.20 |
| Dimension key..... | 2.1 |
| DIRECT COUNT..... | 2.15 |
| Display..... | 2.1 |
| Display Illumination..... | 2.75 |
| Distortion Measurement..... | 2.27 |
| Dual-tone sequences..... | 2.39 |
| DUPLEX SPACE..... | 2.16 |
| Duplex Test..... | 2.47 |

E

| | |
|-----------------------------------|-------|
| EMD-PD switchover..... | 2.37 |
| ENTER, ON..... | 2.8 |
| Error Messages..... | 2.124 |
| External filter..... | 2.25 |
| External Modulation..... | 2.46 |
| External Reference Frequency..... | 2.79 |

F

| | |
|----------------------------|------------|
| Filter Selection..... | 2.24, 2.42 |
| Filters..... | 2.64 |
| Freeze Function..... | 2.68 |
| Frequency Measurement..... | 2.33 |
| FRQ PRESET (IF count)..... | 2.15 |

| | |
|------------------------------------|------|
| FRQ TRANS (transfer function)..... | 2.15 |
| Function Tracking Mode..... | 2.64 |
| Fuse holder..... | 2.4 |

G

| | |
|-------------------------|------|
| Gate time counting..... | 2.24 |
|-------------------------|------|

H

| | |
|---------------------------|------|
| HARDCOPY..... | 2.2 |
| Hardkeys..... | 2.6 |
| Harmonic Measurement..... | 2.19 |

I

| | |
|---------------------------|------|
| IEC-bus commands..... | 2.95 |
| IEC/IEEE-bus address..... | 2.79 |
| IF (IF filter)..... | 2.26 |
| IF and AF filters..... | 2.24 |
| Input Switchover..... | 2.28 |

K

| | |
|------------------------|------|
| KEY BEEP Function..... | 2.80 |
|------------------------|------|

L

| | |
|---------------------------|------|
| Level fine variation..... | 2.36 |
| Listener Mode..... | 2.85 |
| LO Frequency..... | 2.79 |
| Lock..... | 2.29 |

M

| | |
|-----------------------------|------------|
| Master Reset..... | 2.80 |
| MEMORY..... | 2.3 |
| MENU..... | 2.8 |
| Menu Structure..... | 2.12 |
| MOD EXT INPUT..... | 2.3 |
| MOD GEN OUTPUT..... | 2.3 |
| Modulation Generators..... | 2.29, 2.45 |
| Modulation sensitivity..... | 2.20 |

N

| | |
|---------------------------|------|
| NOTCH (Notch filter)..... | 2.26 |
|---------------------------|------|

O

| | |
|-------------------|------|
| Oscilloscope..... | 2.30 |
|-------------------|------|

P

| | |
|-----------------------------|------------|
| Peak Envelope Power..... | 2.17 |
| Peak-value measurement..... | 2.21 |
| Period counting..... | 2.24 |
| Power Measurement..... | 2.17, 2.32 |
| Power-Up Status..... | 2.6 |

Q

| | |
|---------------------------|------|
| Quieting measurement..... | 2.37 |
|---------------------------|------|

R

| | |
|---------------------------|------|
| RANGE..... | 2.6 |
| RECALL..... | 2.10 |
| Receiver Sensitivity..... | 2.42 |
| Receiver Test..... | 2.35 |
| Rectifier..... | 2.21 |
| REF..... | 2.7 |

| | |
|--------------------------------|------------|
| REF MENU | 2.3 |
| Reference channel | 2.16 |
| Relative counting | 2.14 |
| Relay and TTL Interface | 2.75 |
| Remote Control | 2.81 |
| RESON (Resonance filter) | 2.26 |
| RETURN..... | 2.2 |
| RF Frequency Setting..... | 2.35, 2.47 |
| RF IN 2 | 2.4 |
| RF Level Setting | 2.35.1 |
| RF Measurement..... | 2.14 |
| RF Probe | 2.31 |
| RF Spectrum Analyzer..... | 2.63 |
| RMS measurement..... | 2.21 |

S

| | |
|--|------------|
| S/N Measurement..... | 2.27, 2.43 |
| Search Routines | 2.74 |
| Selection Menu | 2.13 |
| Selection of Printer | 2.79 |
| Selective call..... | 2.39 |
| Selective power measurement | 2.17 |
| Self-Test | 2.121 |
| SET RF Function | 2.16 |
| Settling Option | 2.31 |
| SINAD and Distortion Measurements..... | 2.42 |
| Softkeys | 2.1, 2.6 |
| Squelch measurement..... | 2.37 |
| SSB Receiver Test | 2.59 |
| SSB Transmitter Test | 2.54 |
| Status lines | 2.11 |
| STORE | 2.10 |
| Syntax diagram..... | 2.87, 2.90 |

T

| | |
|-----------------------------|------|
| Talker Mode..... | 2.88 |
| Test Input Selection | 2.67 |
| TOL..... | 2.8 |
| Tone sequence decoder..... | 2.22 |
| Tone sequence standard..... | 2.23 |
| Tone sequences | 2.69 |
| Transmitter Test | 2.14 |
| TTL interface | 2.78 |

V

| | |
|--------------------|----------|
| VAR | 2.2, 2.7 |
| VAR Spinwheel..... | 2.10 |

W

| | |
|----------------|------|
| Warnings | 2.80 |
|----------------|------|

Z

| | |
|-----------|------|
| ZOOM..... | 2.79 |
|-----------|------|



ROHDE & SCHWARZ

Test and Measurement
Division

Supplement to Manual (Basic Instrument)

**Testing of ERMES Receivers
with the
CMS**

This test requires a CMS software \geq V4.95!

1 ERMES Main Menu with Controls

The ERMES main menu can be entered by pressing the ERMES key in the selection menu.

In the ERMES main menu, the CMS simulates an ERMES base station. At the socket RF IN/OUT, an RF signal is generated to which ERMES receivers can synchronize. The user can set various signalling parameters, send messages to the receiver under test and check its reaction. Depending on the type of pager, the message sent is signalled optically, acoustically or by vibration on correct reception.

The ERMES service (**E**uropean **R**adio **M**essage **S**ystem) is a radio paging service which permits to transmit tone sequences, numeric and alphanumeric messages from a base station to the subscribers. The ERMES networks of different European countries are to be combined to a common network.

| ERMES | | CMS - Local | |
|----------------|--|---|----------------|
| SET RF CHANNEL | 169.42500 MHz 0 | | RF MODE |
| RF LEV | 10.00 mV  | 4.687 kHz | FM DEVI |
| AF LEV | | | |
| ZONE | 2 | Tone Num | PAGING TYPE |
| COUNTRY | 28 | Alphanum | |
| OPERAT. | 0 | 0 | TOPE ONLY |
| PAGING AREA | 0 | /0.12 34U56-78/9 | NUMERIC |
| INI ADDR | 234567 | LOCAL ADDRESS: | ALPHA |
| BATCH NO | 0 (A) | 3753072 | NUMERIC |
| TRANS. MESSAGE | | ABC .. THE QUICK .. !\"#\$% .. 123 .. abc .. | MESSAGE NUMBER |
| | | 1 | |

Fig. 1-1: ERMES main menu

The following address and identity codes are defined for the system information contained in the ERMES messages:

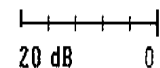
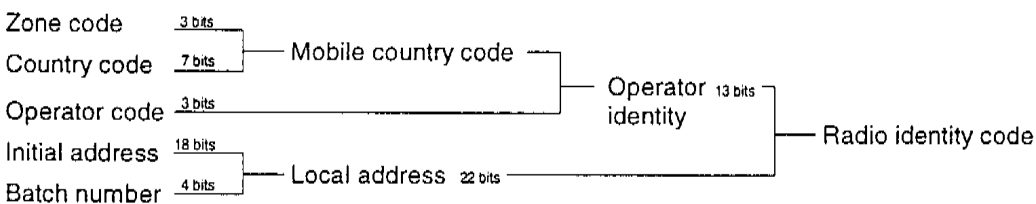

The radio identity code is used by the system on the radio path to identify the receiver(s) for which a paging message is intended. It consists of the mobile country code (10 bits), the operator code (3 bits) and the local address (22 bits).

The mobile country code (3 decimal digits) is defined in Annex A to ETS 300 133-4. The first decimal digit of the mobile country code (zone code) is made up of 3 bits and sent in the supplementary system information. The second and the third decimal digit are made up of 7 bits and sent as country code in the system information word.

3 bits (operator code) are used for encoding up to 8 operators per country. The 22 bits of the local address enable up to 4.2 million ($2^{22} = 4.194.304$) subscribers per operator to be encoded.

After the ERMES main menu has been entered, the CMS starts to issue messages with the ERMES system information. It will take some time for the receiver to synchronize to the signal. If a receiver is taken into operation again for the first time (eg after exchanging the battery), the date and time of day will not be indicated until the receiver is ready for operation. The information on the system time sent as part of the system information can take two forms depending on the channel number set on entering the main menu:

a) Even channel numbers:

The system information (SI) sent contains in the supplementary system information field (SSIF) the value 0000 and thus the parameters
ZONE (for description see softkey ZONE/COUNTRY)
HOUR (the time transmitted is 1 o'clock plus the time elapsed since the ERMES main menu was entered)
DATE (the date transmitted is "13", ie the thirteenth day of a month)

b) Odd channel numbers:

The system information (SI) sent contains in the supplementary system information field (SSIF) the value 0001 and thus the parameters
DAY (the day transmitted is "5", ie Friday)
MON. (the month transmitted is "8", ie August)
YEAR (the year transmitted is "9", ie the year 1999).

ERMES receivers can then synchronize to the ERMES signal sent.

For this purpose, the following parameters must be set:

- The RF frequency must correspond to one of the 16 ERMES channels. According to the ERMES specification, ERMES receivers scan all 16 channels to detect the ERMES signal. The parameter FSI is for this purpose set to a fixed value of 30.
- The RF transmitter level must be set to a sufficiently high value. For radiation, an antenna should be connected to the socket RF IN/OUT.

Set the following signalling parameters according to the receiver data:

- Zone number
- Country code
- Operator number
- Paging area

Before sending a message, the LOCAL ADDRESS must be set to that of the receiver (see INITIAL ADDRESS / BATCH NUMBER function).

The individual parameters will be explained in the following:

Function SET RF / CHANNEL

The function SET RF sets the RF frequency of the CMS. The entry is made using

Softkey SET RF/numerical value/unit or ENTER.

Permissible units are MHz, kHz and Hz.

The ERMES signalling covers the frequency range from 169.425 MHz to 169.800 MHz on 16 channels with a channel spacing of 25 kHz. The data rate is 6250 bits/s.

Table 1-1: Assignment of RF frequencies to ERMES channel numbers

| Frequency [MHz] | Channel number |
|-----------------|----------------|
| 169.425 | 0 |
| 169.450 | 1 |
| 169.475 | 2 |
| 169.500 | 3 |
| 169.525 | 4 |
| 169.550 | 5 |
| 169.575 | 6 |
| 169.600 | 7 |
| 169.625 | 8 |
| 169.650 | 9 |
| 169.675 | 10 |
| 169.700 | 11 |
| 169.725 | 12 |
| 169.750 | 13 |
| 169.775 | 14 |
| 169.800 | 15 |

The ERMES standard defines 16 RF frequencies for the signal transmission. Table 1-1 shows the assignment of RF frequencies to ERMES channel numbers.

The functions SET RF and CHANNEL are coupled to each other. If the function SET RF is used to set a frequency that corresponds to an ERMES channel number, this channel number will be read out in the display next to the text CHANNEL. If the frequency does not comply with any ERMES channel number, the display indicates ---.

When entering the channel number via the function CHANNEL, the associated RF frequency is always indicated next to the text SET RF.

In addition to direct numerical entries, the rotary knob VAR can also be used to vary the functions SET RF and CHANNEL.

Using the key combination

Sofkey SET RF/VAR/numerical value/unit or ENTER
the increment/decrement for variation with the rotary knob VAR can be set.

The key combination Sofkey SET RF/REF/ENTER defines the current frequency to be the reference-frequency. The frequency indication in the display is then referred to the reference frequency. The key combination SET RF/REF/CLEAR permits to leave this operating mode again.

Using the key combination

Sofkey SET RF/REF/numerical value/unit or ENTER
any frequencies can be defined as the reference frequency.

Function RF LEV / AF LEV

These functions define the output socket of the CMS, where the ERMES signal is output. The respective numbers indicate the level value.

If the function RF LEV is active, the ERMES signal is internally modulated in the CMS upon the RF signal at the socket RF IN/OUT.

The numerical value next to the text RF LEV indicates the RF transmitter level. The function RF LEV is identical with the function of the same name in the receiver test main menu.

The numerical entry is made using
Sofkey RF LEV/numerical value/unit or ENTER.

If the function AF LEV is active, the ERMES signal is output as audio signal at the socket MOD GEN and can be used for external modulation upon an RF signal.

The numerical value indicates the level value in volts. A maximum of 5 volts is possible.

The entry is made using
Sofkey AF LEV/numerical value/unit or ENTER.
Possible units are μ V, mV and V.

The functions RF LEV and AF LEV can be switched on or off using the keys ENTER or CLEAR.

In addition to direct numerical entries, the rotary knob VAR can also be used to vary the functions RF LEV and AF LEV.

As in the case of the function SET RF, the increment/decrement for the rotary knob can also be set using the VAR key in the case of AF LEV, and settings can be defined as reference values using the REF key.

Function ZONE/COUNTRY

The ZONE function is used to set the zone number of the receiver. The ERMES standard defines 8 different zones.

Table 1-2: Definition of zone numbers in ERMES standard.

| Zone | Zone number |
|---------------------------|-------------|
| not used | 0 |
| not used | 1 |
| Europe | 2 |
| North and Central America | 3 |
| Asia | 4 |
| Australia and Oceania | 5 |
| Africa | 6 |
| South America | 7 |

The zone numbers are entered using
Sofkey ZONE/numerical value/ENTER.

The COUNTRY function permits to set the country code of the receiver. Entries from 0 to 99 are possible.

Table 1-3: Definition of some European country codes in the ERMES standard.

| Country | Country code |
|---------------|--------------|
| Greece | 02 |
| Netherlands | 04 |
| Belgium | 06 |
| France | 08 |
| Monaco | 12 |
| Spain | 14 |
| Hungary | 16 |
| Italy | 22 |
| Romania | 26 |
| Switzerland | 28 |
| Austria | 32 |
| Great Britain | 34 |
| Denmark | 38 |
| Sweden | 40 |
| Norway | 42 |
| Finland | 44 |
| Poland | 60 |
| Germany | 62 |
| Gibraltar | 66 |
| Portugal | 68 |
| Luxembourg | 70 |
| Ireland | 72 |
| Iceland | 74 |
| Albania | 76 |
| Malta | 78 |
| Cyprus | 80 |
| Bulgaria | 84 |
| Turkey | 86 |

The country codes of the European countries not listed above as well as those of the non-European countries can be obtained from the ERMES

standard description ETS 300 133-4 of the European Telecommunication Standards Institute (ETSI).

The country code is entered using Softkey COUNTRY/numerical value/ENTER.

Function OPERATOR

This function is used to set the network operator. According to the ERMES standard, there are up to 7 possible different network suppliers for each country. The respective operator number of the receiver under test is to be set as numerical value. The entry is made using Softkey OPERATOR/numerical value/ENTER.

Function PAGING AREA

An ERMES network can be divided into up to 64 paging areas. The paging area of the receiver under test is to be set as numerical value using this function.

The entry is made using Softkey PAGING AREA/numerical value/ENTER.

Function INI ADDR/BATCH NO

This function indicates the individual address (call number) of the receiver. The ERMES standard defines 22 bits for the LOCAL ADDRESS in the system information. This corresponds to 4.193.304 subscribers per network operator.

The LOCAL ADDRESS consists of the Initial Address and the Batch Number.

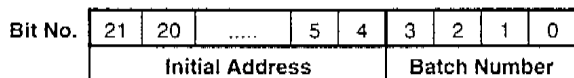

Fig.1-2: Arrangement of Initial Address and Batch Number in the LOCAL ADDR.

The call number is entered by means of Softkey INITIAL ADDRESS/numerical value/ENTER and Softkey BATCH NUMBER/numerical value/ENTER.

The entry and the readout in the display are in the decimal format.

To set the batch number, the last hexadecimal digit of the LOCAL ADDRESS is therefore varied. Following ETS 300 133-4, the batch number is additionally given in the form of a letter (A to P) indicated in brackets.

Function TRANS MESSAGE

This function is used to transmit a message from the CMS. The type of message is selected using the function PAGING TYPE.

After pressing the key, it is displayed on black background. After the message has been issued, the key automatically changes to white again.

The time elapsing until the message is sent depends on how far the ERMES signalling has proceeded at the time of the keystroke. The following scheme explains this relationship:

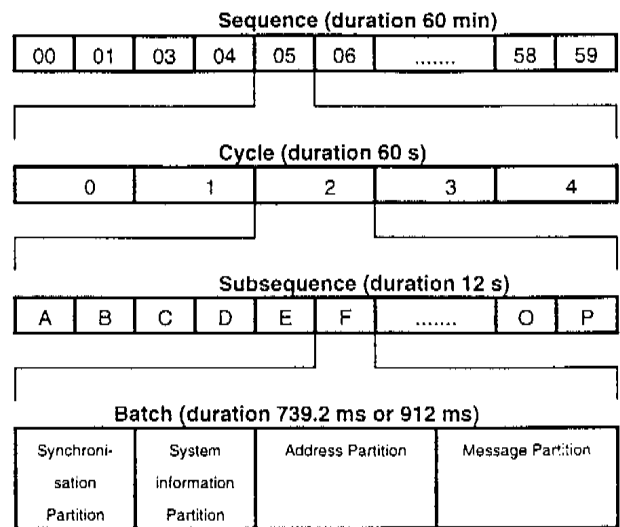

Fig. 1-3: Structure of ERMES transmission protocol for channel 0

16 batches (A to P) are combined to form a subsequence. 15 of the 16 batches take 739.2 ms, and one of the 16 batches 912 ms. The latter may be one of batches A to P, depending on the channel selected. If channel 0 is selected (see Fig. above), batch P takes 912 ms. A subsequence thus has a duration of 12 seconds. 5 subsequences form a cycle, and 60 cycles constitute a sequence with a duration of one hour.

Synchronization Partition:

Is used to synchronize the receiver to the received ERMES signal.

System Information Partition:

Contains information such as zone, country and operator number, paging area, current sequence, cycle, subsequence and batch number and system time.

Address Partition:

Contains the call number (LOCAL ADDRESS) of the receiver for whom the message in the Message Partition is intended.

Message Partition:

Contains the actual information of the message for the user. It remains unused if paging type 0 (TONE ONLY) is used.

Every ERMES receiver is assigned a batch number (A to P or 0 to 15) which cannot be varied by the user and which results from the 4 least significant bits of the LOCAL ADDRESS.

ERMES receivers only respond to messages featuring their own batch number.

Fig. 1-3 shows that it may take up to 12 seconds until a message with a particular batch number can be sent.

To facilitate operation, the function MESSAGE NUMBER is automatically incremented after the message has been sent.

Function AF MODE

This function permits to open a submenu containing the measuring functions AF voltmeter, DC voltage measurement (only with built-in Option CMS-B20) and the oscilloscope.

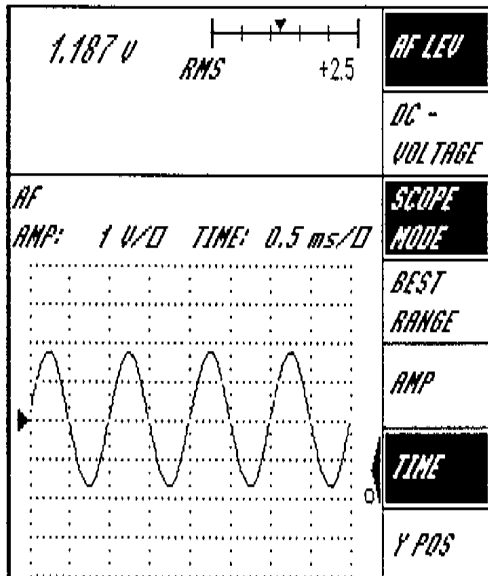

Fig. 1-4: AF submenu

The oscilloscope is operated as in the operating mode transmitter or receiver test. However, the submenu of the function SCOPE MODE cannot be selected.

The input socket AF/SCOPE is set as signal source of the oscilloscope.

If the function SCOPE MODE is active, the CLEAR key permits to stop recording of the signal. The text FREEZE is then indicated in the display. The ENTER key permits to continue the recording again.

Function FM DEVIATION

This function is used to set the FM deviation with which the ERMES signal is modulated upon the RF carrier signal.

The ERMES standard defines a standard deviation of 4.687 kHz.

The numerical entry is made using Softkey FM DEVIATION/num. value/unit or ENTER. Permissible units are kHz and Hz.

In addition to direct numerical entries, the rotary knob VAR can also be used to vary the function FM DEVIATION.

As in the case of the function SET RF, the increment/decrement for the rotary knob can also be set using the VAR key, and settings can be defined as reference values using the REF key.

The function is only effective if the function RF LEV is also active, since only then is the ERMES signal modulated upon the RF carrier and output at the socket RF IN/OUT.

Function PAGING TYPE

This function selects the type of message to be sent.

The ERMES standard defines 3 different types of messages which are also referred to as paging types:

TONE ONLY (paging type 0):

This is a tone-only message that releases a particular receiver-dependent tone sequence in the receiver. Eight different tones are possible at two priority levels.

With this type of message, the Message Partition is not used. The message information is encoded with 4 bits in the Address Partition.

NUMERIC (paging type 1):

With this type of message, up to 20 digits and certain special characters can be transmitted. They are shown in the display of the receiver and may represent a telephone number, for example.

ALPHANUMERIC (paging type 2):

Alphanumeric messages with up to 400 characters and special characters can be transmitted. Receivers of paging type 2 can also receive messages of the two other paging types.

Function TONE ONLY

This functions is used to determine the tone to be sent. The entry is made using

Softkey TONE ONLY/numerical value/ENTER.

Numerical values from 0 to 15 are possible.

The function is only effective if the function PAGING TYPE is set to TONE.

Function NUMERIC

This function is used to determine the numeric message to be sent. The entry is made using

Softkey NUMERIC/string/ ENTER.

The ERMES standard defines the following characters for numeric messages:

Table 1-4: Assignment of the numeric characters to the CMS keys.

| Character | CMS key |
|---------------|-----------------|
| 1 | 1 |
| 2 | 2 |
| 3 | 3 |
| 4 | 4 |
| 5 | 5 |
| 6 | 6 |
| 7 | 7 |
| 8 | 8 |
| 9 | 9 |
| 0 | 0 |
| % | MHz, kHz, %, A |
| / | kHz, μV, W, B |
| U | Hz, dBμV, C |
| Space | dB, dBm, rad, D |
| - (hyphen) | - |
| . (full stop) | . |

The function is only effective if the function PAGING TYPE is set to NUM.

Function ALPHA NUMERIC

This function permits to select one out of 5 predefined alphanumeric messages. The CMS offers the following messages:

- All upper-case letters of the alphabet
ABCDEFGHIJKLMNOPQRSTUVWXYZ
- All lower-case letters of the alphabet
abcdefghijklmnopqrstuvwxyz
- All digits
1234567890
- All special characters defined in the ERMES standard
!@#\$%&'?+,-.=,; :*
- A text containing all letters of the alphabet
*THE QUICK BROWN FOX JUMPS OVER
THE LAZY DOG*

The function is only effective if the function PAGING TYPE is set to ALPHANUM.

Function MESSAGE NUMBER

The messages regarding a particular ERMES receiver can be assigned a continuous number. Thus a receiver is able to determine whether one or several messages have not been received, for example because it has been out of operation for some time.

The numerical entry is made using
Softkey MESSAGE NUMBER /numerical value/ENTER.
Numbers from 1 to 32 are possible.

When pressing the key TRANS. MESSAGE, the function MESSAGE NUMBER is automatically incremented by the CMS.

2 IEC Remote-control Commands

| Command Syntax | Data (number range) | Unit | Description |
|----------------------------|---|------------|--|
| DISPLAY:MENU | 25,00 | --- | Entering the ERMES main menu without submenu |
| DISPLAY:MENU | 25,66 | --- | Entering the ERMES main menu with audio submenu |
| ERMES:RF:CHANNEL | Number (0-15) | --- | ERMES channel number |
| ERMES:AF | Number ON OFF | V Mv Uv | Numerical value for AF level <ul style="list-style-type: none"> Switch on AF level Switch off AF level |
| ERMES:AF:VARIATION | Number | V Mv Uv | Step size of rotary knob for AF level |
| ERMES:AF:REFERENCE | Zahl ON OFF | V Mv Uv | Reference input for AF level <ul style="list-style-type: none"> Switch on reference display Switch off reference display |
| ERMES:ZONE | Number (0 - 7) | --- | Zone number |
| ERMES:COUNTRY | Number (0 - 99) | --- | Country code |
| ERMES:OPERATOR | Number (0 - 7) | --- | Number of network operator |
| ERMES:INIT:ADDRESS | Number (0 - 262143) | --- | Upper 18 bits of call number |
| ERMES:BATCH | Number (0 - 15) | --- | Lower 4 bits of call number |
| ERMES:PAGING:AREA | Number (0 - 63) | --- | Number of paging area |
| ERMES:TRANSMIT | ON | --- | Transmission of ERMES message |
| ERMES:MODULATION | Number ON OFF | MHZ KHZ HZ | Numerical value for modulation deviation <ul style="list-style-type: none"> Switch on modulation Switch off modulation |
| ERMES:MODULATION:VARIATION | Number | MHZ KHZ HZ | Step size of rotary knob for modulation deviation |
| ERMES:MODULATION:REFERENCE | Number ON OFF | MHZ KHZ HZ | Ref. input for mod. deviation <ul style="list-style-type: none"> Switch on reference display Switch off reference display |
| ERMES:PAGING:TYPE | TONE NUM ALPHANUM | --- | Selection of type of message <ul style="list-style-type: none"> Tone-only message Numeric message Alphanumeric message |
| ERMES:TONE | Number (0 to 15) | --- | Tone-only number |
| ERMES:NUMERIC | String (max. length: 20 characters) | --- | Numeric message |
| ERMES:ALPHA:NUMERIC | THE_QUICK CAPITAL SMALL NUMBERS SPECIAL | --- | Selection of alphanum. message <ul style="list-style-type: none"> Text with all letters of the alphabet all upper-case letters all lower-case letters all digits all special characters |
| ERMES:MESSAGE:NUMBER | Number (1-32) | --- | Number of the message to be sent |

The syntax for the functions AF LEV, DC VOLTAGE and the oscilloscope control in the ERMES submenu is identical with that in the transmitter and receiver test and can be obtained from the respective chapter.

2 Operation

The values stated in this section are not guaranteed; only the technical data on the data sheet are binding.

The numbers printed in bold type and italics refer to the controls shown in the front and rear views Figs. 2-1 and 2-2.

2.1 Explanation of Front and Rear Views

2.1.1 Front Panel

(see Fig. 2-1 in appendix)

1

Display

All information for the user is output on the display. It contains a menu heading and status line, describes the functions of the softkeys and indicates the set and measured values in digital and analog form. The information shown on the display changes depending on the selected menu.

2

Softkeys

16 softkeys with alternating functions. The respective function is output on the display directly next to the softkey.

Numbers have been assigned to the softkeys for referencing in the text:

Left-hand
softkey
column

| | |
|--------------------------|---|
| <input type="checkbox"/> | 0 |
| <input type="checkbox"/> | 1 |
| <input type="checkbox"/> | 2 |
| <input type="checkbox"/> | 3 |
| <input type="checkbox"/> | 4 |
| <input type="checkbox"/> | 5 |
| <input type="checkbox"/> | 6 |
| <input type="checkbox"/> | 7 |

Right-hand
softkey
column

| | |
|--------------------------|----|
| <input type="checkbox"/> | 8 |
| <input type="checkbox"/> | 9 |
| <input type="checkbox"/> | 10 |
| <input type="checkbox"/> | 11 |
| <input type="checkbox"/> | 12 |
| <input type="checkbox"/> | 13 |
| <input type="checkbox"/> | 14 |
| <input type="checkbox"/> | 15 |

3

Numeric keypad 0 to 9

For entering values.

4

Dimension key with ENTER function

| | |
|---------------------------------------|-----|
| Frequency | MHz |
| Level | mV |
| Modulation(AM), distortion | % |
| With tone sequences: numeric value | A |

5

Dimension key with ENTER function

| | |
|---------------------------------------|---------|
| Frequency, modulation(FM) | kHz |
| Level | μ V |
| Power | W |
| With tone sequences: numeric value | B |

6

Dimension key with ENTER function

| | |
|---------------------------------------|------------------------|
| Frequency, modulation (FM) | Hz |
| Level | $\text{dB}\mu\text{V}$ |
| With tone sequences: numeric value | C |

7

Dimension key with ENTER function

| | |
|--|--------------|
| Quasi-dimension for relative settings, SINAD, S/N | dB |
| Level, power | dBm |
| Modulation (ϕ M) | rad |
| With tone sequences: numeric value | D |

8**Minus sign**

Every number is positive unless a minus sign is entered.

Input of tone sequences:

| | |
|----------------------|---|
| With DTMF | # |
| With all other codes | F |

9**Decimal point**

Input of tone sequences:

| | |
|----------------------|---|
| with DTMF | * |
| with all other codes | E |

10**ENTER
ON**

- Terminating key for all inputs which do not have or require a dimension or quasi-dimension.
- Switching-on the functions which were switched off by OFF.

11**CLEAR
OFF**

- Abortion of commenced input strings.
- Switching-off of functions
- Switching-off of functions such as REF, RANGE, VAR, TOL.
- Deletion of a deletable message in the 2nd status line.

12**VAR**

Settings can be varied using this spinwheel. The step size and the assignment of the parameter can be defined using the function key VAR.

13**SHIFT**

The keys **14** to **20** have dual functions. The SHIFT key must be pressed to reach the function printed in the top line. The softkeys **0** to **15** also have a dual function depending on the menu. The second function (top or bottom) is made accessible by first pressing the SHIFT key. The status line indicates when the SHIFT function is active.

14**H.COPY *)
START**

H.COPY: Output hardcopy of screen on a printer.

START: Execution of autorun control program (one of the most important functions).

15**RETURN *)
STOP**

STOP: Transfer from IEC bus mode to manual mode.

The following applies in autorun control mode:

RETURN: Transfer from IEC bus mode to manual mode.
Transfer from autorun control mode to manual mode.

STOP: Stop current autorun control program.

16**RECALL
STORE**

RECALL: Recall instrument settings.

STORE: Store instrument settings.

*) depending on model or option

17

**RESET
MENU ↓**

RESET: Set instrument to its factory-setting. Autorun control programs are not cleared in this way.
Menu ↓: Enables searching for submenus together with the active cursor in the display

18

**REF
MENU ↑**

REF: Entered or measured values are declared as reference values.
MENU ↑: Transfer to higher-level menu.

19

**RANGE
VAR**

RANGE: Storing of full-scale value with analog display.
VAR: Definition of setting increment when using VAR spinwheel.

20

**- TOL
+ TOL**

Definition of upper and lower limits. The tolerance markers are set in the analog display, and the tolerance evaluation is defined in the autorun control.

21

CONTRAST

Adjustment of screen contrast.

22

VOLUME

Adjustment of loudspeaker volume.

23

MEMORY

Plug-in for the chip card CMS-Z1 or CMS-Z2.

24

**AF/SCOPE*)
INPUT 
1 MΩ**

Input for all AF and DC measurements. The signals connected here can be evaluated by the AF and DC measurement points or displayed on the scope. Input resistance depends on the model or option.

25

**MOD GEN*)
OUTPUT **

Output of AF generator. Output resistance depends on the model or option.

26

**MOD EXT
INPUT 
1 MΩ**

Input for external modulation signals, also second input for the scope.

27

**DEMOD*) RF*)
OUTPUT  OUT2**

(If RF OUT2 is at the front, DEMOD OUTPUT is provided at the rear).

Output for the demodulated signal.

*) depending on model or option

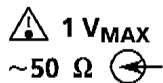
28**RF IN 2**

Second RF input; high sensitivity, therefore suitable for remote measurements.

2.1.2 Rear Panel

(see Fig. 2-2 in appendix)

40**F2: T10.0D/250 V DIN 41571**

Fuse for battery operation.

41

| | | |
|---|---|---|
| L | | B |
| I | O | A |
| N | F | T |
| E | F | T |

This switch has 3 positions:
Line mode ON
Line and battery modes OFF
Battery mode ON

42**11...30 V DC**

Connection of external DC source to instrument.

45**Blower**

The blower and the vents in the instrument housing must not be covered since both the power loss of the instrument and the output power of the radiotelephone are discharged via this blower.

*) depending on model or option

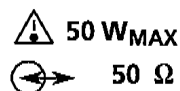
29**RF IN/OUT (optional 80/100 W)**

RF power input, also output for RF signals of instrument. This connector is usually linked to the antenna connector of the radiotelephone.

46**PRINTER PARALLEL INTERFACE *)**

Printer output (Centronics).

47

Alternatively, depending on the model and/or option fitted:

CONTROL

Multifunction input/output with relay connections, TTL inputs / outputs and further functions (Option CMS-B5).

DC MEASUREMENT

Connector for voltage and current measurements.

48

IEC 625 *)
IEC/IEEE bus connection

49

AC supply voltage selector and fuse holder
100/120 V: DIN 41571 - T 1.6 D/250 V
220/240 V: DIN 41662 - T 800/250 V

50**AC power connection**

47 to 420 Hz

2.2 Preparation for Use

Unpack the instrument and check that the listed accessories are present. Before switching on for the first time, refer to Sections 2.2.1 and 2.2.2.

2.2.1 AC Power Mode

Setting the AC Supply Voltage

The instrument is designed for rated AC voltages of 100 V, 120 V, 220 V or 240 V (frequency 47 to 420 Hz). Before switching on the instrument for the first time, check that the correct AC supply is set. With new instruments, the set voltage is printed on the yellow label on the AC connector. If this does not agree with the local voltage, convert as follows:

- Unscrew fuse holder **49** by $1/2$ rotation to the left and remove.
- Remove fuse from fuse holder.
- Set desired voltage (arrow). For this purpose, insert voltage selector switch and rotate.
- Insert fuse with required rating (fuses included in accessories).
A fuse T 1.6 D is required for 100/120 V,
a fuse T800 for 220/240 V.
- Insert fuse holder and lock by $1/2$ rotation to the right.

Once the AC cable has been inserted into the connector **50**, the instrument can be switched on using the rocker switch **41** on the rear panel (LINE position). The instrument is switched off when in the OFF position, even if the AC cable is connected (no standby mode). The power consumption with the basic configuration is approx. 50 VA.

2.2.2 Battery Mode

An external DC supply can be connected to the connector 11 ... 30 V DC **42**. The DC battery socket CMS-Z7 can be purchased using the ordering code 841.1350.02. The connection is made as follows:

(viewed onto soldered side)

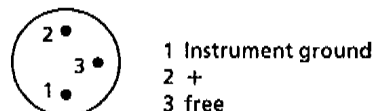

Note:

Connector 42 can only be inserted in one position and thus prevents incorrect polarity. The instrument is not protected against incorrect polarity, however, e.g. when soldering the battery socket.

Spare fuses for battery mode are included in the accessories.

Once the connection to the DC supply has been made, the instrument can be switched on using the rocker switch **41** on the rear panel (BATT position). The instrument is switched off when in the OFF position, even if the battery cable is connected (no standby mode). The power consumption is approx. 40 W.

2.3 Operation

The instrument functions are possible in three main operating modes:

- Manual operation
- Autorun control
- Remote control via IEC/IEEE bus.

2.3.1 Power-Up Status

A selftest including various internal operating point adjustments is carried out following power-up. The selection menu is output in the display if no errors are detected, otherwise the corresponding error message is output (cf. Section 2.14.11).

The instrument is equipped with a back-up battery so that the set parameters and measured values are retained when the instrument is switched off or in the event of a power failure. Only the settings for the selection menu and RF and AF levels do not correspond to the status prior to switch-off. This is for reasons of clarity as well as for the safety of devices-under-test and the instrument itself.

A status independent of the previous settings is achieved using the keys `SHIFT RESET`. Apart from data entered by the user (such as e.g. tone sequence frequencies), this state corresponds to the state when delivered.

If the `RESET` key is actuated and retained during switch-on, all data entered - except for the autorun control programs - are reset (factory-setting).

2.3.2 Controls

The instrument controls comprise the keys and the `VAR` spinwheel **12**.

All instrument outputs with respect to manual operation are on the display **1**.

2.3.2.1 Softkeys

The softkeys have alternate functions. The respective function is output on the display directly next to the softkey. Together with the display, the softkeys are the main elements for menu operation.

Maximally two functions are output on the display next to a softkey depending on the menu.

The function indicated in inverted form (light characters on dark background) is applicable; the other function can be selected using the `SHIFT` key **13** or by pressing again the same softkey.

2.3.2.2 Hardkeys

2.3.2.2.1 Function-based Hardkeys

An active cursor on the display (**▶**) indicates the current function. The hardkeys refer to this function.

Function-based hardkeys:

`RANGE, VAR, REF, -TOL, +TOL, MENU ↓ (DOWN), dimension keys, ENTER, CLEAR`

Examples of hardkey applications:

RANGE

The full-scale value of the analog display usually matches itself to the measured value (auto-ranging). It is sometimes necessary to fix this value during adjustments.

`RANGE/ENTER`

The full-scale value is held at the current value.

`RANGE/CLEAR`

Autoranging becomes active again.

`RANGE/number/ENTER`

The full-scale value is the entered number or next higher number in steps of 1-2-5. The dimension corresponds to that in the display.

`RANGE/number/dimension`

The full-scale value is the entered number or next higher number in steps of 1-2-5 with the selected dimension.

To indicate that the `RANGE HOLD` function is switched on, the full-scale value on the analog display is inverted.

VAR

The VAR spinwheel can be used to vary set parameters. The VAR function is used to define the variation increment and the associated function.

Unless a specific VAR operation is made, the function of the spinwheel always corresponds to the current setting parameter with display of VAR symbol ◦ (see Fig. 2.3-1).

VAR / ENTER

The VAR spinwheel is assigned the selected function; it can only be changed by VAR or VAR ENTER with another function. At the same time, the VAR symbol ◦ is changed to •.

VAR / CLEAR

Cancellation of fixed assignment.

VAR / number / ENTER

Sets a desired variation increment. The dimension corresponds to that in the display.

VAR / number / dimension

Sets a desired variation increment. The dimension corresponds to that in the display.

VAR / 0 / ENTER

Selection of minimum increment.

Exceptions:

- In the case of a frequency setting on the modulation generators 1 and 2, the VAR spinwheel is used to vary frequencies from a fixed series.
- The VAR function is automatically assigned to certain functions (time, amp. and Y pos. on the scope) without the user having to press the VAR key.

The assignment of the VAR function is identified in the display by a symbol.

If a parameter which is assigned the VAR function is switched off using OFF, rotating of the VAR spinwheel has no effect.

REF

The output of measured values or settings on the display can be absolute or referred to a reference value.

Measurements which are always relative values (SINAD, S/N) cannot be referred even further to a reference value. Frequencies are indicated as a frequency difference relative to the reference value. All other relative displays are in dB.

REF / ENTER

The current value is defined as reference value.

REF / number / ENTER

The number is defined to be the reference value. The dimension of the reference value corresponds to that in the display.

REF / number / dimension

The number with the dimension is defined to be the reference value.

REF / CLEAR

Return to absolute dimension.

Identification of relative displays:

The quasi-dimension dB is a relative display. In the case of frequencies, the sign (also +) shows that relative frequencies are displayed.

The analog display has a special feature in the case of relative dimensions or quasi-dimensions:

The 0 point is always on the left.

Either the right-hand half of the axis is shown with a positive full-scale value or the left-hand half of the axis with a negative full-scale value depending on the current measured value. The full-scale value is always displayed on the right, however.

TOL

Entered tolerance values have two effects:

- Limits are entered on the scale of the analog display. They serve for optical orientation during adjustments.
- They enable an evaluation during autorun control depending on the result: tolerance in or tolerance out.

+/- TOL/ENTER

The current measured value becomes the tolerance limit.

+/- TOL/number/ENTER

The entered number is defined to be the tolerance limit. The dimension corresponds to that in the display.

+/- TOL/number/dimension

The entered number with dimension becomes the tolerance limit.

+/- TOL/CLEAR

Deletion of tolerance markers.

Special features:

The two tolerance markers are not always visible.

A tolerance marker is not displayed if it is above the full-scale value. If one tolerance limit is above 0 and the other below 0 in the case of a relative display, not more than one tolerance marker will be visible on the screen because only one of the two branches (either above 0 or below 0) can be displayed depending on the measured value.

Take care with the sign when selecting the tolerance marker if a relative dimension is present:

e.g. -105 dBm is smaller (-TOL) than -95 dBm (+TOL).

MENU ↓ (DOWN)

If the function which the active cursor points to in the display has a submenu, this is indicated in the status line by an arrow pointing downwards. The corresponding submenu is selected by pressing the MENU ↓ key, and a further submenu can be called if present by pressing again. (MENU ↑ (UP): return to status existing before MENU ↓ (DOWN) was entered).

Dimension keys

For settings:

Number/dimension

Setting of value including dimension.

Dimension

Conversion of set value into selected dimension.

With measurements:

Dimension

Representation of measured value in selected dimension.

Entered dimensions are modified by the instrument automatically if the desired dimension is not compatible with the display format.

Exception:

When entering tone sequences, the dimension keys have the significance of digits. The termination function is also cancelled in this context. Tone sequence entries are terminated by the ENTER key.

ENTER, ON

The ENTER key terminates input strings.

These can be commands (REF/ENTER), or also inputs. The ENTER key is used if the dimension is to remain unchanged or if the entered value has no dimension. ENTER can also be used to restore set values previously switched off by CLEAR.

CLEAR, OFF

The 4 functions of CLEAR are:

- Abortion of a commenced input string.
- Switching-off of hardkey functions such as REF, RANGE, VAR or TOL.
- Switching-off of set values; particularly suitable for relative settings with a logarithmic scale since the number "0" has the meaning "Reference value" in this case and not the meaning "Off".
- Deletion of a deletable message in the second status line.

2.3.2.2.2 Mode-related Hardkeys

The instrument can be operated in 6 different modes:

Manual operation mode
IEC/IEEE bus mode (remote *)
Autorun control RUN mode
Autorun control HOLD mode
Autorun control LEARN mode
Autorun control AUTORUN menu

The functions of the hardkeys START, RETURN and STOP correspond to the instrument mode selected.

IEC/IEEE-bus mode (remote *)

STOP
Allows for entering the manual mode providing RWLS (remote with lockout state) was not set. (Meaning : local).

Autorun control: RUN mode

STOP
Results in leaving the RUN mode and entering the HOLD mode.

Autorun control: HOLD mode

START
The autorun control enters the RUN mode and continues the program. (Meaning: continue).

STOP
Change from HOLD mode to manual operation. (final stop)

RETURN
Entering the AUTORUN menu of autorun control.

Autorun control: LEARN mode

START
Start of LEARN mode.

Learn mode commences in the selection menu when it is called for the first time. It commences in the last processed menu if it is called again.

Autorun control: AUTORUN menu

START
Start of selected program (new start in contrast to continue).

2.3.2.2.3 Independent Hardkeys

The hardkeys described here always have the same meaning.

SHIFT
A key pressed upon entering SHIFT selects the second function. This is the function indicated in the top line on the hardkeys. With the softkeys, this is the function with the non-inverted label, which can be output in the display next to the corresponding softkey in the top or bottom line.

CLEAR
Cancels an unintentional input of SHIFT.

RESET
Sets the instrument to a defined initial status. Only user-specific parameters such as the assignment of tone frequencies to digits or programs are retained.

*) depending on model or option

MENU ↑ (UP)

Return to next higher menu. This key has no effect in the selection menu.

STORE

This key has 2 functions:

- In the autorun control (LEARN mode), completely entered commands are stored in autorun control programs. The STORE key has a terminating function in this case.
- In addition, instrument states are transferred to the memory using the STORE key.

Syntax: STORE/number/ENTER

Numbers 1, 2 or 3:

Internal storage of complete instrument settings.

Frequencies for AF1 are stored only if the function AF COUPL (submenu DIST/SINAD, DIST) is off.

Numbers 4 to 9:

Storage of instrument settings on the chip card.

Numbers 20 to 39 (two-digit):

Storage of RF frequencies.

RECALL

The RECALL function corresponds to the STORE function.

- The internally-stored instrument status is set by entering
RECALL/number (single-digit)/ENTER
- The stored frequency is output in the status line by entering
RECALL/number (two-digit)
and can be accepted using ENTER or deleted using CLEAR.

The STORE and RECALL functions can also be integrated in an autorun control program.

Example:

| 10 /MHz | STORE | STORE/3 /ENTER | STORE |
|------------|--|-------------------------------|--|
| Set 10 MHz | Implementation in an autorun control program | Store RF setting in memory 13 | Implementation of storage procedure in the autorun control program |

H.COPY *)

Produce hard copy of current display on a printer.

2.3.2.3 VAR Spinwheel

In contrast to specific entry of parameters using the keys, the VAR spinwheel is used for parameter variation. Its function is very similar to that of the VAR key (see function-based hardkeys (VAR), Section 2.3.2.2.1). The VAR spinwheel can either be specifically assigned to a desired function or can be assigned to the current function. The variation is possible in any step sizes, also logarithmic. The setting values are increased by rotating clockwise and decreased by rotating counterclockwise. The VAR spinwheel is automatically assigned to the scope functions amplitude, time and Y-position.

Special features of VAR spinwheel:

The input VAR/0/ENTER does not lead to the minimum increment in the case of a frequency setting on modulation generators 1 and 2. In this case, frequencies from a fixed series are varied using the spinwheel:

0.3 / 0.6 / 1 / 1.25 / 2.7 / 3 / 6 / 10 kHz
(default settings)

The VAR spinwheel has no effect (even in background mode) if it is used on a set value which has been switched off using OFF.

*) depending on model or option

If RF levels are reduced using the VAR spinwheel, these settings differ from the corresponding direct key entries in the following manner:

The spinwheel variation utilizes the interruption-free, electronic reduction in level as far as possible (-19.9 dB with FM and ϕ M, -4.9 dB with AM), whereas the mechanically switched attenuators are used as far as possible to set the level with a key input.

Entry of level via keys:

Best possible broadband S/N ratio, but interruption in level when changing (audible switching of attenuator set).

Entry of level using the VAR spinwheel:

Interruption-free level variation, e.g. for squelch measurements.

In contrast to all other settings, an analog display is also provided for the RF level setting. This represents the interruption-free level fine variation (when reducing from right to left).

In the case of the two-function softkeys (e.g. COUNT/SET RF), when the VAR spinwheel can only be used for one of the softkey functions, the activated VAR symbol is displayed also if the softkey function without possible VAR operation is selected.

2.3.2.4 Display

The functions of the display are to indicate user inputs, to display setting and measured values in analog and digital form and to describe the respective function of the softkeys.

Status lines

The operating mode of the instrument is described in the top status line. The second status line contains messages.

Softkey inscriptions

The respective function of the softkeys is output at the right-hand and left-hand margins of the display, directly next to the softkeys. The function displayed in inverted form is currently active. If the softkey is assigned two functions, the second function can be activated using the SHIFT key. The active cursor is positioned next to one of these fields (see Fig. 2.3-1). It marks the function which can be manipulated by entering values or by using the function-based hardkeys (see Section 2.3.2.2.1).

The VAR symbol \circ is changed to \bullet if the adjacent parameter has been set for VAR spinwheel variation.

Representation of measured and set values

Measured and set values are output in the centre of the display. Set values are usually displayed in digital form only (exception: RF level setting with VAR spinwheel). Measured values are displayed in digital and analog form. Attributes such as RMS or PK refer to the nature of the measured value. The analog displays may be provided with tolerance markers (see function-based hardkeys (TOL), Section 2.3.2.2.1).

The submenus at the lowest position in the hierarchy usually fill a small section of the display only. These display fields overwritten by the submenu are emphasized by italic lettering.

The display can also copy the oscilloscope or spectrum monitor display in addition to the digital and analog outputs of individual measured values. It is only used as an editing or displaying tool in certain menus.

The display characteristics are described in detail in the individual menus.

If the CMS is not operated on for some time, the display will become dark so as to save energy (which is of particular importance when the CMS is operated from battery). It will be bright again by pressing any key. This keystroke does not have any other function then.

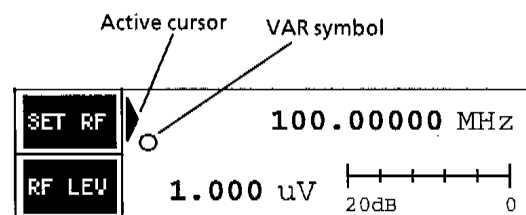
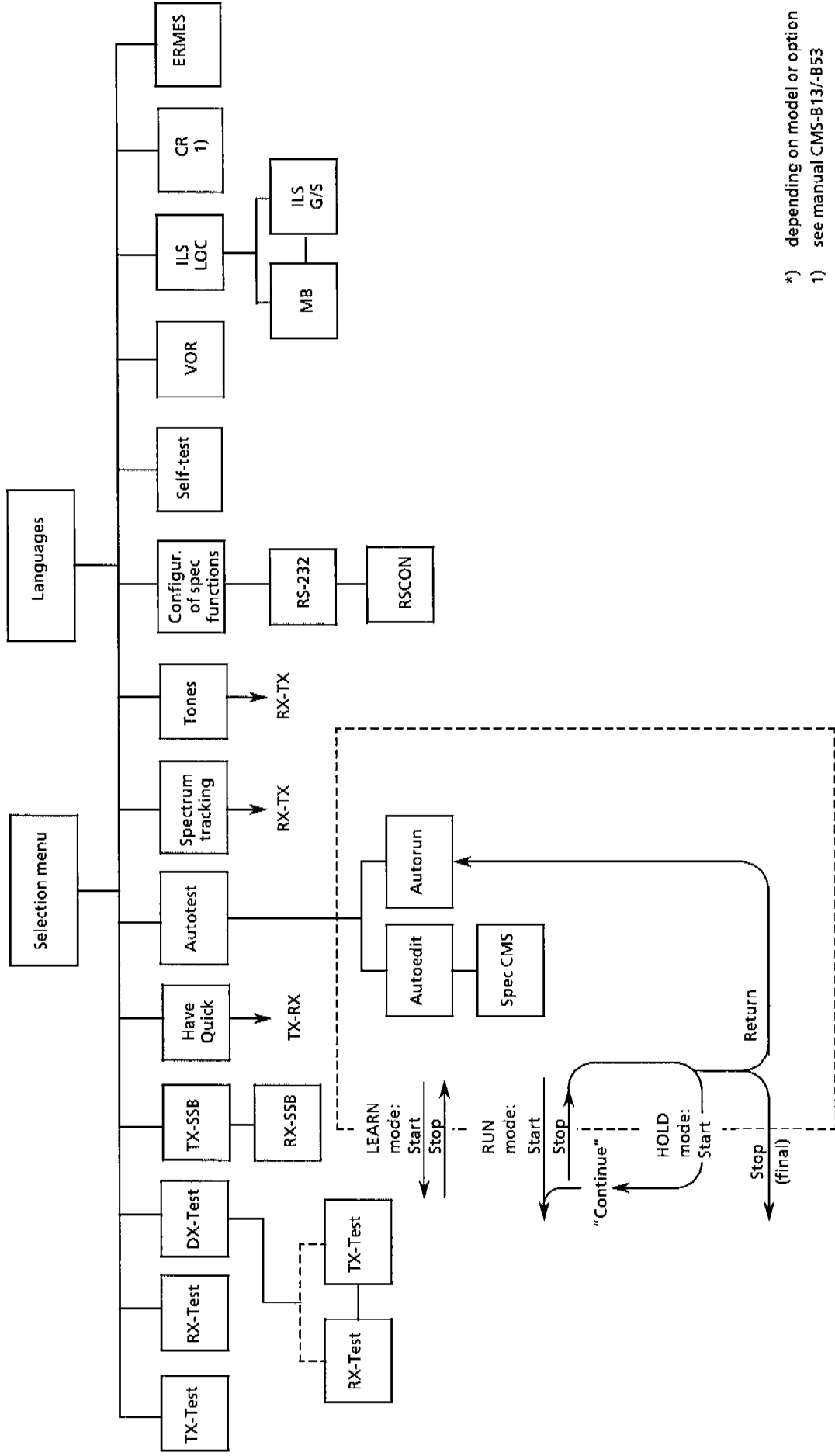

Fig. 2.3-1 Active cursor and VAR symbol

2.3.3 Menu Structure*)

Fig. 2.3-2 illustrates the menu structure of the instrument without consideration of lower hierarchical levels.



*) depending on model or option
 1) see manual CMS-B13/-B53

Fig. 2.3-2 Menu structure

2.3.4 Error Reaction

If erroneous operation occurs, the instrument outputs an error message in the status line and produces an audible signal, and rejects the setting. Range violations beyond the minimum value are replaced by the minimum value. Range violations above the maximum value are rejected in order to protect the connected device-under-test. The instrument also reacts to faulty test routines by display of a message and by an audible signal.

2.3.5 Connection of Device-under-Test (DUT)

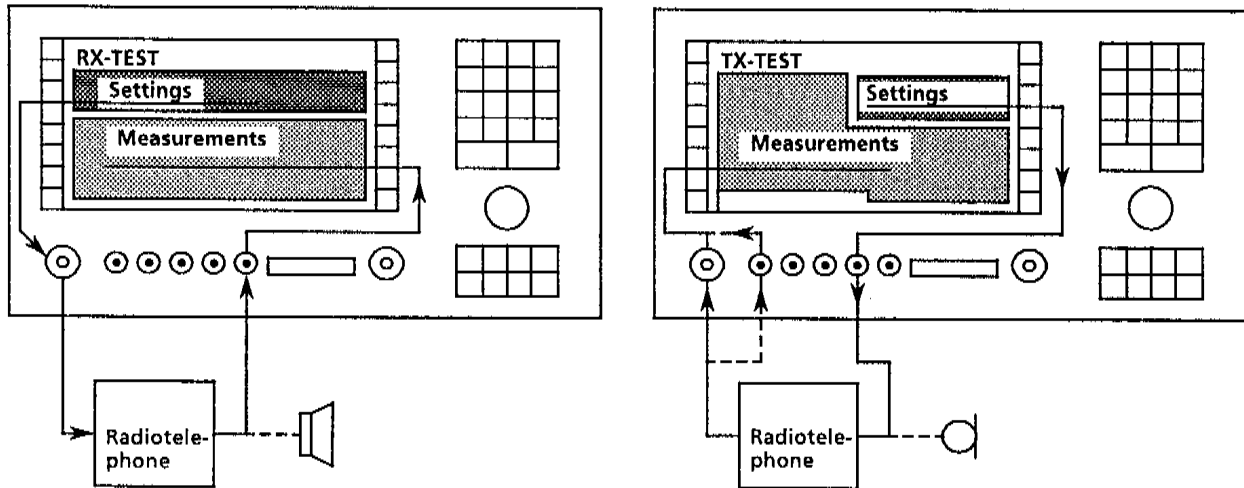

Fig. 2.3-3 Connection of the device-under-test

2.3.6 Selection Menu

After switching on the instrument the selection menu offers all main menus.

| | | | | | |
|---|---------|---|-------------------------|---------|---------|
| 0 | RX-TEST | SELECT | CMS - Local HARDCOPY | TX-TEST | 8 |
| 1 | AUTOTST | RADIOCOMMUNICATION SERVICE MONITOR | | TONES | 9 |
| 2 | DX-TEST | | | CR | 10 |
| 3 | SPECT | | | VOR | 11 |
| 4 | SSB | | | ILS/MB | 12 |
| 5 | | | | ERMES | 13 |
| 6 | NATION | | | GB | 14 |
| 7 | CONFIG | | | | 15 |
| | | | | | SELFCHK |

Fig. 2.3-4 Selection menu

2.4 Transmitter Test (TX-Test)

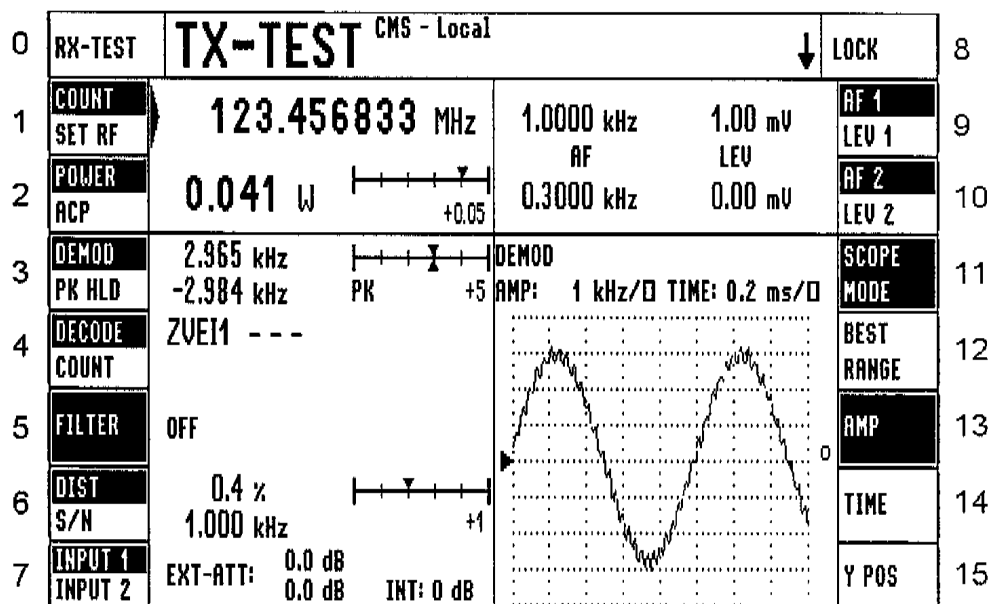

Fig. 2.4-1 Main menu TX-TEST

Starting with the main menus of the selection menu, the main menu TX-TEST (transmitter test) can be entered by pressing the softkey TX-TEST.

This menu contains all controls required to carry out a standard transmitter test. Almost every function contains submenus. These provide controls for more transmitter test functions, which are less often required.

Softkey 0 can be used to directly branch to the main menu for the receiver test (RX-TEST).

2.4.1 RF Measurement

In the case of simple transmitter tests the instrument measures the transmitter frequency and sets the demodulators to this frequency. The receiver frequency of the instrument can also be preset if the device under test outputs several carrier frequencies or if the time for counting is insufficient for the demodulator to respond rapidly (demodulation of a fast acknowledgement).

The counter resolution can be set using the following input sequence: softkey COUNT/number 1 or 10/terminating key Hz OR ENTER. Thus 1 Hz (slow) or 10 Hz (fast) is selected as the counter resolution.

The sensitivity of the RF counter in particular with frequencies < 1 MHz can be enhanced by switching the IF filter on (FILTER submenu 2, softkey 6: IF-NARROW).

COUNT Function

The count function is constantly active if the COUNT field is shown in inverted form.

The normal count function only operates at the connector RF IN/OUT. Depending on the model, the direct RF count also operates at the sensitive input (input 2).

Relative counting

There are two possibilities for selecting a reference frequency for relative counting.

Input of softkey COUNT/REF/ENTER declares the frequency just measured as the reference frequency; input of softkey COUNT /REF /number /termination key dimension OR ENTER declares the entered frequency as the reference frequency.

A sign in front of the result indicates that a relative frequency count is being carried out. Absolute frequency counting can be reselected by entering `softkey COUNT/REF/OFF`.

The dimensions MHz, kHz or Hz can be selected for direct or relative counting, e.g. `softkey COUNT/Hz`.

COUNT Function: Submenu

The function COUNT has a submenu which is output in the display fields next to softkeys 3, 4 and 5.

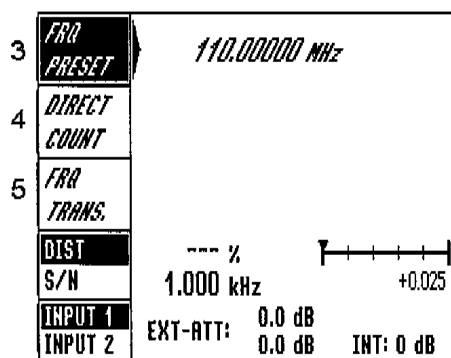

Fig. 2.4-2 COUNT submenu

The normal count function comprises a coarse direct broadband count and a subsequent exact narrowband IF count. The direct count is possible only at the connector RF IN/OUT, the IF count is possible at both inputs (RF IN/OUT and RF IN 2).

Softkey 3: FRQ PRESET (IF count)

A frequency count can be initiated in a narrow-band range (approx. 100 kHz) by entering a frequency.

Switch-on: `Softkey3/number/dimension` or `ENTER`
The entered frequency replaces the coarse count.

Switch-off: `Softkey3/OFF`

Applications:

The IF count method can also be used at the input RF IN 2. If a source outputs several carrier frequencies with a sufficiently large spacing (approx. > 1.5 MHz), this method can be used to select a carrier frequency and to selectively count it. (Method of selection: see softkey 5 (FILTER:IF NARROW) in the main menu).

Note: *If the squelch function of the CMS is deactivated (submenu DEMOD), only a restricted COUNT function is possible:*

- OFF:** no function
- ON:** first apply the RF signal to be measured, then press softkey COUNT.

Softkey 4: DIRECT COUNT

Switch-on: `Softkey 4/number 100 or 1000/dimension Hz or ENTER`. Direct counting is carried out with a resolution of 100 or 1000 Hz, but only via the connector RF IN/OUT.

Switch-off: `Softkey 4/OFF`

Applications:

Measurements can be performed on relay stations even if the instrument is not equipped with a duplex modulation meter. The signal generator of the instrument stimulates the receiver of the relay station, while the direct counter determines the frequency of the relay station transmitter, which may also be in a completely different frequency band.

Softkey 5: FRQ TRANS (transfer function)

Actuating this softkey once transfers the measured frequency as CMS receiver frequency.

In the main menu, this action switches from the COUNT function to the SET function.

Application:

Softkey 5 facilitates operation with regard to the entry of multi-digit and often unknown transmitter frequencies as CMS receiver frequency.

SET RF Function

The receiver frequency of the instrument is fixed using the SET RF function. It is not based on the counter result. If the SET RF function is not already active (displayed in inverted form), it can be activated by entering `SHIFT/softkey SET RF`. The CMS receiver frequency is usually entered and displayed as a frequency value.

The CMS receiver frequency is entered using softkey `SET RF/number/dimension` OR `ENTER`.

The receiver frequency setting can be varied using the VAR function and the VAR spinwheel. The receiver frequency setting can also be relative.

The reference frequency can be entered using softkey `SET RF/REF/ENTER` if the current frequency is to become the reference frequency, or using the softkey `SET RF/REF/number/dimension` OR `ENTER` if a frequency is to be set different from the reference frequency.

SET RF Function: Submenu

The SET RF function has a submenu which is output in the display fields next to softkeys 3 to 7.

| | | | |
|---|---------------------|-----------------------|----------|
| 3 | <i>FRQ TRANS.</i> | | |
| 4 | <i>DUPLEX SPACE</i> | <i>+0.00000 MHz</i> | |
| 5 | <i>REF-CHANNEL</i> | <i>+120.00000 MHz</i> | <i>0</i> |
| 6 | <i>CH-SPACE</i> | <i>+25.00 kHz</i> | |
| 7 | <i>CH-NUMBER</i> | | |

Fig. 2.4-3 SET RF submenu

Softkey 3: FRQ TRANS (frequency transfer function)

Actuating this softkey switches the frequency transfer function on or off.

An activated transfer function has the following effects:

- At the point of switchover from TX→RX, the RX RF frequency is calculated from the RF frequency set or counted in the TX test and the duplex spacing.
- At the point of switchover from RX→TX, the TX RF frequency is calculated from the RF frequency set in the RX test and the duplex spacing, if the RF counter in the TX test is off.
- When the RX RF frequency in the duplex menu is changed, the TX RF frequency continuously follows displaced by the duplex spacing, if the RF counter is off.
- When the TX RF frequency is changed (by RF counter or setting), the RX RF frequency follows displaced by the duplex spacing.

Softkey 4: DUPLEX SPACE

The duplex spacing is entered by sequence `sign/number/(dimension OR ENTER)`.

Values between -500MHz and +500MHz are possible.

The duplex spacing is positively counted if the RX RF frequency is larger than the TX RF frequency.

Softkeys 5, 6 and 7 serve to define the channel numbers.

Softkey 5: REF CHANNEL (reference channel)

The reference channel is entered by `number/ENTER`.

Values between 0 and 9999 are possible.

Entries are permissible only if the channel number mode is off (softkey 7).

This entry establishes reference between frequencies and channel numbers. In addition to the reference channel entry, also the respective reference frequency is displayed.

At a duplex spacing not equal to zero, the reference frequency in the TX and RX test is different. In the DX test, the reference frequency is always referred to the RX frequency.

Softkey 6: CH-SPACE (defining channel spacing)

The channel spacing is entered by sequence `sign/number/(dimension OR ENTER)`.

Values between -1MHz and +1MHz are possible.

Entries are permissible only if the channel number mode is off (softkey 7).

A positive sign means that higher channel numbers correspond to higher frequencies.

Softkey 7: CH NUMB. (channel number)

Actuating softkey 7 switches the channel number mode on or off.

When channel number mode is on, frequencies are only displayed as channel numbers plus offset. Reference between channel numbers and frequencies is made when the reference channel is entered.

If the channel number mode is activated in the RX or DX test, the RX RF frequency is assigned to the reference channel selected by softkey 5. The TX channel number is calculated from the TX RF frequency and the duplex spacing and displayed if present in the menu.

If the channel number mode is activated for the TX test, the TX RF frequency is assigned to the reference channel selected by softkey 5.

With VAR spinwheel variations, also the frequencies are varied in the channel number mode. This gives the offset to the channel number.

Offset also occurs if the RF counter counts frequencies that are not exactly in line with the channel spacing.

Frequencies with channel numbers below 0 or above 9999 are not indicated as channel number plus offset, but by normal frequency display.

2.4.2 Power Measurement

POWER Function

The broadband RF power measurement can only be performed at the RF IN/OUT socket; the selective RF power measurement can also be carried out at the RF IN 2 socket (input 2). The dimensions of the broadband RF power measurement are W or dBm, those of the selective RF power measurement are mV, W, dB μ V or dBm.

A logarithmic relative display based on a reference value can be selected. Tolerance markers can be set on the analog bar for the dimensions mentioned above; Autorange or Range Hold can be selected on the analog display for the full-scale value.

Selective power measurement:

In this measurement mode the CMS is automatically operated in the mode BEAT mode with an IF of 2 kHz (LO frequency of the local oscillator is 2 kHz below the frequency indicated).

The demodulator is switched off. The test bandwidth is approximately the set receiving frequency \pm 50 kHz.

The dynamic range is dependent on the input:

RF IN/OUT: ca. 125 μ V (-65 dBm) to 50 V (47 dBm)
RF IN 2 : ca. 22 μ V (-80 dBm) to 4mV (-35 dBm)

Measurement sensitivity can be increased by reducing the test bandwidth using the filters available in the CMS.

The use of the CCITT filter may cause problems as, in accordance with the definition, it features no constant attenuation characteristic in the pass band.

In contrast to the broadband RF power measurement, the selective RF power measurement also includes the Peak Envelope Power (=PEP). With AM results that are up to 6 dB higher (100%) are therefore obtained. Calibration of the selective RF power measurement is not required.

Note: *Limiting sensitivity may be reduced as a result of strong signals outside the measuring bandwidth. If the frequency of the device-under-test strongly deviates from the nominal frequency, the measurement may be impaired.*

Remedy: *Monitoring the 2-kHz beat signal by way of the loudspeaker or scope.*

POWER Function: Submenu 1

Pertaining to the POWER function a submenu is available, which is assigned to the fields beside the softkeys 3 to 6 in the display.

| | | | |
|---|---------------|----------|------------------|
| 3 | PEP | | |
| 4 | TIME | AUTO | FAST SLOW |
| 5 | POWER HOLD | | |
| 6 | POWER HLD RES | | |
| | INPUT 1 | EXT-ATT: | 0.0 dB |
| | INPUT 2 | | 0.0 dB INT: 0 dB |

Fig. 2.4-4 POWER submenu 1

Softkey 3: PEP

The type of RF power measurement (selective or broadband) is selected using this softkey.

ON: Selective RF power measurement
 OFF: Broadband RF power measurement

Softkey 4: TIME

With broadband RF power measurements a low-pass filter in the measurement path is switched on (SLOW) or off (FAST) using this function. With the setting AUTO the lowpass is switched on during AM modulation; otherwise the lowpass is off. Its cutoff frequency is about 4 Hz.

Softkey 5: POWER HOLD

Storage of the maximum value is switched on when actuating this softkey, i.e. the highest measured value of each RF power measurement (selective or broadband) is stored until deletion. The maximum value is deleted by pressing the softkey 6 (POWER HLD RES) or softkey 2 (POWER).

Softkey 6: POWER HLD RES

The maximum value of RF power measurement currently stored is deleted provided that softkey 5 (POWER HOLD) is activated.

POWER Function: Submenu 2 *)

VSWR - Voltage Standing Wave Ratio. A second submenu with softkeys 3 to 7 assigned is available for this measurement.

VSWR measurement comprises the determination of the forward and reflected power and the calculation of their ratios (VSWR).

VSWR measurement is effected using a measuring head (NAS-Z1, Z3, Z5, Z6, Z7) which is connected at the rear of the CMS via a sub-D cable at the 50-contact connector.

The measuring head, which is inserted between transmitter and antenna, determines the forward and reflected voltage. An analysis of the data supplied by the measuring head is effected in the CMS, with an additional indication of the ratios of the two voltages.

VSWR measurement is executed by opening the 2nd submenu under the <POWER> softkey and by connecting the measuring head. In some models the start in the TX menu is then automatic *).

After the VSWR measurement has started, the values of the forward and reflected voltage as well as the ratio of these two values are indicated one below the other. These values are indicated in digital form with an additional representation on the analog bar.

| | | | |
|---|------------|----------|-----------|
| 2 | POWER FORW | 15.6 dBm | |
| | | | +25 |
| 4 | POWER REFL | 1.7 dBm | |
| | | | +25 |
| 6 | VSWR | 1.505 | |
| | | | +1.0 +3.5 |

Fig. 2.4-5 POWER submenu 2

Functions "TOL" and "REF" cannot be used for the indication of the VSWR value. A change of unit is neither possible in the indication of this value which has no unit. Further, the analog bar scaling of the VSWR result always starts with 1.

*) depending on model or option

The VSWR function (softkey 6) allows the entry of a correction factor for the forward and reflected wave in the range from 1 to 100. The selected correction factor is always linear and matches the CMS with the measuring head used. If the factor is $\neq 1$, ! is displayed in front of the measured value.

ACP Function *)

Adjacent Channel Power Measurement (ACP)

The desired channel and the adjacent channel are measured using the filters described in the specifications (FT 17 TR 2049, ETS 300086) and set in relation to each other.

Measured value (dB) = 10 x log (power of used channel / power of adjacent channel)

The following values are specified for the CMS:

- Channel spacing 25 kHz
- ACP filter bandwidth 16 kHz
- Required spacing 70 dB

Before switching on the adjacent channel power measurement, the desired reference frequency must be entered using the softkey "SET RF". If this frequency is omitted, a warning is displayed in status line 2.

ACP Function : Submenu 1

The ACP function has a submenu which appears in the display adjacent to the softkeys 3 to 6.

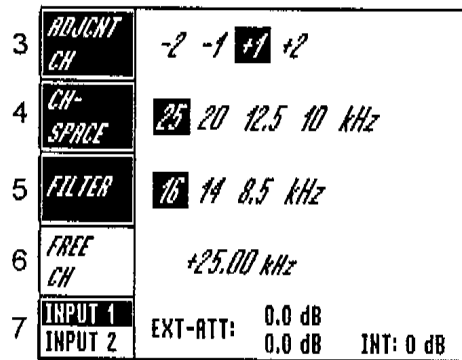

Fig. 2.4-6 ACP submenu 1

Softkey 3: ADJCNT CH
Channel select for the first/second and upper/lower adjacent channel.

*) depending on model or option

Softkey 4: CH SPACE

Selecting specified channel spacing with automatic filter switching.

Softkey 5: FILTER

Filter selection when choosing "free" channel spacing.

Softkey 6: FREE CH

Selecting a user-defined channel spacing up to 1000 kHz in 10-Hz steps.

ACP Function : Submenu 2

Harmonic Measurement (not for CMS 50)

This submenu of the ACP measurement has softkeys 2 to 6 assigned. The harmonic measurement permits to determine the power of the first to fourth harmonic of an RF carrier. The frequency of the nth harmonic is equal to n times the frequency of the RF carrier.

| | | | |
|---|-----------------|-------------------|-----------|
| 1 | COUNT SET RF | 20.00000 MHz | |
| 2 | POWER ACP | CARRIER: 16.6 dBm | |
| 3 | ALL | HARMONICS: | |
| 4 | 1st | 55.4 dB | -----+100 |
| 5 | 2nd | 57.5 dB | -----+100 |
| 6 | 3rd | 72.9 dB | -----+100 |
| 7 | 4th | 41.3 dB | -----+100 |

Fig. 2.4-7 ACP submenu 2

The harmonic measurement is to be found in the second submenu of the ACP measurement. Before entering the harmonic submenu, COUNT must be switched to SET RF and the RF frequency of the carrier to be examined set.

After opening the menu, the measurement is started automatically. The absolute power of the RF carrier is indicated opposite to the ACP key.

There are two possible ways of measuring harmonics:

1. If the key ALL is active, the four harmonics are measured cyclically one after the other.
2. If the key ALL is not active, only the power of the currently selected harmonic is measured.

The power unit of the harmonic is determined by the unit of the fundamental. This can be selected by pressing a unit key if the active cursor is positioned on the ACP key.

The following units are possible for the harmonic measurement:

Table 2.4-1

| Unit of fundamental | Unit of harmonics |
|---------------------|-------------------|
| mV/V | mV/V |
| μ W/mW/W | μ W/mW/W |
| dB μ V | dB μ V |
| dBm | dB |

2.4.3 Demodulation

Softkey 3 is assigned two functions:

DEMOD (continuous demodulation)
PK HLD (demodulation with peak hold function)

The first or second function is selected using the SHIFT key.

DEMOD Function

The instrument is able to demodulate the transmitter signal according to AM, FM or ϕ M. One of the three demodulation modes is selected by the following input:

softkey DEMOD/dimension. FM demodulation is then used for the dimensions Hz and kHz, AM demodulation for % and ϕ M demodulation for rad.

Different weighting modes can be selected in the submenu. If peak weighting is selected, the positive and negative peaks are displayed at the same time. Tolerance markers and decision criteria such as e.g. branching in the autorun control program always refer to the positive peak value, however. The RMS weighting generates only one measured value.

Modulation sensitivity

The modulation sensitivity is integrated in a search routine, which varies the AF voltage of the

modulation generator at the transmitter input until a predefined modulation depth, frequency deviation or phase deviation is attained as transmitter modulation.

The entry is made using:

Softkey DEMOD/number/dimension.

The number corresponds to the entered modulation value and the dimension to the demodulation mode of the CMS.

If the demodulation mode output in the display is to be retained, ENTER can be input instead of the dimension.

The analog display can be assigned a full-scale value depending on the measured value or a fixed full-scale value (see function-based hardkeys (RANGE), Section 2.3.2.2.1). The positive peak value applies if the fixed full-scale value is to be derived from the currently measured value.

Tolerance markers can be entered in the analog display (see function-based hardkeys (TOL), Section 2.3.2.2.1). In the event of two measured values it is again the positive peak value which is used for the tolerance weighting.

DEMOD Function: Submenu

The DEMOD function has a submenu which is output in the fields in the display next to softkeys 4 to 7.

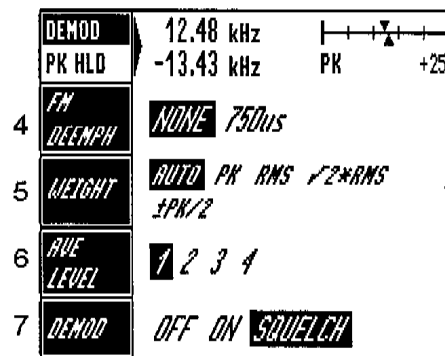

Fig. 2.4-8 DEMOD submenu

Softkey 4: FM DEEMPH (deemphasis)

Softkey 4 can be used to switch on or off a 750- μ s-deemphasis. This function is only of significance with FM selected.

Softkey 5: WEIGHT (rectifier)

Softkey 5 is used to select the detector. There are five different possibilities:

AUTO: Noise signals are RMS weighted and wanted signals are peak weighted. Small signals are automatically considered to be noise signals and large signals to be wanted signals.

The limit (RMS) is
200 Hz frequency deviation for FM
0.2 rad phase deviation for ϕ M
1 % modulation depth for AM.

PK: Simultaneous positive and negative peak-value measurements.

RMS: Real RMS measurement.

$\sqrt{2} * \text{RMS}$: Real RMS measurement multiplied by 1.41.

This measurement is used for determination of the peak value when modulating with sinewave signals, and the integrating effect of the RMS detector is to be used at the same time (e.g. with noisy signals).

$\pm \text{PK}/2$: Average of positive and negative peak-value measurement.

Softkey 6: AVE LEVEL (averaging factor)

Softkey 6 can be used to select an averaging factor for RMS and 1.41 RMS measurements. Four averaging possibilities are provided.

- 1: One measurement determines the result.
- 2: The result is the average of two measurements.
- 3: The result is the average of three measurements.
- 4: The result is the average of four measurements.

Each single measurement corresponds to the average of 5 AD measurements.

in IEC-bus mode, the single measurements are repeated following a delay time in the case of large changes in signal level.

The peak-value measurement is always performed with one cycle only.

Averaging factors are selected if reproducible results or a constant analog display are desired despite noise. The repetition rate of the measurements is of course reduced with high averaging factors.

Softkey 7: DEMOD (demodulator)

Softkey 7 offers the following alternatives:

OFF: Switching off demodulator
ON: Switching on demodulator
SQUELCH: Activation of squelch

The squelch switches on the demodulator with a sufficiently high IF level and switches it off at a low level.

Applications:

It is recommended to have the demodulator continuously switched on for remote measurements. The squelch function is activated if the noise of the uncontrolled demodulator results in interferences (e.g. before and after a transmitter burst of limited duration).

The OFF function (demodulator off) is provided as a precautionary measure for switching off e.g. a high-level signal at the output of the demodulator to prevent interference with other sensitive measurements in the CMS.

PK HLD Function

The demodulation mode for the PEAK HOLD function is based on the DEMOD function. Pressing the PK HLD softkey resets the display and stores the largest measured value of the positive peak-value meter until cleared again.

It is also possible with PEAK HOLD to program the full-scale value of the analog display just as with DEMOD. The setting of tolerance markers is also possible.

Using the functions "750- μ s deemphasis" and "Squelch" of the demodulator from the DEMOD submenu with the PEAK HOLD function is also advantageous.

Nevertheless, a submenu has not been produced for PEAK HOLD so that functions from the main menu which are used particularly frequently together with the PEAK HOLD function, e.g. decoding of a tone sequence, are not covered by the submenu. If these functions are required, they can be set in the DEMOD submenu and used for the PEAK HOLD function.

See Section 2.12 for further special functions.

2.4.4 AF Measurement

Softkey 4 is assigned two functions:

- DECODE (tone sequence decoding)
- COUNT (frequency measurement of demodulated or beat signal)

The shift key is used to select between first and second function.

DECODE Function

The tone sequence decoder is activated following actuation of `Softkey4/ENTER`. A decoding result is deleted if present in the display and the tone sequence decoder expects a sequence for decoding. Once this has arrived, it is output in two lines on the display together with the designation of the standard.

The digits 0 to 9 and possibly the special characters A to F are displayed, and also * and # with dual-tone sequences. X indicates a non-decodable frequency and P indicates a pause. The PEAK HOLD function is activated together with the decoding function since the modulation is usually also of interest in addition to the contents of the tone sequence.

DECODE Function : Submenu 1

The function DECODE branches into two submenus, which are output in the display fields next to softkeys 3 to 7. By pressing ENTER, the decoder can also be started from this menu.

| | | | | | | |
|---|------------------------|----|----|-------|---------|---------|
| 3 | <i>PREV</i> | No | Id | T[ms] | Frq[Hz] | Devi[%] |
| 4 | <i>TONE NUMBER</i> | 00 | 1 | 70 | 1060.7 | 0.0 |
| | | 01 | 2 | 70 | 1160.3 | 0.0 |
| | | 02 | 3 | 71 | 1272.2 | 0.1 |
| | | 03 | 4 | 71 | 1401.1 | 0.0 |
| | | 04 | 5 | 74 | 1533.2 | 0.1 |
| | | 05 | 6 | 69 | 1672.8 | 0.1 |
| 7 | <i>NEXT</i> | 06 | 7 | 70 | 1832.8 | 0.1 |

Fig. 2.4-9 DECODE submenu 1

This submenu reads out the contents of the decoded telegram in more detail. Each entry in the measurement buffer is identified by a sequential number starting with "0".

The column "T" gives the measured duration of each displayed tone.

With the tone sequence standards 1 to 9, additionally the frequency measured for each received tone is displayed in the column "FRQ [Hz]", as well as the deviation from the rated frequency in percent in the column "Devi [%]". No information will be shown for invalid tones or tone pauses or, as the case may be, dual tones. Restarting the decoder in submenu 1 causes the data of the new telegram to be output sequentially - beginning with "0" - when the tone sequence has been received completely.

Softkey 3: PREV (page down)

The display pages down to the previous page. This softkey has no function when the first page is already displayed.

Softkey 4: TONE NUMBER *) (printing of individual lines)

By programming `<TONE:NUMBER value>`, the contents of a respective line can be printed in the report. If no value is entered, all the lines are printed in form of a table.

Softkey 7: NEXT (page up)

The display pages up to the next page. This softkey has no function if the last tone that was decoded is already shown.

Note: *Submenu 1 is of no significance for standards 15 and 16 (CDCSS, ATIS)*

*) depending on model or option

DECODE Function: Submenu 2

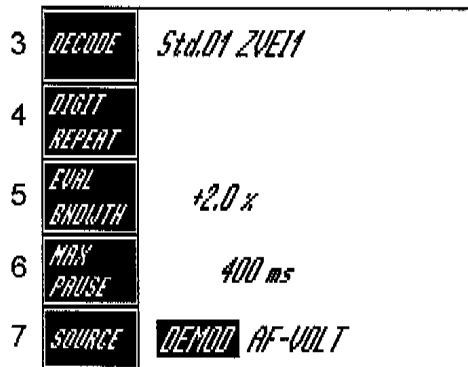

Fig. 2.4-10 DECODE submenu 2

Softkey 3: DECODE (tone sequence standard)

Softkey 3 is used to select the tone sequence standard. The entry is made using softkey 3/number/ENTER where each number is assigned a tone sequence standard.

Table 2.4-2

| Standard number | Unmodified | Modified |
|-----------------|-------------------------|----------|
| 0 | Std.0 fixed frequencies | Std.0 |
| 1 | Std.1 ZVEI 1 | Std.1 |
| 2 | Std.2 ZVEI 2 | Std.2 |
| 3 | Std.3 CCIR | Std.3 |
| 4 | Std.4 EEA | Std.4 |
| 5 | Std.5 EIA | Std.5 |
| 6 | Std.6 VDEW | Std.6 |
| 7 | Std.7 EURO | Std.7 |
| 8 | Std.8 CCITT | Std.8 |
| 9 | Std.9 NATEL | Std.9 |
| 10 | Std.10 DTMF | Std.10 |
| 11 | Std.11 VDEW direct dial | ----- |

Standards 1 to 9 are the most common single-tone sequences. To differentiate between unmodified and modified tone sequences, the CMS outputs the standard number and name in the display or, with modified tone sequences, only the standard number.

The assignment of frequencies to numbers is displayed in the definition menu for tones and can also be modified. Standard 0 reacts like a completely normal tone sequence standard. In

this case the frequencies are the fixed frequencies for the AF generators. Standard 10 is the dual-tone standard and cannot be modified for evaluation purposes.

Softkey 4: DIGIT REPEAT

Softkey 4 can be used to switch on/off the digit repeat. Since tone length information cannot be used for evaluation purposes, a double digit is not represented by an extra-long tone but by a tone followed by a further tone (tone E) as the repeat tone. The double digit appears with the digit repeat function switched on, the digit and the special character E appear with the digit repeat function switched off.

Softkey 5: EVAL BNDWTH (evaluation bandwidth)

The evaluation bandwidth of the decoder is programmed by entering softkey 5/number/ENTER. The number should be selected as the magnitude in % which is permissible as a positive or negative deviation from the rated frequencies. Frequencies within this window are decoded as valid. Frequencies outside this window are marked by X.

The tolerance window should not be extended too far, especially in the case of tone sequences with narrow frequency steps, since this could lead to overlapping of the tolerance ranges and thus ambiguous decoding results.

Softkey 6: MAX PAUSE (tolerable pause)

The decoder waits for brief pauses and then continues decoding. The tone sequence is considered to be terminated if the pauses are too long, then the result is displayed. This time limit can be defined using softkey 6/number/ENTER. The dimension of the number is ms.

This pause definition must not be confused with the pause between two tones which is defined in the standard and which can be influenced in the definition menu for tones. The latter is smaller than the previously defined time limit. A "P" is set during the evaluation if only the intertone pause is exceeded.

Softkey 7: SOURCE (signal source)

Softkey 7 is used to select either the demodulator or the AF voltmeter socket (AF/SCOPE) as the decoder source.

Option CMS-B27 serves to select standard 15 for CDCSS decoding or standard 16 for ATIS decoding using softkey DECODE under function DECODE in submenu 2.

Further details and applications of the decoder function are to be found in section 2.10.

COUNT Function

The frequency of the demodulated signal or the beat signal is counted by pressing softkey 4.

A relative measurement can be made in two different ways:

- The currently measured frequency is selected as the reference frequency by entering softkey 4/REF/ENTER.
- The frequency corresponding to the number is selected as the reference frequency by entering REF/number/dimension OR ENTER.

The relative result is the difference from the reference frequency. Relative measurements are identified by a sign in front of the result.

COUNT Function: Submenu

The COUNT function has a submenu which is output in the fields in the display next to softkeys 5 and 6.

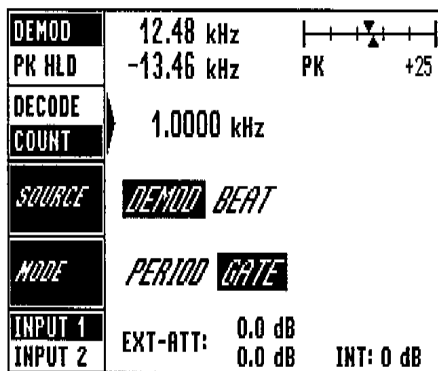

Fig. 2.4-11 COUNT submenu

Softkey 5: SOURCE (Signal source)

Softkey 5 can be used to switch between the signal sources DEMOD (demodulated signal) and BEAT (beat signal).

Since the beat measurement is usually carried out with an unmodulated signal, the AF generator of the CMS is switched off following the activation of softkey 4 (COUNT) provided that BEAT is selected.

Softkey 6: MODE (operating mode and resolution of counter)

There are two alternatives:

1. Period counting
2. Gate time counting

Period counting has a resolution of 0.1 Hz up to 100 kHz; the resolution is 1 Hz at frequencies above this value. Period counting is fast but requires a signal without noise.

Gate time counting is less sensitive to noisy signals.

2.4.5 Filter Selection

FILTER Function

Various AF filters can be switched on or off using softkey 5/ON or OFF. The IF and AF filters and their characteristic frequencies can be selected in two submenus.

FILTER Function: Submenu 1

The FILTER function branches to two submenus, which are both output in the display fields next to softkeys 4 and 7.

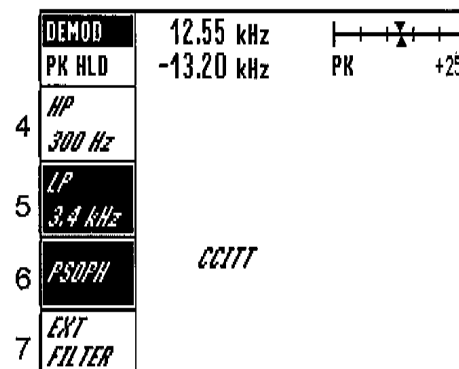

Fig. 2.4-12 FILTER submenu 1

Softkey 4: HP 300 Hz (300-Hz highpass)

Switching the 300-Hz highpass on and off.

Softkey 5: LP 3.4 kHz (3.4-kHz lowpass)

Switching the 3.4-kHz lowpass filter on and off.

Softkey 6: PSOPH (psophometric filter, option CMS-B5 or CMS-B39 or CMS-B20)*)

Switching the psophometric filter on and off. The psophometric filter is a CCITT filter or a C-message filter.

Softkey 7: EXT FILTER *)

Switching the external filter on and off. An input and output for the external filter are fitted to the rear of the device (CONTROL socket 47; pin 10 = input/pin 42 = output).

With the option CMS-B33*) installed, the same is activated and deactivated using EXT FILTER. In this case there is no longer any input and output for the external filter at the rear of the device.

The FILTER submenu 2 can be called by pressing the MENU ↓ (DOWN) key.

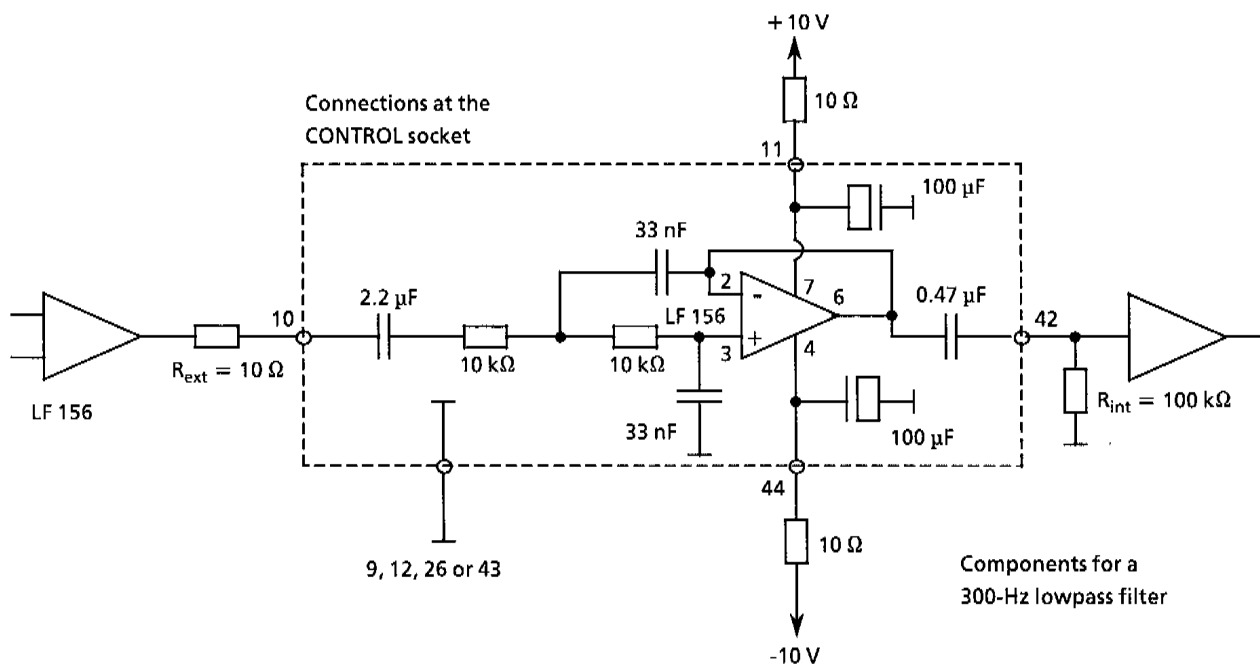

Fig. 2.4-13 Example of an external filter

*) depending on model or option

FILTER Function: Submenu 2

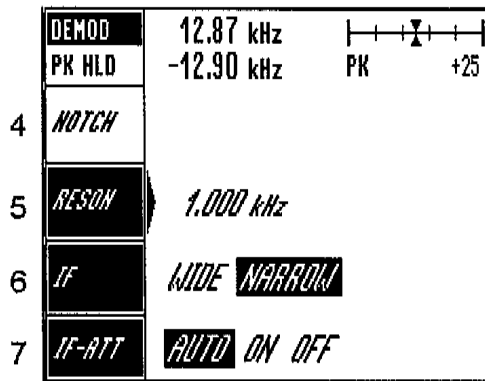

Fig. 2.4-14 FILTER submenu 2

Softkey 4: NOTCH (notch filter)

The notch filter is switched on using softkey 4/ON and off using softkey 4/OFF.

Stop frequency of notch filter:

The stop frequency of the notch filter is also selected using softkey 4. The entry is made using softkey 4/number/dimension OF ENTER.

Since the resolution of the set frequencies cannot always be set as required, the actually set frequency is output in the display.

Softkey 5: RESON (resonance filter)

The resonance filter is switched on using softkey 5/ON and off using softkey 5/OFF.

Resonance frequency of resonance filter:

Softkey 5 is used to select the resonance frequency of the filter. The entry is made using softkey 5/number/dimension OR ENTER. The actually set frequency is displayed as with the notch filter.

Filter combinations*)

For better understanding all filters can be envisaged as a series connection of three filter groups:

- Highpass filter - lowpass filter
- Psophometric filter - external filter
- Notch filter - resonance filter

Highpass and lowpass filters can be combined independently into four different filter configurations.

*) depending on model or option

The psophometric filter and the external filter cannot be combined, the same applies to the notch filter and the resonance filter. Since the notch filter is used for distortion and SINAD measurements, the last filter group cannot be used for evaluation during a distortion or SINAD measurement.

Notch filter and resonance filter are also being switched off when quitting or selecting a new RX test and TX test, since in this case SINAD or DIST measurements automatically continue to run.

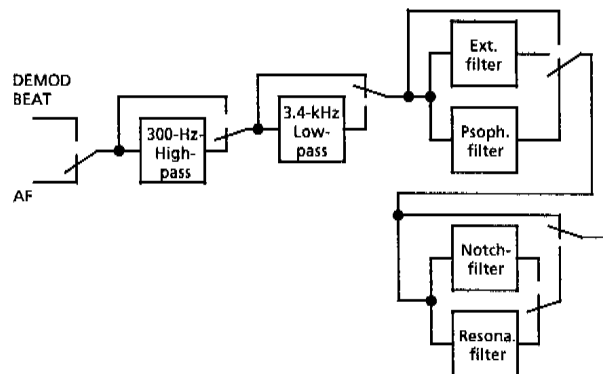

Fig. 2.4-15 Signal paths

Softkey 6: IF (IF filter)

The IF filter can be switched on and off using softkey 6. The IF bandwidth is limited to approx. 25 kHz by the NARROW filter. This improves the S/N ratio, especially when receiving small RF levels, but also results in a distortion at higher deviations and/or modulation frequencies.

Softkey 7: IF-ATT (IF attenuation)

The attenuator of the IF control can be switched on or off (important with AM demodulation). Also an automatic function is available.

The softkeys 6 and 7 are not displayed in the receiver test.

2.4.6 Distortion and S/N Measurements

Softkey 6 is assigned two functions:

- DIST (distortion measurement)
- S/N (S/N measurement)

The SHIFT key is used to select between first and second function.

DIST Function

The distortion measurement can be performed with the dimension % or dB. The test frequency may vary between 100 Hz and 4 kHz.

Dimension

The measurement is performed in dB by entering `softkey 6/dimension/dB` and in % by entering `softkey 6/dimension/%`.

Test frequency

The test frequency is defined using `softkey 6/number/dimension/Hz` OR `kHz`.

The full-scale value can also be influenced in the analog display for the distortion measurement:

The currently measured value is used to define the full-scale value by entering `softkey 6/RANGE/%` OR `dB` OR `ENTER`.

A number is used to define the full-scale value by entering `Softkey 6/RANGE/number/%` or `dB` or `ENTER`.

Tolerance markers can be set in the analog display using the same syntax: `softkey 6/TOL/number/%` or `dB` or `ENTER`.

DIST Function: Submenu

The DIST function branches into one submenu, which is output in the display fields next to softkeys 5 and 7. Softkey 6 is assigned to the main menu.

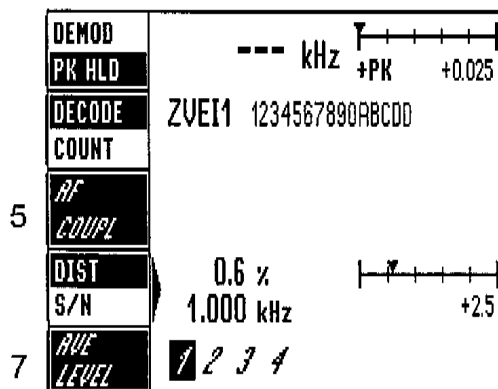

Fig. 2.4-16 DIST submenu

Softkey 5: AF COUPL (test frequency)

Softkey 5 can be used to define whether the test frequency selected in the main menu under distortion is also to define the frequency of the modulation generator or not.

Application:

Generally, coupling offers advantages. The modulation generator supplies the signal to be measured by the distortion meter following the device-under-test. However, coupling is switched off if the radiotransmitter has a scrambler, and the modulation generator signal is set independently of the distortion test frequency.

Softkey 7: AVE LEVEL (averaging factors)

Softkey 7 selects four averaging factors:

- 1: One measurement determines the result.
- 2: The result is the average of two measurements.
- 3: The result is the average of three measurements.
- 4: The result is the average of four measurements.

Each single measurement corresponds to the average of five AD measurements.

In IEC-bus mode, the single measurements are repeated after a delay time in the case of large changes in signal level.

S/N Function

Whereas the wanted signal is masked out by a filter in the case of a distortion measurement, it is switched off with the S/N measurement.

This measurement can also be performed in two dimensions; the dimensions are selected by entering `softkey 6/dimension %` OR `dB`.

The current measured value is used to define the full-scale value in the analog display by entering `softkey 6/RANGE/%` OR `dB` OR `ENTER`.

The entered numeric value is used to define the full-scale value by entering `softkey 6/RANGE/number/% OF dB OF ENTER`.

Tolerance markers can be set in the analog display by entering `softkey 6/TOL/number/% or dB OF ENTER`.

S/N Function: Submenu

The S/N function branches to one submenu which is output in the display fields next to softkeys 5 and 7. Softkey 6 remains assigned to the main menu.

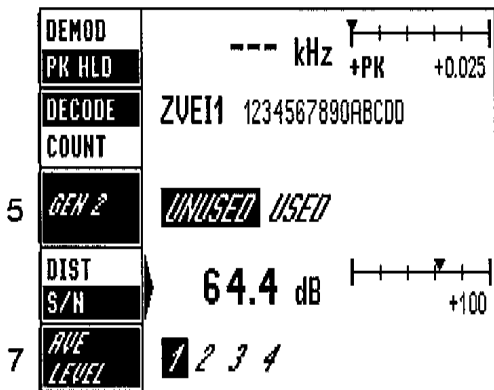

Fig. 2.4-17 S/N submenu

Softkey 5: GEN 2 (modulation generator 2)

The wanted modulation signal is switched on and off alternately in the course of the S/N measurement. Softkey 5 is used to select whether the modulation generator 2 is to follow this rhythm or not.

Softkey 7: AVE LEVEL (averaging factors)

Softkey 7 selects four averaging factors:

- 1: The result is the average of one signal measurement and two noise measurements.
- 2: The result is the average of one signal measurement and three noise measurements.
- 3: The result is the average of two signal measurements and four noise measurements.
- 4: The result is the average of two signal measurements and five noise measurements.

Each single measurement corresponds to the average of five AD measurements.

In manual operation and IEC-bus mode, the single measurements are repeated after a delay time in the case of large changes in signal level. Different S/N ratios (measurement times) may result.

2.4.7 Input Switchover

INPUT 1/INPUT 2 Function

The selected RF input (RF IN/OUT or RF 2) is shown in inverted form. The other input can be selected by entering `SHIFT/ softkey 7`. It is possible to inform the CMS of the attenuation value connected prior to the associated input. By entering `softkey 7/number/dB or ENTER` the CMS takes into account the entered attenuation for the level with RF measurement and setting.

INPUT 2 Function: Submenu *)

An additional internal 24-dB attenuator can be cut in for measurements via the connector RF IN 2.

The attenuator is switched on/off manually in a submenu which can be opened via the INPUT 2 softkey in the TX test.

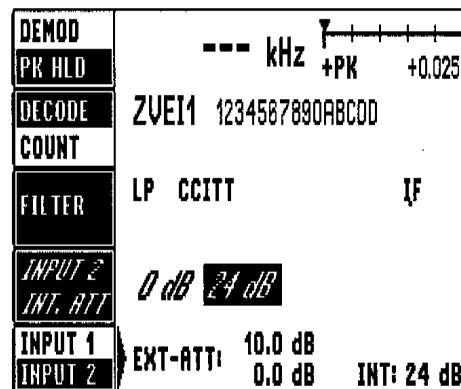

Fig. 2.4-18 INPUT2 submenu

The attenuator status is indicated adjacent to the INPUT 2 softkey in the TX and DX main menu.

*) depending on model or option

2.4.8 Lock

LOCK Function

Softkey 8 is assigned a simple changeover key function.

If the LOCK mode is active, TX test can only be reached by operation in the RX test. With the LOCK function deactivated the switchover from RX test to TX test is only possible by applying an RF power to the RF IN/OUT socket 29. The RX test is automatically activated again by an RF voltage drop. This return to RX test can, however, be eliminated when switching over to the TX test via keys or by calling a submenu in the TX test.

Application:

The LOCK status is used if discontinuous transmitter tests are performed, e.g. power pulses of limited duration with superimposed modulated data messages. The LOCK function prevents the CMS from returning to the receiver test following each pulse. A typical example is an acknowledge call. The LOCK function is automatically switched on in this case and with certain other measurements such as e.g. cellular radio.

2.4.9 Modulation Generators

Softkey 9 is assigned all functions of the first modulation generator, softkey 10 those of the second modulation generator. The frequency is the first function and the level of the modulation generator is the second. Switching between the two functions is possible by entering `SHIFT/softkey 9 OR 10`.

AF1/AF2 Function

The frequency is entered using `softkey 9 OR 10/number/dimension OR ENTER`. The modulation generator is switched off by entering `softkey 9 OR 10/OFF`. This switch-off function for the level with a frequency entry has the following purpose:

*) depending on model or option

The levels of tone sequences generated naturally by modulation generators are set using the level function. If the modulation generator is not switched off using the above-mentioned method, the valid continuous tone is output before and after the tone sequence. The modulation generator can be switched on again using `softkey 9 OR 10/ON`.

Variation function

The variation increment for the VAR spinwheel can be entered using `softkey 9 OR 10/VAR/number/dimension OR ENTER`. In contrast to usual operation, `VAR/0/ENTER` does not set the minimum increment but leads to variation with the fixed frequency series (see VAR function, Section 2.3.2.2.1 and definition menu for tones, Section 2.10).

Reference function

The selected frequency is defined to be the reference by entering `REF/number/dimension OR ENTER`. The set frequencies must be understood as a difference from the reference frequency (see REF function, Section 2.3.2.2.1).

LEV1/LEV2 Function

Since the source impedance*) of the modulation generator is very low (approx. 2 Ω), the set level is to be understood as the EMF.

The modulation generator level is entered using `softkey 9 OR 10/number/dimension OR ENTER`. The power is referred to 600 Ω when the dimension dBm is selected. The level is switched off using `softkey 9 OR 10/OFF`, and the previously valid level is switched on again using `softkey 9 OR 10/ON` (a special method for switching off the level is described with the AF1/AF2 function). Calling the beat frequency measurement automatically switches off the two modulation generators.

Variation function

The variation increment on the VAR spinwheel can be set using `softkey 9 OR 10/VAR/number/dimension OR ENTER`.

Application:

The modulation signal must be overloaded by 20 dB in the case of certain measurements. It is recommendable to enter `softkey 9 OR 10/VAR/`

20/dB in this case. One step on the VAR spinwheel switches the 20-dB overload on and off independent of the selected level.

Reference function

The variation increment for the level on the VAR spinwheel can be set using **softkey 9** or **10/REF/number/dimension OF ENTER**.

2.4.10 Oscilloscope / DC Measurement

The scope mode is activated by means of the softkey **SCOPE MODE**. If the active cursor is located at this position, a submenu may be called for handling the signal sources for the scope and activating the DC measurement.

If the active cursor is located at this position, it can also mean when entering

- <CLEAR> : Switching on the FREEZE mode. Signal recording is stopped. "FREEZE" appears in the display.
- <ENTER>: Switching off the FREEZE mode. Signal recording continues.

Quitting the current main menu leads to deactivation of the FREEZE mode.

SCOPE MODE Function

Softkey 12: BEST RANGE

The automatic amplitude scaling can be switched on and off using this softkey. With the automatic amplitude setting switched on, the best gain (filling the complete format) is set in steps of 1-2-5. The associated scale is displayed on the scope screen.

Softkey 13: AMP (amplitude setting)

With softkey 13 activated (active cursor), the gain setting can be selected manually in steps of 1-2-5 using the VAR spinwheel.

Softkey 14: TIME (time scaling)

If softkey 14 is activated, the time scale can be varied using the VAR spinwheel in steps of 1-2-5.

If the active cursor is on softkey 13 or 14, values can be directly entered. Assignments can be looked up in Table 2.4-3.

Table 2.4-3

| Input value | Scope | | Settling | | |
|-------------|-----------|-----------|-----------|----------------|-----------|
| | AMP kHz/□ | TIME ms/□ | AMP | | TIME ms/□ |
| | | | Power dB□ | Frequency kHz□ | |
| 0 | - | 50 | - | - | - |
| 1 | 50 | 20 | 1 | 5 | 0.05 |
| 2 | 20 | 10 | 2 | 1 | 0.1 |
| 3 | 10 | 5 | 5 | 2 | 0.2 |
| 4 | 5 | 2 | 10 | 5 | 0.5 |
| 5 | 2 | 1 | 20 | 10 | 1 |
| 6 | 1.0 | 0.5 | - | 20 | 2 |
| 7 | 0.5 | 0.2 | - | 50 | 5 |
| 8 | 0.2 | 0.1 | - | - | 10 |
| 9 | 0.1 | 0.05 | - | - | 20 |
| 10 | 0.05 | - | - | - | 50 |
| 11 | - | - | - | - | 100 |
| 12 | - | - | - | - | 200 |
| 13 | - | - | - | - | 500 |
| 14 | - | - | - | - | 1000 |
| 15 | - | - | - | - | - |
| 16 | - | - | - | - | - |

Softkey 15: Y POS (Y-position)

Activating softkey 15 allows for shifting the position of the displayed signal in the vertical direction using the VAR spinwheel.

SCOPE MODE Function: Submenu 1

The SCOPE MODE function has a submenu which is displayed in the fields next to softkeys 11 to 15.

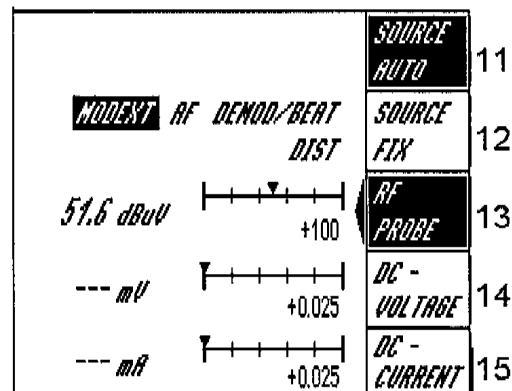

Fig. 2.4-19 SCOPE MODE submenu

Softkey 11: SOURCE AUTO

(automatic signal source selection)

If softkey 11 is used to switch on the automatic source selection, the demodulated signal is automatically displayed in the transmitter test and the signal at the AF/SCOPE connector in the receiver test.

Softkey 12: SOURCE FIX (manual selection of signal source)

AF: AF signal at AF/SCOPE connector

DEMODO/BEAT: Selection of demodulated signal or beat signal. The beat signal is displayed on the scope screen.

MOD EXT: Modulation input for external signals.

DIST: When this softkey is activated, the signal path SOURCE DIST shown in Fig. 2.4-20 will be applied to the scope.

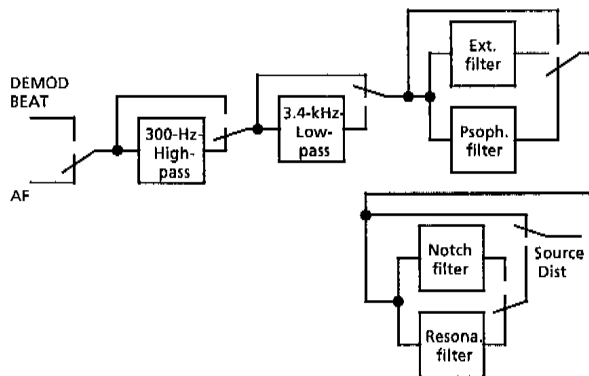

Fig. 2.4-20 Signal paths

Softkey 13: RF PROBE *)

Softkey 13 starts and stops the RF-PROBE measurement. Possible display units are mV as well as dB μ V, W and dBm. It should be noted, however, that the latter two units refer to the probe being terminated by 50 Ohms only, since the RF-probe measures voltages, not power. As a result, a probe not being terminated would lead to a 6 dB increase in power. Further on this issue, setting signal source and CMS in W or dBm might lead to overloading the probe if executing measurements at the limit of the chosen RF probe type (i. e. if a terminator is removed).

Input of a value between 0 and 60 dB followed by ENTER allows an external attenuation to be accounted for in the measurement result. In the display this is marked by a "!" leading the result, as well as a display of the chosen attenuation beneath the analogue range bar. These markings are removed as soon as an external attenuation of 0 dB is entered.

*) depending on model or option

Softkey 14: DC-VOLTAGE *)

The DC voltage measurement is initiated by pressing softkey 14. The voltage between the V_{DC} connectors on the rear panel is displayed in digital as well as analog form. The measurement is stopped by pressing the CLEAR key or again the softkey 14.

Softkey 15: DC-CURRENT *)

The DC current measurement is initiated by pressing softkey 15. The current is determined using a shunt of 50-m Ω between the I_{DC} connectors on the rear panel and displayed in digital as well as analog form.

The measurement is stopped by pressing the CLEAR key or again the softkey 15.

Note: DC voltage and DC current measurements are possible simultaneously. Measurement errors can occur in case of RF fields >0.5 V/m.

2.4.11 Settling Option *)

SCOPE MODE Function: Submenu 2 *)

The settling option permits to record the behaviour of a mobile phone with respect to power and frequency while being switched on/off and over.

The settling submenu can be reached as the second submenu via the key SCOPE MODE in the TX test main menu.

2.4.11.1 Description of Controls and Display Elements

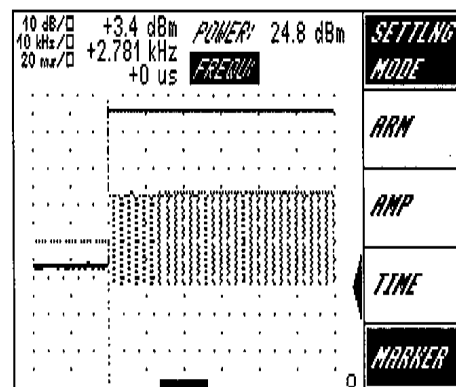

Fig. 2.4-21

The settling submenu consists of five softkeys: SETTLING MODE, ARM, AMP, TIME and MARKER.

Softkey 11: SETTling MODE

Selection between power and frequency recording. After entering the Settling submenu, POWER is always set if a power ramping has not yet been recorded. If FREQU is active when opening the menu, the unit is automatically set to FM.

Softkey 12: ARM

By pressing this key, the CMS is set to the ready status. The key is shaded, and the occurrence of the trigger event is waited for. A message in the status line indicates the trigger threshold required for triggering the event. By pressing the key again, the ready status can be cancelled. The status line displays the message 'Settling cancelled'.

Softkey 13: AMP

This key is used to set the amplitude scale for recording. It can be varied using the rotary knob.

Depending on the setting of the SETTling MODE key, the amplitude is varied for recording power or frequency.

After a curve has been recorded, it can be zoomed in the y-direction using the rotary knob, provided that the active cursor is positioned on this key.

Softkey 14: TIME

This key permits to set the time scale for recording. It can be varied using the rotary knob.

The setting applies to power and frequency recording and is therefore independent of the setting of the SETTling MODE key.

After a curve has been recorded, it can be zoomed in the x-direction using the rotary knob, provided that the active cursor is positioned on this key.

If the active cursor is on softkey 13 or 14, values can be directly entered. Assignment can be looked up in Table 2.4-3.

Softkey 15: MARKER

This key permits to vary the marker position within a recorded curve using the rotary knob. The x and y-value of the marker position is indicated in the display.

The following display elements are provided in the Settling submenu:

- Amplitude scale in dB/div for recording the power
- Amplitude scale in kHz/div for recording the frequency
- Time scale in s/div. This applies to the power and frequency curve.
- Marker position. The amplitude values are indicated for the power and the frequency curve separately. The x-position of the marker (time) applies to both curves. As long as no curve has been recorded yet, --- is indicated as the marker position.
- Setting of the SETTling MODE key. Possible settings are POWER and FREQU.

2.4.11.2 Power Measurement

This measurement uses a change of the RF level as trigger event.

Before entering the settling menu, switch from COUNT to SET RF and set the RF frequency of the test item.

When the settling menu is entered, all data recorded before are deleted and the SETTling MODE key is set to the POWER position.

The measurement can be made both via RF input 1 and via RF input 2.

The measurement is started by pressing the ARM key. The softkey is shaded, and the 2nd status line displays a message, indicating the RF level used for initiating the trigger event. The CMS automatically detects whether RF power is applied to the connector and decides whether to measure settling or decaying of power.

The trigger level is determined as follows:

Table 2.4-4

| Type of meas | Power settling | Power decay |
|--------------|----------------|-----------------------|
| RF Input 1 | 5 dBm | Measured power -20 dB |
| RF Input 2 | -70 dBm | Measured power -20 dB |

In order for the trigger level not to be too far in the noise when the power decays, it cannot become smaller than -1 dBm for measurements via RF input 1 and smaller than -76 dBm for measurements via RF input 2.

As long as the trigger event has not yet occurred, the CMS is in the free-running mode, ie the signal curve at the RF connector is indicated in the display of the oscilloscope without trigger.

After the trigger event has occurred, the message 'Trigger found' is output in the 2nd status line.

The end of recording is indicated by the message 'End of sampling'. Its duration depends on the setting of the time scale and may be up to 40 seconds with 1s/div.

With the message 'End of sampling', the ARM key is unshaded, and the marker line is positioned in the first third, in the middle or in the last third of the curve, depending on the mode of measurement settling or decaying. The rotary knob symbol is set to the MARKER key. It is then possible to follow the recorded curve using the rotary knob and read off the respective marker values in the display.

Besides, it is possible to expand the recorded curve by varying the amplitude or time scale. The amplitude scale can be zoomed at will in the y-direction, whereas, in the x-direction, two steps up and down are possible starting from the setting during recording.

The user can abort recording at any time by pressing the ARM key again, leaving the Settling menu or actuating any other function which is not associated with the Settling measurement. The message 'Settling cancelled' is produced and the already recorded data are cleared.

A recorded curve can be cleared by pressing the CLEAR key if the active cursor is positioned on the keys AMP, TIME or MARKER.

2.4.11.3 Frequency Measurement

With this measurement, a change of the RF frequency is used as the trigger event. The measurement sequence is similar to that of the power measurement.

The SETTLING MODE key must be set to the FREQU. position.

The trigger level is set to ± 8 kHz by the CMS irrespective of the power applied to the RF connector.

2.4.11.4 Combined Power and Frequency Measurement

To enable simultaneous indication of the power and frequency curve in the display, two measurements must be recorded. A combined measurement is automatically performed when a curve is already visible which was recorded before switching over the SETTLING MODE key.

The following combined measurement sequences are possible:

Table 2.4-5

| SETTLING MODE 1st measurement | Power is applied to CMS | Type of 2nd measurement | Trigger level of 2nd measurement | |
|----------------------------------|-------------------------|-------------------------|----------------------------------|------------------------------------|
| | | | Input 1 | Input 2 |
| FREQU FREQU | no yes | Settling Switchover | ± 8 kHz ± 8 kHz | ± 8 kHz ± 8 kHz |
| POWER POWER | no yes | Settling Decay | 5 dBm Power at CMS -20 dBm | -70 dBm Power at CMS -20 dBm |

The setting of the SETTLING MODE key for the first measurement determines whether power or frequency variation is used as trigger event. After recording of the curve, the SETTLING MODE key must be actuated to enable the second measurement to be performed. The trigger level of the second measurement is always equal to the trigger level of the first measurement. This is necessary for the two records to feature a time relationship to each other. Therefore, the test item must be equally operated for both records.

The power curve is indicated by a continuous line, whereas the frequency curve is represented by a dotted line.

The two curves can be cleared simultaneously by pressing the CLEAR key, if the active cursor is set to the MARKER key. The SETTLING MODE key automatically changes to the POWER position.

If the active cursor is positioned on the AMP or TIME key, only one of the two curves can be cleared by pressing the CLEAR key depending on the setting of the SETTLING MODE key.

If the message 'End of sampling' is displayed in the status line at the end of recording, this message must be cleared first by pressing the CLEAR key before a curve can be cleared.

Note:

After sending an ARM command via IEEE bus or AUTORUN control, synchronization needs to be provided by the user. This way, it is possible to enable the push-to-talk function of a mobile through a remote command, for example by using one of the CMS relais or TTL-lines *). A command of this kind might then be followed by a function like HOLD, PAUSE or WAIT FOR KEY (SPEC 2 menu) to ensure synchronization.

Clearing the curves:

Table 2.4-6

| Key | Active cursor | SETTLING MODE | Cleared curves |
|-------|---------------|---------------|-----------------|
| clear | MARKER | --- | both |
| clear | AMP/TIME | POWER | power curve |
| clear | AMP/TIME | FREQU. | frequency curve |

Input value ranges are shown in Table 2.4-7. Entries for the AMP and TIME parameters are converted to the nearest setting in accordance with Table 2.4-3.

Table 2.4-7

| | Default | Maximum value | Minimum value |
|-------------------------|------------|---------------|---------------|
| SETTLING MODE | POWER | --- | --- |
| Amplitude scale: | | | |
| Power measurement | 10 dB/Div | 20 dB/Div | 1 dB/Div |
| Frequency measurement | 10 kHz/Div | 50 kHz/Div | 500 Hz/Div |
| Time scale | 5 ms/Div | 1 s/Div | 0.05 ms/Div |

*) depending on model or option

2.5 Receiver Test (RX-Test)

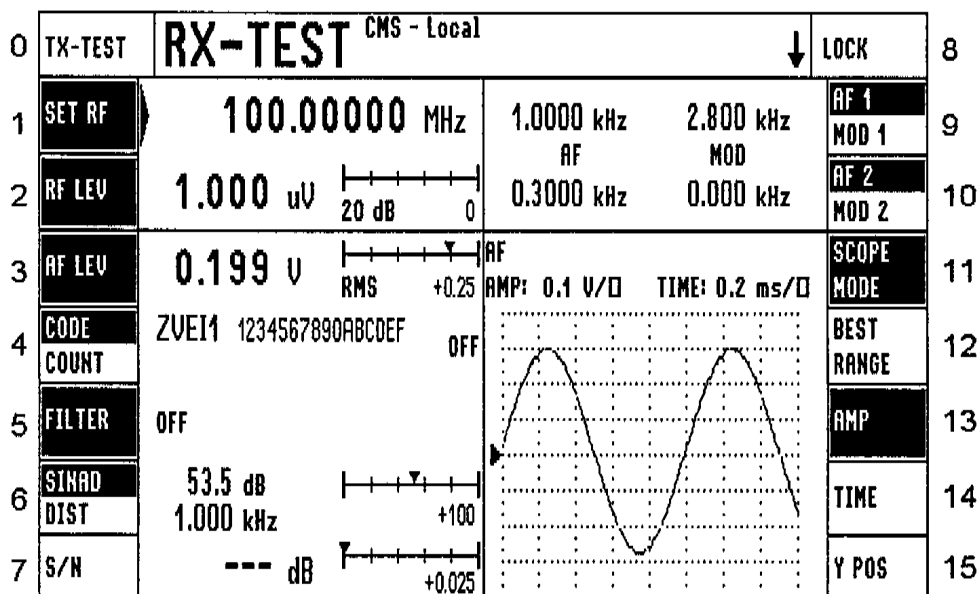

Fig. 2.5-1 Main menu RX test

Starting with the main menus of the selection menu, the main menu RX-TEST (receiver test) can be reached by pressing the softkey RX-TEST.

It contains all controls required to carry out a standard receiver test. Almost every function contains submenus. These contain controls which can be used for more seldom receiver test functions.

Softkey 0 can be used to directly branch to the main menu for the transmitter test (TX-TEST).

2.5.1 RF Frequency Setting

SET RF Function

The signal generator frequency of the instrument can be set using the SET RF function. This function is entered by means of sequence SET RF/number/dimension OR ENTER.

The signal generator frequency setting can be varied using the VAR function and the VAR spinwheel.

The signal generator frequency setting can also be made in relative mode.

The reference frequency is entered using softkey SET/REF/ENTER, if the current frequency is to become the reference frequency, or using softkey SET REF/number/dimension OR ENTER if another frequency is to be set as the reference frequency.

SET RF Function: Submenu 1

This menu is described in the TX test (see Section 2.4.1).

SET RF Function: Submenu 2

The second submenu SET RF offers an automatic change of the RF frequency. This can be done step by step but also continuously, similar to a sweep generator.

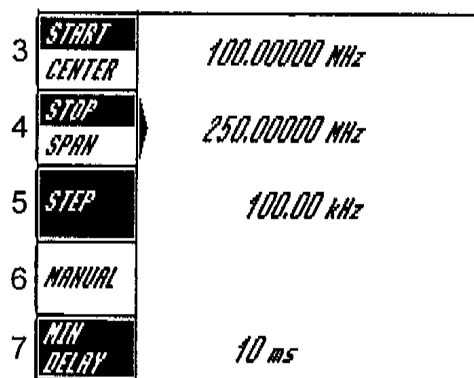

Fig. 2.5-1a SET RF Submenu 2

Softkey 3: START / CENTER

This key either allows the entry of a start frequency (if the upper half of the softkey is shown in inverse video) or the entry of a center frequency for the span covered by the RF generator. The other half of the key results in a switchover to softkey 4. If the main menu RX test is opened from menu SPECTRUM, it has to be noted that the functions on softkey 3 correspond to those on softkey 7 in the spectrum mode and that they influence each other. In this case, values set in menu SPECTRUM do not have to be entered again. With a negative step width (function STEP) set, the upper half of the key (START) represents the maximum final value of the sweep.

Softkey 4: STOP / SPAN

The stop frequency of the range to be covered or - with the lower half of the softkey being activated - the frequency span can be entered here. For switchover to the CENTER/SPAN display press softkeys 3 or 4 a second time. If the main menu RX test is opened from menu SPECTRUM, it has to be noted that the functions on softkey 4 correspond to those on softkey 15 in the spectrum mode and that they influence each other. In this case, values set in menu SPECTRUM do not have to be entered again. With a negative step width (function STEP) selected, the upper half of the key (STOP) represents the start value of the sweep.

Softkey 5: STEP

The step width of the RF transmit frequency can be set by means of this function. The resolution corresponds to that of SET RF (softkey 1). The selected unit can but does not have to correspond to the units of softkey 3 or 4. By entering a negative number, the RF generator of CMS can be made to run from high to low frequencies. If this is the case, the sweep starts at the STOP frequency (softkey 4) and goes down towards the START frequency defined by the upper half of softkey 3. The start frequency of a sweep is always set, the stop frequency of a sweep only if it matches with the spacing defined by STEP. If this is not the case, the current start frequency is continued before the end of the sweep is attained.

Softkey 6: MANUAL

This softkey switches between the continuous and single-step mode of the sweep generator. If the key is in inverse video, the frequency selected and displayed under SET RF is only changed if the ENTER/ON key is pressed. The RF frequency is varied in this single-step mode until softkey 6 is pressed. The key will no longer be in inverse video but be white again. If the active cursor is already on this key, the MANUAL function can also be switched on/off using ENTER/ON and CLEAR/OFF.

Softkey 7: MIN DELAY

This key allows to determine the delay between subsequent frequencies set by the unit. With softkey 6 activated (ie in inverse video), this entry will not be taken into account. It has to be noted that a minimum delay is obtained when varying the RF synthesizer. The magnitude of this delay depends on the step width for the SET RF frequency set under STEP (softkey 5). Waiting periods of 30 ms have to be reckoned with at the switchover points (110, 375 and 750 MHz) of the CMS synthesizer to allow for a complete settling. The entry - always without the unit - and the display are generally based on milliseconds (ms). Moreover, entered values are to be considered as minimum delays as mentioned above.

2.5.2 RF Level Setting

RF LEV Function

The signal generator level can be set using the RF LEV function. The entry is made using `softkey 2/number/dimension` or ENTER. If a number is not entered, this sequence can be used to convert the dimension of the set level.

The RF level can be switched off temporarily using **softkey 2/OFF**. The previously valid level can be switched on again using **softkey 2/ON**.

If the option CMS-B34 is fitted, higher output levels are output at the connector RF OUT 2. This is indicated in the display as follows: "OUT 2".

Whereas directly entering parameters or varying parameters using the VAR spinwheel are simply different methods of operation which lead to the same result, adjustment of the RF level using keys or the VAR spinwheel leads to different results.

The interrupt-free electronic level fine variation is used for varying the level to smaller values by means of the VAR spinwheel. The level can be reduced interruption-free by 19.9 dB in FM and ϕ M modes, and by 4.9 dB in AM mode. The range used by the electronic level fine variation for the reduction in level is indicated in the analog display (in the field next to softkey 2) by a marker leading from right to left. On the other hand, setting the level using the digital keypad mainly uses the mechanical attenuators (audible switching).

Note: *Frequent level variations in automatic test systems might reduce the service lifetime of the attenuator. It is therefore recommended to carry out the level settings in few steps only, using the electronic level variation if possible.*

Application:

The interrupt-free electronic level fine variation is used to search for the squelch point and the squelch hysteresis of the radio receiver. On the other hand, entering the level on the digital keypad always results in the optimum broadband S/N ratio of the CMS signal generator, increased level accuracy and a reduced AM distortion factor.

The variation increment can be set using **softkey SET RF/VAR/number/dimension** or **ENTER** (see function-based hardkeys (VAR), Section 2.3.2.2.1 and spinwheel, Section 2.3.2.3).

The signal generator level setting can also be made in relative mode. The reference level can be entered using **softkey SET/REF/ENTER** if the current level is to become the reference level, or using **softkey SET/REF/number/dimension** or **ENTER** if a different level is to be set as the reference level.

RF LEV Function: Submenu

The RF LEV function has a very important submenu which contains the automatic test routines of the receiver test. The RF LEV submenu is output in the display fields next to softkeys 3 to 5 and 7.

It is important with the automatic test routines to ensure that the radiotelephone is completely connected to the CMS. The connectors RF IN/OUT and AF/SCOPE are used for this purpose.

Since the automatic test routines may require a lengthy period of time, they can be aborted during the measurement by pressing the RF/LEV softkey.

| | | |
|---|---------------------|--------------------------|
| 3 | BNDWTH MEAS | --- Hz BANDWIDTH |
| | | --- Hz FRR OFFSET |
| 4 | SQUELCH MEAS | |
| 5 | QUIET | |
| | | |
| 7 | LEVEL | PD EMF 2nd |

Fig. 2.5-2 RF LEV submenu

Softkey 3: BNDWTH MEAS (bandwidth measurement)

Softkey 3 starts the bandwidth measurement.

The measurement is run as follows:

1. Initial setting: RF frequency = nominal receiver center frequency. The receiver squelch is switched off.
2. Definition of the AF noise level with RF level switched off.
3. Increase in RF level until the AF noise level has decreased by 10 dB. Storage of AF noise level.
4. Increase in RF level by further 6 dB.

*) depending on model or option

5. Offset of RF frequency to higher frequencies until the AF noise level of point 3 is obtained again.
6. Offset of RF frequency to lower frequencies until the AF noise level of point 3 is obtained again.
7. The receiver band limits defined under points 5 and 6 serve for determining the receive bandwidth and the center frequency offset. These two values are displayed.

Softkey 4: SQUELCH MEAS
(squench measurement)

Softkey 4 starts the squench measurement.

The measurement is run as follows:

1. Initial setting: The RF level is set to the minimal value. The receiver squench is switched on.
2. The RF level is increased interrupt-free until the AF level is switched on on the radiotelephone. This is the squench switch-off point.
3. The RF level is decreased until the AF level on the radiotelephone is switched off again. The squench hysteresis is the difference between the two RF levels.
4. Squench inset and squench hysteresis are displayed.

Softkey 5: QUIET
(quieting measurement)

The quieting measurement is initiated via `Softkey 5/number/dimension dB` or `ENTER`. The number in dB corresponds to the quieting criterion.

The measurement is run as follows:

1. Initial setting: RF frequency = receiver center frequency. RF level = off. The receiver squench is switched off.
2. The AF noise level is measured.
3. The RF level is increased until the AF noise level has decreased by the number specified as the quieting criterion.
4. This RF level is displayed as result.

Softkey 7: LEVEL
(EMF-PD switchover)

Softkey 7 can be used to select whether the output RF voltage is to be displayed as a no-load voltage (EMF) or as a terminal voltage (PD) across a 50-Ω load.

2.5.3 AF Level Measurement

AF LEV Function

The AF level measurement is selected by pressing softkey 3. The dimension can be selected by subsequently pressing a dimension key; the dimensions mV, W, dBμV and dBm are possible. Measurements in W and dBm are usually based on a load resistance of 600 Ω. This can be changed, however, in the definition menu for special functions. (Section 2.12).

Tolerance markers can be set in the analog display using `softkey 3/TOL/number/dimension` or `ENTER`.

The currently measured value is used to define the full-scale value on the analog display using `softkey 3/RANGE/dimension` or `ENTER`. The value corresponding to the number is used to define the full-scale value using `softkey 3/RANGE/number/dimension` or `ENTER`.

The current measured value is defined as the reference value using `softkey 3/REF/dimension` or `ENTER`, and the subsequent measurements are made in dB referred to this value. A reference value can be defined using `softkey 3/REF/number/dimension` or `ENTER`. An integer multiplier, which is then part of the AF-LEV result, can be specified using `Softkey 3/number/ENTER`.

AF LEV Function: Submenu

The AF LEV function has a submenu which is output in the fields in the display next to softkeys 4 to 7.

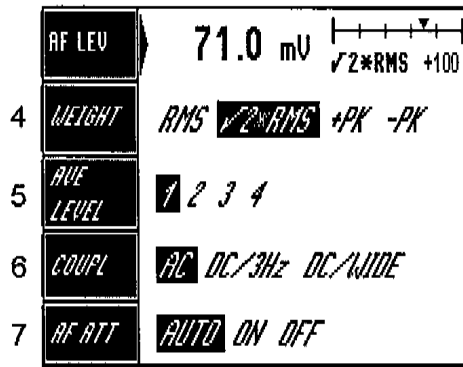

Fig. 2.5-3 AF LEV submenu

Softkey 4: WEIGHT

Softkey 4 can be used to select four different types of weighting.

- RMS: Real RMS weighting
 - $\sqrt{2} * \text{RMS}$: Real RMS weighting multiplied by 1.41.
 - + PK: Positive peak weighting
 - PK: Negative peak weighting
- This weighting is used if the peak value is to be determined when modulating with sinewave signals, and the integrating effect of the RMS detector is to be used at the same time (e.g. with noisy signals).

Softkey 5: AVE LEVEL (averaging factor)

Softkey 5 can be used to select an averaging factor for RMS and $\sqrt{2} * \text{RMS}$ weighting. Four averaging possibilities are provided.

- 1: One measurement determines the result.
- 2: The result is the average of two measurements.
- 3: The result is the average of three measurements.
- 4: The result is the average of four measurements.

Each single measurement corresponds to the average of 5 AD measurements.

In IEC-bus operation, the single measurements are repeated with high changes in signal level following a delay time.

Application:

A higher averaging factor results in more reproducible results compared to a single measurement especially in the case of noisy signals. An average measurement takes longer, however. The AF voltmeter is often used in the receiver test to measure the AF noise of the receiver which is not supplied with an RF signal. The reproducibility of these noise measurements is improved by averaging.

Averaging is not carried out for peak weighting.

Softkey 6: COUPL (AC/DC coupling)

Softkey 6 can be used to couple the detectors to the signal source in three different manners:

- AC coupling: Only AC voltages ≥ 50 Hz are measured.
- DC / 3Hz: Pure DC measurement. AC components above 3 Hz are suppressed.
- DC / WIDE: AC and DC components are RMS or peak weighted together.

Softkey 7: AF ATT (input divider)

The CMS has a selectable input voltage divider in order to expand the dynamic range of the measurement points at higher values. This is usually switched on or off automatically depending on the measured value.

If the automatic feature does not meet all requirements, it can be switched off (e.g. to save time).

Selection is possible using softkey 7 between:

- AUTO: Automatic adaptation to measured value
- ON: A dynamic range of 24 dB is lost at small measured values.
- OFF: Top limit of measuring range approx. 1.4 V.

2.5.4 Code, Count

Softkey 4 is assigned two functions:
 CODE (Code outputs)
 COUNT (AF frequency counting)

The first or second function is selected using the SHIFT key.

CODE Function

An already stored selective call can be sent to the radiotelephone via the RF path using `softkey 4/ENTER`.

A new call number can be entered and sent using `softkey 4/number/ENTER`. The digits can be 0 to 9 and A to F, and also * and # with dual-tone sequences. A sequence with up to 30 digits can be entered.

A tone sequence can be incorporated in a continuous tone of constant modulation or output as a modulation burst. Section 2.5.9 describes the setting of the two modes.

Code Function: Submenu 1

The CODE function has two submenus which are output in the fields in the display next to softkeys 3 to 7.

These submenus are used for the most significant configurations in conjunction with code transmissions.

Other configurations which are required less often, but then for longer periods, are set up in the "Definition menu for tones" (Section 2.10).

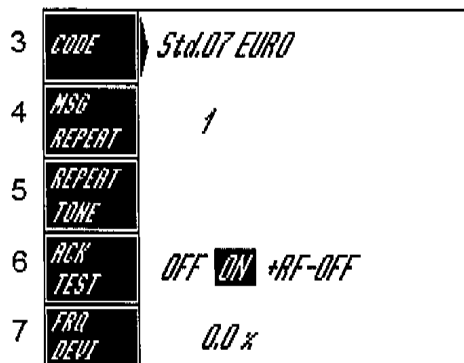

Fig. 2.5-4 CODE submenu 1

*) depending on model or option

Softkey 3: CODE (selection of standard)

One of 16 standards can be selected using `softkey 3/number/ENTER`. A number is assigned to each standard.

Section 2.4.4 explains the meaning of the numbers in more detail. Two standards are described below because of their special feature.

Standard 15 for CDCSS coding or standard 16 for ATIS coding can be selected using the CODE softkey under function CODE in submenu 1, the latter requiring option CMS-B27. The only key used for the two standards in submenu 1 is the CODE softkey.

a) Function CODE CDCSS (Standard 15)

After activating softkey CODE, a 3-digit octal number which has to correspond to one of the 83 CDCSS codes can be entered. Prefix # has to be put in front of the octal number for inverted codes. Acknowledgement using the ENTER key effects a cyclic transmission of the CDCSS code via modulation generator 2 whose deviation can be selected as already known.

Pressing key CLEAR effects the generation of the turn-off code and the subsequent cutting off of the RF power (cf. submenu 2).

b) Function CODE ATIS (Standard 16): Requires Option CMS-B27 *)

After the CODE softkey has been activated, a 10-digit decimal number can be entered as an ATIS self-identification code. The entire ATIS message including error check signal is added to the above entry.

Pressing the ENTER key effects a single transmission of the ATIS message as an FSK modulation via the RF output, with the modulation index of 2 rad stipulated in the ATIS regulation being preselected automatically (independently of the value displayed).

For further explanations on standards 0 to 16 refer to Section 2.10.

Softkey 4: MSG REPEAT (Message Repeat)

`softkey 4/number/ENTER` is used to define how often the message is to be repeated. A value of 1 corresponds to the normal setting.

Larger numbers are entered if the response sensitivity of a radiotelephone to the telegram is to be determined. The RF level is then varied whilst the telegrams are sent until the receiver responds. Uninterrupted repetition of telegrams can be stopped by pressing the OFF key.

This is entered using `softkey 7/number` with or without `sign/ENTER`. The number corresponds to the frequency deviation in %.

Softkey 5: REPEAT TONE

The digit repeat function can be switched on or off using softkey 5.

With the digit repeat switched on, the second digit of a double digit is replaced by the repeat digit (E). With the digit repeat switched off, the second digit is repeated, which usually leads to an extra-long tone. The digit repeat of the decoder is coupled to this function (see Section 2.4.4).

Softkey 6: ACK TEST (acknowledgement test)

The automatic sequence "Acknowledgement call test" is started by pressing softkey 6; it is then started by activating softkey 4 CODE in the main menu RX-test. The sequence comprises the following steps:

1. Transmission of previously selected tone sequence.
2. Following the last tone in the sequence, the CMS is transferred to the transmitter test with all settings belonging to this test. Note in particular that the transmitter test operating frequency must still be set in the transmitter test to the frequency at which the reply from the radiotelephone is expected. In the position + RF OFF the RF-carrier of the CMS is additionally switched off after the last tone of the tone sequence, since some radiotelephones only reply without input signal.
3. The result of the acknowledgement test is the decoded tone sequence and the modulation.

Softkey 7: FRQ DEVI (frequency deviation)

In order to carry out frequency limit tests on the selective call evaluator, a relative frequency deviation of up to $\pm 10\%$ can be selected uniformly for all tones in the sequence.

CODE Function: Submenu 2

| | | |
|---|-------------------|-------------|
| 3 | NO SPEC LENGTH | 1 100 ms |
| 4 | OTHER LENGTH | 100 ms |
| 5 | DIGIT PAUSE | 0 ms |
| 6 | MSG PAUSE | 200 ms |
| 7 | RESET STD | |

Fig. 2.5-5 CODE submenu 2

Softkey 3 is assigned two functions. The SHIFT key is used for selecting first or second function.

Softkey 3: NO SPC

This function is used to select a tone of the selective-call sequence which is to be subjected to extended tone duration. This is normally the first tone of extended duration compared to the other tones. The entry is made using `Softkey 3 (NO SPC)/number (tone duration in ms)/ENTER`.

Softkey 3: LENGTH

Certain selective call principles can also address receivers with sleep mode. An extended tone in the selective call sequence then bridges the "sleeping pause" of the receiver. The duration of the first tone can be set using `softkey 3 LENGTH/number/ENTER` and corresponds to the number in ms.

Softkey 4: OTHER LENGTH (duration of other tones)

The duration (in ms) of the following tones can be uniformly set by entering `softkey 4/number/ENTER`.

Softkey 5: DIGIT PAUSE

Pauses can be defined between the tones (in ms) uniformly for a tone sequence by entering `softkey/5/ number/ENTER`.

The tone and pause durations need only be selected if values different from the standard are required. These values are components of the standard and can be assigned to the individual standards in the "Definition menu for tones" (Section 2.10).

Softkey 6: MSG PAUSE (message pause)

The pause (in ms) between two messages is defined by entering `softkey 6/number/ENTER`.

Softkey 7: RESET STD

The original parameters, modified by softkeys 3 to 6 can be reset using this softkey.

Submenu 2 has no significance for standard 16 (ATIS).

For standard 15 submenu 2 has a modified appearance:

CDCSS: Submenu 2
Softkey TRN-OFF-CODE can be used to set the length of the turn-off code effecting the turn off of the squelch function of the test object connected.

Softkey TRANSM END serves to set the time between the start of the turn-off code and the cutting off of the transmitter.

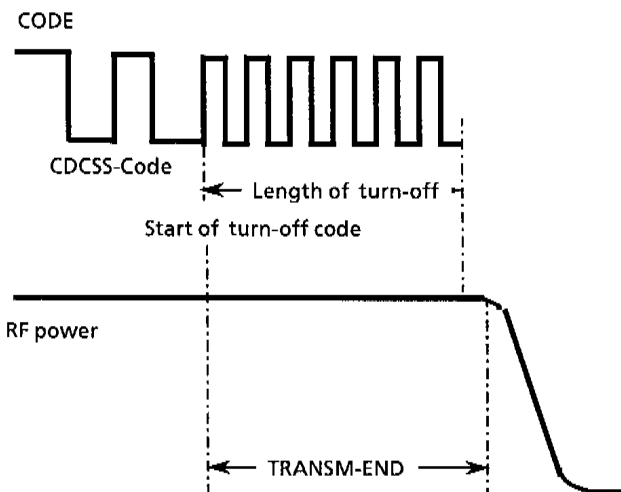

Fig. 2.5-6 Time diagram

COUNT Function

This function is used to determine the frequency of the signal connected to the AF/SCOPE connector 24.

A reference frequency can be entered using `softkey 4/REF/number/dimension OR ENTER` and is always subtracted from the absolute counter result. The currently measured frequency is set as the reference frequency using `softkey 4/REF/dimension OR ENTER`.

COUNT Function: Submenu

The COUNT function has a submenu which is output in the display field next to softkey 5.

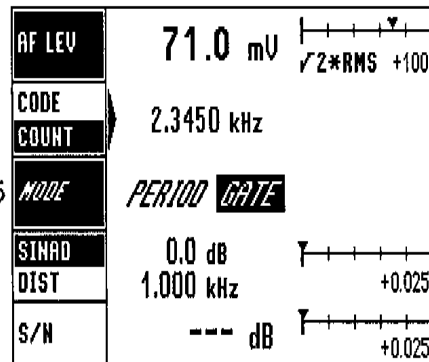

Fig. 2.5-7 COUNT submenu

Softkey 5: MODE (operating mode and resolution of counter)

Selection between 2 modes is possible:

1. Period counting
2. Gate time counting 1 Hz

Period counting has a resolution of 0.1 Hz up to 100 kHz; the resolution is 1 Hz at frequencies exceeding this value. Period counting is fast but requires a signal without noise.

Gate time counting is less sensitive to noisy signals.

2.5.5 Filter Selection

FILTER Function

Various AF filters can be switched on or off using `softkey 5/ON` or `OFF`. The AF filters and their characteristic frequencies can be selected in two submenus.

FILTER Function: Submenu 1

The FILTER function has two submenus. The first submenu is output in the display fields next to softkeys 4 and 7, the second submenu in the fields next to softkeys 4 to 5.

The operation of softkeys 4 to 7 is analogous to that described in Section 2.4.5.

The FILTER submenu 2 is called by pressing the MENU ↓ (DOWN) key.

FILTER Function: Submenu 2

The operation of softkeys 4 and 5 is analogous to that described in 2.4.5 for the transmitter test. Softkeys 6 and 7 are however not displayed.

2.5.6 SINAD and Distortion Measurements

Softkey 6 is assigned two functions:

SINAD (S/N measurement)
DIST (distortion measurement)

The SHIFT key is used to select either the first or second function.

SINAD/DIST Function

The two measurements are performed using the same method. The result is displayed in dB for SINAD and in % for distortion.

Test frequency

The test frequency is defined via `softkey 6/number/dimension Hz` or `kHz`. It is possible to select in the submenu whether the modulation generator is to be set to this frequency or not.

Automatic search routine

The automatic search routine is started using `softkey 6/number/dimension % (distortion)` or `dB (SINAD)`. The routine is run as follows: The RF level is modified until the measured value corresponding to the number is reached. The RF level obtained at the end of the search routine corresponds to the receiver sensitivity. The search routine can be aborted by pressing softkey 6.

The full-scale value can also be influenced in the analog display for the SINAD or DIST measurement.

When `softkey 6/RANGE/%` or `dB` or `ENTER` are pressed, the currently measured value is used for defining the full-scale value.

When `softkey 6/RANGE/number/%` or `dB` or `ENTER` are pressed, the entered number is used for defining the full-scale value.

Tolerance markers can be set in the analog display using the same syntax: `softkey 6/TOL/number/%` or `dB` or `ENTER`.

SINAD/ DIST Function: Submenu

A submenu is available for the SINAD/DIST function, which is output in the display fields next to softkeys 3 to 5 and 7. Softkey 6 remains assigned to the main menu.

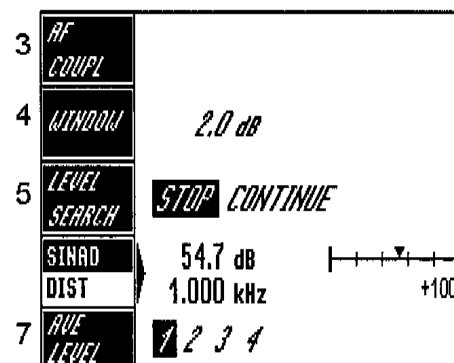

Fig. 2.5-8 SINAD/DIST submenu

Softkey 3: AF COUPL (test frequency)

Softkey 3 can be used to define whether the test frequency selected for the distortion is also to define the frequency of the modulation generator 1 or not.

Application:

Coupling usually has advantages. The modulation generator supplies the signal, which is to be measured by the distortion meter or the SINAD meter following the device-under-test. However, if the radio receiver has a scrambler, the coupling is switched off and the modulation generator signal is set independently of the distortion/SINAD test frequency.

Softkey 4: WINDOW (abort window)

Softkey 4 can be used to define a criterion for aborting the automatic search routine. The range around the target value to be measured is determined by entering `softkey 4/number/dB` or `%`. The entered number defines the magnitude in % or dB around the target value as the abort window. When a measured value from this range is reached in the search routine for the first time, the search routine is aborted.

Softkey 5: LEVEL SEARCH (stop/continue search routine)

Softkey 5 selects whether the RF level variation is to be stopped when the abort window is reached or not.

Application:

If the receiver sensitivity is to be determined by a measurement, the "stop" position is selected. The "continue" position is selected if the receiver sensitivity is to be set to a maximum during the search routine.

Softkey 7: AVE LEVEL (averaging factors)

Four averaging factors are available to be selected via softkey 7.

- 1: One measurement determines the result.
- 2: The result is the average of two measurements.

3: The result is the average of three measurements.

4: The result is the average of four measurements.

Each single measurement corresponds to the average of 5 AD values.

In IEC-bus operation, the single measurements are repeated with large changes in signal level following a delay time.

2.5.7 S/N Measurement

S/N Function

The S/N measurement is very similar to the distortion or SINAD measurement except that the wanted modulation is switched off during the noise measurement and not eliminated by a filter.

Dimension

The S/N ratio is displayed either in % or dB by entering `softkey 7/dimension %` or `dB`.

The full-scale value can also be influenced in the analog display for the S/N measurement.

The currently measured value is used to define the full-scale value by entering `softkey 7/RANGE/%` or `dB` or `ENTER`.

The number is used to define the full-scale value by entering `softkey 7/RANGE/number/%` or `dB` or `ENTER`.

Tolerance markers can be set in the analog display with the same syntax: `softkey 7/TOL/number/%` or `dB` or `ENTER`.

Automatic search routine

An automatic search routine is initiated via `softkey 7/number/dimension %` or `dB`. The routine is executed as follows:

The RF level is modified until the measured value corresponding to the number is reached. The RF level at the end of the search routine corresponds to the receiver sensitivity.

The search routine can be aborted by pressing softkey 7.

S/N Function: Submenu

A submenu is available for the S/N function, which is output in the display fields next to softkeys 3 to 7.

| | | |
|---|--------------|---------------|
| 3 | GEN 2 | UNUSED USED |
| 4 | EXT | UNUSED USED |
| 5 | WINDOW | 2.0 dB |
| 6 | LEVEL SEARCH | STOP CONTINUE |
| 7 | AVE LEVEL | 1 2 3 4 |

Fig. 2.5-9 S/N submenu

Softkey 3: GEN2 (modulation generator 2)

The modulation is switched on and off by modulation generator 1. Softkey 3 can be used to select whether the modulation generator 2 is to follow this rhythm or not.

Softkey 4: EXT (external modulation)

Softkey 4 can be used in the same manner as described above to select whether the external modulation applied to the MOD EXT connector is to follow this rhythm or not.

Softkey 5: WINDOW (abort window)

Softkey 5 can be used to define a criterion for aborting the automatic search routine. The range around the target value to be measured is determined by entering `softkey 5/number/dB` or `%`. The entered number determines the magnitude in % or dB around the target value as the abort window. When a measured value from this range is reached in the search routine for the first time, the search routine is aborted.

Softkey 6: LEVEL SEARCH (stop/continue search routine)

Softkey 6 selects whether the RF level variation is to be stopped when the abort window is reached or not.

Application:

If the receiver sensitivity is to be determined by a measurement, the "stop" position is selected. The "continue" position is selected if the receiver sensitivity is to be set to a maximum during the search routine.

Softkey 7: AVE LEVEL (averaging factors)

Four averaging factors can be selected using softkey 7:

- 1: The result is the average of one signal measurement and two noise measurements.
- 2: The result is the average of one signal measurement and three noise measurements.
- 3: The result is the average of two signal measurements and four noise measurements.
- 4: The result is the average of two signal measurements and five noise measurements.

Each single measurement corresponds to the average of five AD measurements.

In local and IEC-bus mode, the single measurements are repeated following a delay time in case of large changes in signal level. (Different S/N ratios (measurement times) may result.)

2.5.8 Lock

LOCK Function

Softkey 8 is assigned the function of a simple changeover key.

If the LOCK mode is active, TX test can only be reached by operation in the RX test. With the LOCK function deactivated the switchover from RX test to TX test is only possible by applying an RF power to the RF IN/OUT socket 29.

The RX test is automatically actuated again by an RF voltage drop. This return to RX test can, however, be eliminated when switching to the TX test via keys or by calling a submenu in the TX test.

Application:

The LOCK status is used if discontinuous transmitter tests are carried out, e.g. power pulses of limited duration with superimposed modulated data messages. The LOCK function prevents the CMS from returning to the receiver test following each pulse. A typical example is a acknowledgement call. The LOCK function is switched on automatically in this case and with certain other measurements such as e.g. cellular radio.

2.5.9 Modulation Generators

Softkey 9 is assigned all functions of the first modulation generator, softkey 10 those of the second modulation generator. Each softkey is assigned the frequency as first function and the modulation as the second. Switching between the two functions is possible by entering SHIFT/softkey 9 OR 10.

AF1/AF2 Function

The frequency is entered using softkey 9 OR 10/number/dimension OR ENTER. The modulation generator is switched off by entering softkey 9 OR 10/OFF. This switch-off function for the level when making a frequency entry has the following function:

The modulation of tone sequences generated naturally by modulation generators are set using the MOD function. If the modulation generator is not switched off using the above-mentioned method, the valid continuous tone is output before and after the tone sequence. The modulation generator can be switched on again using softkey 9 OR 10/ON.

Variation function

The variation increment for the VAR spinwheel can be entered using softkey 9 OR 10/VAR/number/dimension OR ENTER. In contrast to usual operation, VAR/0/ENTER does not set the minimum increment but leads to variation with the fixed frequency series (see VAR function, Section 2.3.2.2.1 and definition menu for tones, Section 2.10).

Reference function

The selected frequency is defined to be the reference by entering REF/number/dimension OR ENTER. The set frequencies are to be understood as a difference from the reference frequency (see REF function, Section 2.3.2.2.1).

MOD1/MOD2 Function

The modulation is entered using softkey 9/number/dimension OR ENTER. The operating mode of the instrument is determined by the dimension selected for the 1st modulation generator.

Selection of the dimension % sets the CMS to AM mode, selection of the dimension kHz or Hz to FM mode and selection of the dimension rad to φM mode.

The modulation mode of the 2nd modulation generator follows that of the 1st (dual-tone modulation).

(An external modulation source is used for dual-tone modulation.)

The modulation can be switched off using softkey 9 OR 10/OFF, and the previously valid modulation can be switched on again using softkey 9 OR 10/ON.

MOD1/MOD2 Function: Submenu

There is a submenu for the MOD1/MOD2 function which is output in the fields in the display next to softkeys 11 to 14. This submenu can be selected by means of softkey 9 or softkey 10.

| | | | |
|--------------|---|-------------|----|
| 1.000 kHz | 0 | MOD EXT | 11 |
| | | MOD OFF | 12 |
| PK --- V | | MOD EXT CAL | 13 |
| PK 1.41421 V | | MOD EXT REF | 14 |
| DC AC | | RM-COURL | 15 |

Fig. 2.5-10 MOD1/MOD2 submenu

Softkey 11: MOD EXT (external modulation)

An external modulation signal can be connected to the MOD EXT connector and can be entered using softkey 11/number/dimension or ENTER. Modulation mode AM (multi-tone) is possible via the external input if the instrument is in AM mode. The dimensions used are %, kHz or Hz.

Further FM modulation (multi-tone) is possible via the external input if the instrument is in FM mode.

**Softkey 12: MOD OFF
(switching off modulation)**

All modulation is switched off by pressing softkey 12; the modulation modes are retained.

**Softkey 13: MOD EXT CAL
(external calibration)**

Softkey 13 should be pressed if the voltage applied to the MOD EXT connector is unknown. The instrument then measures this voltage (output in the display) and takes it into account when setting the modulation. (Subsequent changes in voltage are not taken into account.)

**Softkey 14: MOD EXT REF
(input of modulation voltage)**

Softkey 14/number/dimension or ENTER can be used to inform the instrument of the voltage applied to the MOD EXT connector which is to be used as the basis for the external modulation setting. The number corresponds to the peak voltage; input ranges between 50 mV and 2 V with DC coupling and between 5 mV and 2 V with AC coupling can be taken into account, otherwise a message is output in the display.

Softkey 15: AM-COUP

This softkey is used to select AC or DC coupling with external AM modulation. DC coupling is selected when the RF signal amplitude is to be varied using an external DC voltage, e.g. for simulation of a fading signal.

2.5.10 Oscilloscope / DC Measurement

Operation and use of the oscilloscope and the DC measurement feature are analogous to that as described in Section 2.4.10 for the transmitter test.

The settling measurement *) can however not be called in the RX test menu.

*) depending on model or option

2.6 Duplex Test (DX-Test) *)

| | | | | | |
|---|---------|----------------------------|----------------------------|---------|----|
| 0 | RX-TEST | DX-TEST CMS - Local | | TX-TEST | 8 |
| 1 | SET RF | 100.00000 MHz | 123.456831 MHz | COUNT | 9 |
| 2 | RF LEV | 0.170 μ V | 31.6 dBm | POWER | 10 |
| 3 | AF LEV | 0.199 V | 13.08 kHz | DEMOD | 11 |
| 4 | MOD 1 | 2.800 kHz | 1.0000 kHz | AF 1 | 12 |
| | MOD 2 | 0.000 kHz | 1.00 mV | LEV 1 | |
| 5 | FILTER | OFF | 0.3000 kHz | AF 2 | 13 |
| | | | 0.00 mV | LEV 2 | |
| 6 | SINAD | 54.6 dB | NARROW WIDE | IF | 14 |
| | DIST | 1.000 kHz | | INPUT 1 | |
| 7 | S/N | --- dB | INT: 0 dB EXT-ATT: 15.4 dB | INPUT 2 | 15 |
| | | | 0.0 dB | | |

Fig. 2.6-1 Main menu DX test

Starting with the main menu of the selection menu, the main menu DX-TEST (duplex test) can be entered by pressing the softkey DX-TEST.

This menu contains all controls required to carry out a normal duplex test. Almost every function offers submenus. These provide controls for duplex test functions that are required less often.

Softkey 0 may be used to branch directly to the main menu of the receiver test (RX-TEST), softkey 8 to the main menu of the transmitter test (TX-TEST).

The duplex test is a combination of the most important transmitter and receiver test functions. The following sections serve to provide an overview of the interdependencies, e. g. the effect of the transmit power on the receiver sensitivity.

2.6.1 RF Frequency Setting

SET RF Function

This function is described in the RX test (see Section 2.5.1).

2.6.3 AF Level Setting

AF LEV Function

This function is described in the RX test (see Section 2.5.3).

2.6.2 RF Level Setting

RF LEV Function

This function is described in the RX test (see Section 2.5.2).

*) depending on model or option

2.6.4 Modulation

Softkey 4 is used to select the modulation generators. The active modulation generator is displayed in inverse video. The SHIFT key allows to switch between modulation generator 1 and 2.

MOD1/MOD2 Function

The modulation is entered using `softkey 4/number/dimension` or `ENTER`. The operating mode of the instrument is determined by the dimension selected for the 1st modulation generator.

Selection of the dimension % sets the CMS to AM mode, selection of the dimension kHz or Hz to FM mode and selection of the dimension rad to ϕ M mode.

The modulation mode of the 2nd modulation generator follows that of the 1st (dual-tone modulation). Modulation 2 is therefore simply acknowledged with `ENTER`.

The modulation can be switched off using `softkey 4/OFF`, and the previously valid modulation can be switched on again using `softkey 4/ON`.

Variation function (MOD1 only)

The variation increment for the spinwheel VAR is entered by means of `softkey 4/VAR/number/dimension` or `ENTER`.

Reference function (MOD1 only)

The selected modulation can be chosen as reference using `softkey 4/REF/number/dimension` or `ENTER`.

2.6.5 Filter Selection

FILTER Function

Various AF filters can be switched on or off using `softkey 5/ON` or `OFF`. The AF filters and their characteristic frequencies can be selected in two submenus.

The filters are switched as in the RX test. Their operation is exactly the same as in the RX test and, apart from differences with softkeys 6 and 7, explained in submenu 2 of Section 2.4.5 (TX test).

FILTER Function: Submenu 1

The FILTER function has two submenus. The first submenu is output in the display fields next to softkeys 4 and 7, the second submenu in the fields next to softkeys 4 to 5.

The operation of softkeys 4 to 7 is analogous to that described in Section 2.4.5.

FILTER Function: Submenu 2

The FILTER submenu 2 is called by pressing the `MENU ↓ (DOWN)` key.

The operation of softkeys 4 and 5 is analogous to that described in 2.4.5 for the transmitter test. Softkeys 6 and 7 are however not displayed.

2.6.6 SINAD and Distortion Measurements

Softkey 6 is assigned two functions:

SINAD (S/N measurement)
DIST (distortion measurement)

The SHIFT key is used to select either the first or second function.

SINAD/DIST Function

The two measurements are performed using the same method. The result is displayed in dB for SINAD and in % for distortion.

Test frequency

The test frequency is defined via `softkey 6/number/dimension Hz or kHz`. It is possible to select in the submenu whether the modulation generator is to be set to this frequency or not.

Automatic search routine

The automatic search routine is started using `softkey 6/number/dimension % (distortion) or dB (SINAD)`. The routine is run as follows: The RF level is modified until the measured value corresponding to the number is reached. The RF level obtained at the end of the search routine corresponds to the receiver sensitivity. The search routine can be aborted by pressing softkey 6.

The full-scale value can also be influenced in the analog display for the SINAD or DIST measurement.

When `softkey 6/RANGE/% or dB or ENTER` are pressed, the currently measured value is used for defining the full-scale value.

When `softkey 6/RANGE/number/% or dB or ENTER` are pressed, the entered number is used for defining the full-scale value.

Tolerance markers can be set in the analog display using the same syntax: `softkey 6/TOL/number/% or dB or ENTER`.

SINAD/ DIST Function: Submenu

A submenu is available for the SINAD/DIST function, which is output in the display fields next to softkeys 3 to 5 and 7. Softkey 6 remains assigned to the main menu.

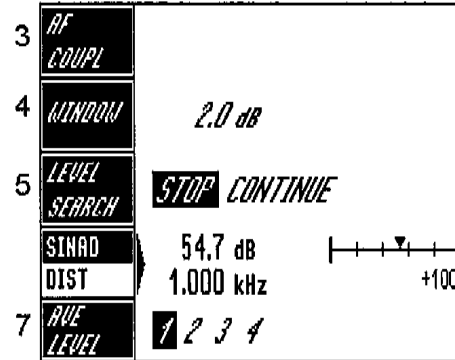

Fig. 2.6-2 SINAD/DIST submenu

Softkey 3: AF COUPL (test frequency)

Softkey 3 can be used to define whether the test frequency selected for the distortion is also to define the frequency of the modulation generator 1 or not.

Application:

Coupling usually has advantages. The modulation generator supplies the signal, which is to be measured by the distortion meter or the SINAD meter following the device-under-test. However, if the radio receiver has a scrambler, the coupling is switched off and the modulation generator signal is set independently of the distortion/SINAD test frequency.

Softkey 4: WINDOW (abort window)

Softkey 4 can be used to define a criterion for aborting the automatic search routine. The range around the target value to be measured is determined by entering `softkey 4/number/dB or %`. The entered number defines the magnitude in % or dB around the target value as the abort window. When a measured value from this range is reached in the search routine for the first time, the search routine is aborted.

**Softkey 5: LEVEL SEARCH
(stop/continue search routine)**

Softkey 5 selects whether the RF level variation is to be stopped when the abort window is reached or not.

Application:

If the receiver sensitivity is to be determined by a measurement, the "stop" position is selected. The "continue" position is selected if the receiver sensitivity is to be set to a maximum during the search routine.

Softkey 7: AVE LEVEL (averaging factors)

Four averaging factors are available to be selected via softkey 7.

- 1: One measurement determines the result.
- 2: The result is the average of two measurements.
- 3: The result is the average of three measurements.
- 4: The result is the average of four measurements.

Each single measurement corresponds to the average of 5 AD values.

In IEC-bus operation, the single measurements are repeated with large changes in signal level following a delay time.

2.6.7 S/N Measurement

S/N Function

The S/N measurement is very similar to the distortion or SINAD measurement except that the wanted modulation is switched off during the noise measurement and not eliminated by a filter.

Dimension

The S/N ratio is displayed either in % or dB by entering `softkey 7/dimension % OR dB`.

The full-scale value can also be influenced in the analog display for the S/N measurement.

The currently measured value is used to define the full-scale value by entering `softkey 7/RANGE/%/ OR dB OR ENTER`.

The number is used to define the full-scale value by entering `softkey 7/RANGE/number/%/ OR dB OR ENTER`.

Tolerance markers can be set in the analog display with the same syntax: `softkey 7/TOL/number/% OR dB OR ENTER`.

Automatic search routine

An automatic search routine is initiated via `softkey 7/number/dimension % or dB`. The routine is executed as follows:

The RF level is modified until the measured value corresponding to the number is reached. The RF level at the end of the search routine corresponds to the receiver sensitivity.

The search routine can be aborted by pressing softkey 7.

S/N Function: Submenu

A submenu is available for the S/N function, which is output in the display fields next to softkeys 3 to 7.

| | | |
|---|--------------|---------------|
| 3 | GEN 2 | UNUSED USED |
| 4 | EXT | UNUSED USED |
| 5 | WINDOW | 2.0 dB |
| 6 | LEVEL SEARCH | STOP CONTINUE |
| 7 | AVE LEVEL | 1 2 3 4 |

Fig. 2.6-3 S/N submenu

Softkey 3: GEN2 (modulation generator 2)

The modulation is switched on and off by modulation generator 1. Softkey 3 can be used to select whether the modulation generator 2 is to follow this rhythm or not.

Softkey 4: EXT (external modulation)

Softkey 4 can be used in the same manner as described above to select whether the external modulation applied to the MOD EXT connector is to follow this rhythm or not.

Softkey 5: WINDOW (abort window)

Softkey 5 can be used to define a criterion for aborting the automatic search routine. The range around the target value to be measured is determined by entering `softkey 5/number/dB or %`. The entered number determines the magnitude in % or dB around the target value as the abort window. When a measured value from this range is reached in the search routine for the first time, the search routine is aborted.

Softkey 6: LEVEL SEARCH (stop/continue search routine)

Softkey 6 selects whether the RF level variation is to be stopped when the abort window is reached or not.

Application:

If the receiver sensitivity is to be determined by a measurement, the "stop" position is selected. The "continue" position is selected if the receiver sensitivity is to be set to a maximum during the search routine.

Softkey 7: AVE LEVEL (averaging factors)

Four averaging factors can be selected using softkey 7:

- 1: The result is the average of one signal measurement and two noise measurements.
- 2: The result is the average of one signal measurement and three noise measurements.

3: The result is the average of two signal measurements and four noise measurements.

4: The result is the average of two signal measurements and five noise measurements.

Each single measurement corresponds to the average of five AD measurements.

In local and IEC-bus mode, the single measurements are repeated following a delay time in case of large changes in signal level. (Different S/N ratios (measurement times) may result.)

2.6.8 RF Count Measurement

In the case of simple transmitter tests the instrument measures the transmitter frequency and sets the demodulators to this frequency. The receiver frequency of the instrument can also be preset if the device under test outputs several carrier frequencies (off-air measurement) or if the time for counting is insufficient for the demodulator to respond rapidly (demodulation of a fast acknowledgement).

COUNT Function

The count function is constantly active if the COUNT field is shown in inverted form.

The normal count function operates at the connector RF IN/OUT, depending on the model, it also operates at input 2.

The counter resolution can be set using the following input sequence: `softkey COUNT/number 1 or 10/terminating key Hz or ENTER`. Thus 1 Hz (slow) or 10 Hz (fast) is selected as the counter resolution.

The sensitivity of the RF counter in particular with frequencies < 1 MHz can be enhanced by switching the IF filter on.

Relative counting

There are two possibilities for selecting a reference frequency for relative counting.

Input of softkey `COUNT/REF/ENTER` declares the frequency just measured as the reference frequency; input of softkey `COUNT /REF /number /dimension` or `ENTER` declares the entered frequency as the reference frequency.

A sign in front of the result indicates that a relative frequency count is being carried out. Absolute frequency counting can be reselected by entering softkey `COUNT/REF/OFF`.

The dimensions MHz, kHz or Hz can be selected for direct or relative counting, e.g. softkey `COUNT/Hz`.

SET RF Function

The receiver frequency of the instrument is fixed using the SET RF function. It is not based on the counter result. If the SET RF function is not already active (displayed in inverted form), it can be activated by entering `SHIFT/softkey SET RF`. The CMS receiver frequency is usually entered and displayed as a frequency value.

The CMS receiver frequency is entered using softkey `SET RF/number/dimension` or `ENTER`.

The receiver frequency setting can be varied using the VAR function and the VAR spinwheel. The receiver frequency setting can also be relative.

The reference frequency can be entered using softkey `SET RF/REF/ENTER` if the current frequency is to become the reference frequency, or using the softkey `SET RF/REF/number/dimension` or `ENTER` if a frequency is to be set different from the reference frequency.

SET RF Function: Submenu

This submenu is identical with that assigned to softkey 1 and has been described in Section 2.4.1 (TX test).

2.6.9 Power Measurement

POWER Function

The broadband RF power measurement can only be performed at the RF IN/OUT socket. The dimensions of the measurement are W or dBm. Tolerance markers can be set on the analog bar for both W and dBm.

A logarithmic relative display based on a reference value can be selected.

Autorange or Range Hold can be selected on the analog display for the full-scale value.

2.6.10 Demodulation

DEMOD Function

The instrument is able to demodulate the transmitter signal according to AM, FM or ϕ M. One of the three demodulation modes is selected by the following input:

softkey `DEMOD/dimension`. FM demodulation is then used for the dimensions Hz and kHz, AM demodulation for % and ϕ M demodulation for rad.

Different weighting modes can be selected in the submenu. If peak weighting is selected, the positive and negative peaks are displayed at the same time. Tolerance markers and decision criteria such as e.g. branching in the autorun control program always refer to the positive peak value, however. The RMS weighting generates only one measured value.

Modulation sensitivity

The modulation sensitivity is integrated in a search routine, which varies the AF voltage of the modulation generator at the transmitter input until a predefined modulation depth, frequency deviation or phase deviation is attained as transmitter modulation.

The entry is made using:

Softkey `DEMOD/number/dimension`.

The number corresponds to the entered modulation value and the dimension to the demodulation mode of the CMS.

If the demodulation mode output in the display is to be retained, ENTER can be input instead of the dimension.

The analog display can be assigned a full-scale value depending on the measured value or a fixed full-scale value. The positive peak value applies if the fixed full-scale value is to be derived from the currently measured value.

Tolerance markers can be entered in the analog display. In the event of two measured values it is again the positive peak value which is used for the tolerance weighting.

2.6.11 Modulation Generators

Softkeys 12 and 13 are assigned the frequency as the first function and the level as the second function of the corresponding modulation generators. Switching between the two functions is possible using the SHIFT key.

AF 1/AF 2 Function

The frequency is entered using `softkey 12 or 13/number/dimension or ENTER`. The modulation generator is switched off by entering `softkey 12 or 13/OFF`, and switched on again using `softkey 12 or 13/ON`.

Variation function

The variation increment for the VAR spinwheel can be entered using `softkey 12 or 13/VAR/number/ dimension or ENTER`. In contrast to usual operation, `VAR/0/ENTER` does not set the minimum increment but leads to variation with the fixed frequency series (300 Hz, 600 Hz to 10 kHz).

Reference function

The selected frequency is defined to be the reference by entering `REF/number/dimension or ENTER`. The set frequencies must be understood as a difference from the reference frequency.

LEV1/LEV2 Function

Since the source impedance*) of the modulation generator is very low (approx. 2 Ω), the set level is to be understood as the EMF.

The modulation generator level is entered using `softkey 12 or 13/number/dimension or ENTER`. The power is referred to 600 Ω when the dimension dBm is selected. The level is switched off using `softkey 12 or 13/OFF`, and the previously valid level is switched on again using `softkey 12 or 13/ON`.

Variation function

The variation increment on the VAR spinwheel can be set using `softkey 12 or 13/VAR/number/ dimension or ENTER`.

Reference function

The variation increment for the level on the VAR spinwheel can be set using `softkey 12 or 13/REF/number/dimension or ENTER`.

2.6.12 IF Filter

The IF filter can be switched on and off using `softkey 14`. The IF bandwidth is limited to approx. 25 kHz by the NARROW filter. This improves the S/N ratio, especially when receiving small RF levels, but also results in a distortion at higher deviations and/or modulation frequencies.

2.6.13 Input Switchover

INPUT 1/INPUT 2 Function

The selected RF input (RF IN/OUT or RF 2) is shown in inverted form. The other input can be selected by entering `SHIFT/ softkey 15`. It is possible to inform the CMS of the attenuation value connected prior to the associated input. By entering `softkey 15/number/dB or ENTER` the CMS takes into account the entered attenuation for the level with RF measurement and setting.

*) depending on model or option

2.7 SSB Transmitter Test (TX-SSB)

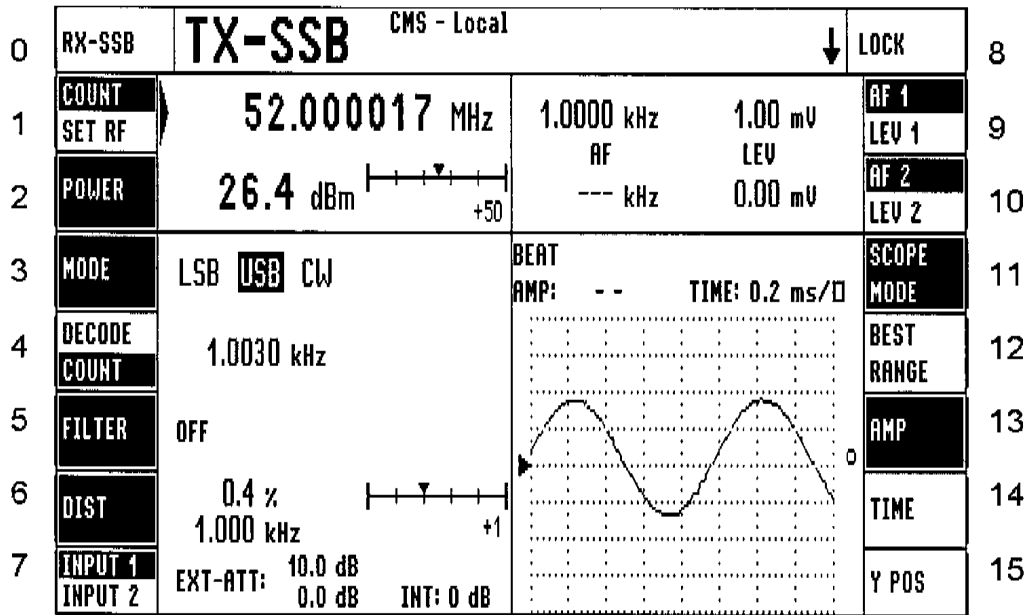

Fig. 2.7-1 Main menu TX-SSB

Starting with the main SSB menu accessible from the selection menu, the main menu TX-SSB (transmitter test) can be entered by pressing the softkey SSB. In SSB mode the CMS is switched to Beat mode and AM modulation permanently.

This menu contains all controls required to carry out a single side band transmitter test. Almost every function offers submenus. These provide controls for additional transmitter test functions that are required less often.

Softkey 0 may be used to branch to the receiver test (RX-SSB) main menu.

2.7.1 RF Count Measurement

With simple transmitter tests (only one RF frequency present), the instrument will show the frequency of the suppressed carrier. If the device under test outputs several strong RF frequencies, the receiver frequency should be preset by toggling to SET RF.

COUNT Function

The count function is constantly active if the COUNT field is shown in inverted form.

The normal count function only operates at the connector RF IN/OUT.

The count measurement is executed in BEAT mode only.

The carrier frequency value shown depends on

- the measured RF frequency
- the value of the chosen AF frequency and
- the setting of the ssb mode toggle (LSB, USB, CW).

In case of LSB and USB a suppressed carrier is assumed. Depending on the operating mode the following formulas apply:

$$\text{LSB (lower side band): } F_{sc} = F_m + F_{af}$$

$$\text{USB (upper side band): } F_{sc} = F_m - F_{af}$$

$$\text{CW (continuous wave): } F_c = F_m$$

with F_{sc} , F_c being the value of the (suppressed) carrier, F_m the measured RF frequency. F_{af} represents the AF generator frequency output by CMS (please refer to description of softkey 9 or 10 for further details).

In case AF1 and 2 are active simultaneously, a warning is issued; the value for F_{af} will correspond to AF1 in that case.

The local oscillator is set to F_{sc} in case of LSB and USB. In continuous wave mode, however, the LO frequency is as follows:

$$F_{lo} = F_m - ITF$$

where ITF is the international telegraph standard frequency of 800 Hz.

The counter resolution can be set using the following input sequence: `softkey COUNT/number 1 to 10/terminating key Hz or ENTER`. Thus 1 Hz (slow) or 10 Hz (fast) is selected as the counter resolution.

Relative counting

There are two possibilities for selecting a reference frequency for relative counting.

Input of `softkey COUNT/REF/ENTER` declares the frequency just measured as the reference frequency; input of `softkey COUNT /REF /number /unit key or ENTER` declares the entered frequency as the reference frequency.

A sign in front of the result indicates that a relative frequency count is being carried out. Absolute frequency counting can be reselected by entering `softkey COUNT/REF/OFF`.

The dimensions MHz, kHz or Hz can be selected for direct or relative counting, e.g. `softkey COUNT/Hz`.

The normal count function comprises a coarse direct broadband count and a subsequent exact AF count.

Softkey 3: FRQ PRESET (IF count)

This setting is of no consequence in SSB mode.

Softkey 4: DIRECT COUNT

Switch-on: `Softkey 4/number 100 or 1000/ dimension Hz or ENTER`. Direct counting is carried out with a resolution of 100 or 1000 Hz.

Switch-off: `Softkey 4/OFF`

Softkey 5: FRQ TRANS (transfer function)

Actuating this softkey once transfers the measured frequency as CMS receiver frequency.

In the main menu, this action switches from the COUNT function to SET RF.

Application:

Softkey 5 facilitates operation with regard to entry of multi-digit or unknown transmitter frequencies as CMS receiver frequency.

COUNT Function: Submenu

The function COUNT has a submenu which is output in the display fields next to softkeys 3, 4 and 5.

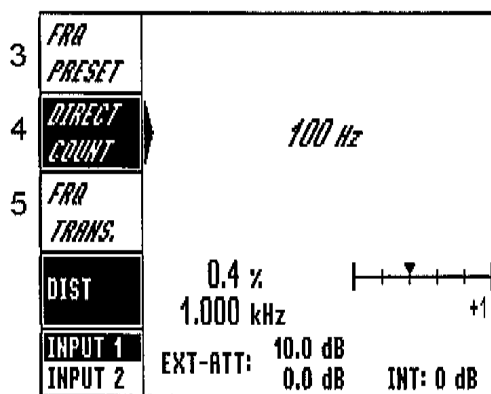

Fig. 2.7-2 COUNT submenu

SET RF Function

The receiver frequency of the instrument is fixed using the SET RF function. It is not based on the counter result. If the SET RF function is not already active (displayed in inverted form), it can be activated by entering `SHIFT/softkey SET RF`. The CMS receiver frequency is usually entered and displayed as a frequency value using softkey `SET RF/number/dimension OR ENTER`.

The receiver frequency setting can be varied using the VAR function and the VAR spinwheel. The receiver frequency setting can also be relative.

The reference frequency can be entered using softkey `SET RF/REF/ENTER` if the current frequency is to become the reference frequency, or using the softkey `SET RF/REF/number/dimension OR ENTER` if a reference frequency is to be set to a different value.

SET RF Function: Submenu

This submenu has been described in the TX test section of this manual. Please refer to section 2.4.1.

2.7.2 Power Measurement

POWER Function

The broadband RF power measurement can only be performed at the RF IN/OUT socket; the selective RF power measurement can also be carried out at the RF IN 2 socket (input 2). The dimensions of the broadband RF power measurement are W or dBm, those of the selective RF power measurement are mV, W, dB μ V or dBm.

A logarithmic relative display based on a reference value may be selected. Tolerance markers can be set on the analog bar for the dimensions mentioned above. Autorange or Range Hold for the full-scale value can be selected on the analog display.

POWER Function: Submenu

This submenu has been described in the TX test section of this manual. Please refer to section 2.4.2.

2.7.3 MODE Function

MODE Function

The DUT's SSB transmission mode is set using softkey 3. Three different settings may be selected:

- LSB (Lower Side Band)
- USB (Upper Side Band)
- CW (Continuous Wave).

In order to correctly measure the frequency of the suppressed carrier, the transmission mode of the DUT must be known to the CMS (RF measurement: COUNT function).

2.7.4 AF Measurement

This mode is described in the TX test (see Section 2.4.4).

COUNT Function

The frequency of the demodulated signal or the beat signal is counted by pressing softkey 4.

A relative measurement can be made in two different ways:

- The currently measured frequency is selected as the reference frequency by entering softkey `4/REF/ENTER`.
- An arbitrary frequency value is selected as the reference frequency by entering `REF/number/dimension OR ENTER`.

The relative result is the difference to the reference frequency. Relative measurements are identified by a sign in front of the result.

COUNT Function: Submenu

The COUNT function has a submenu which is output in the field of the display next to softkey 6.

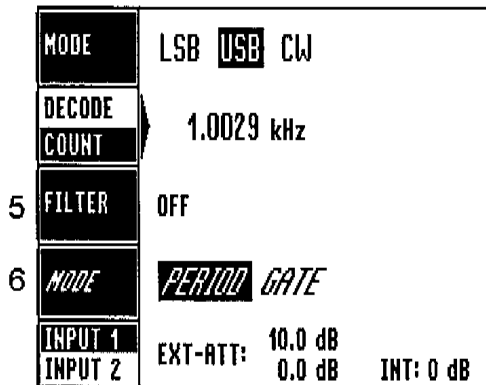

Fig. 2.7-3 COUNT submenu

Softkey 6: MODE (operating mode and resolution of counter)

There are two alternatives:

- Period counting
- Gate time counting

Period counting has a resolution of 0.1 Hz up to 100 kHz; the resolution is 1 Hz at frequencies above this value. Period counting is fast but requires a signal without noise.

Gate time counting is slower but less sensitive to noisy signals.

2.7.5 Filter Selection

FILTER Function

Various AF filters can be switched on or off using softkey 5/ON or OFF. The AF filters and their characteristic frequencies can be selected in two submenus.

FILTER Function: Submenu 1

This submenu has been described in the TX test section of this manual. Please refer to section 2.4.5.

*) depending on model or option

FILTER Function: Submenu 2

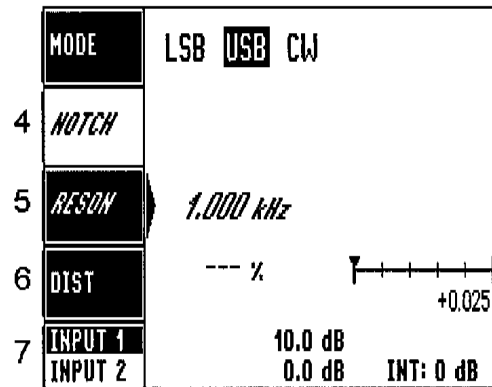

Fig. 2.7-4 FILTER submenu 2

Softkey 4: NOTCH (notch filter)

The notch filter is switched on using softkey 4/ON and off using softkey 4/OFF.

Stop frequency of notch filter:

The stop frequency of the notch filter is also selected using softkey 4. The entry is made using softkey 4/number/dimension OF ENTER.

Since the frequencies cannot always be set exactly as required, the frequency actually set is output in the display.

Softkey 5: RESON (resonance filter)

The resonance filter is switched on using softkey 5/ON and off using softkey 5/OFF.

Resonance frequency of resonance filter:

Softkey 5 is used to select the resonance frequency of the filter. The entry is made using softkey 5/number/dimension OF ENTER. The actually set frequency is displayed as with the notch filter.

Filter combinations*)

For better understanding all filters can be envisaged as a series connection of three filter groups:

- Highpass filter - lowpass filter
- Psophometric filter - external filter
- Notch filter - resonance filter

Highpass and lowpass filters can be combined independently into four different filter configurations.

The psophometric filter and the external filter cannot be combined, the same applies to the notch filter and the resonance filter. Since the notch filter is used for distortion and SINAD measurements, the last filter group cannot be used for evaluation during a distortion or SINAD measurement.

Notch filter and resonance filter are also being switched off when quitting or selecting RX-test and TX-test, since in this case SINAD or DIST measurements automatically continue to run.

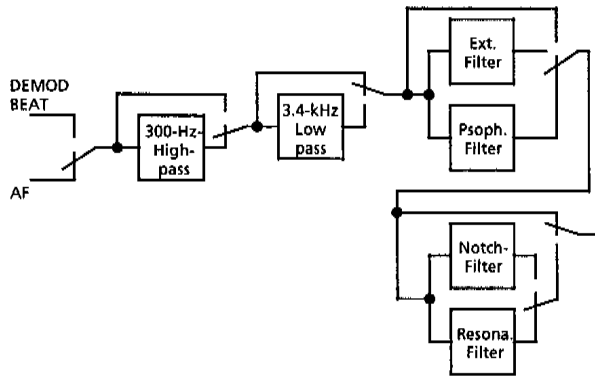

Fig. 2.7-5 Signal paths

2.7.6 Distortion Measurement

DIST Function

This function has been described in the TX test section of this manual. Please refer to section 2.4.6.

2.7.7 Input Switchover

INPUT 1/INPUT 2 Function

This function has been described in the TX test section of this manual. Please refer to section 2.4.7.

2.7.8 Lock

LOCK Function

This function has been described in the TX test section of this manual. Please refer to section 2.4.8.

2.7.9 Modulation Generators

AF1/AF2 Function

This function has been described in the TX test section of this manual. Please refer to section 2.4.9.

LEV1/LEV2 Function

This function has been described in the TX test section of this manual. Please refer to section 2.4.9.

2.7.10 Oscilloscope Settling Measurement *)

SCOPE MODE Function

This function has been described in the TX test section of this manual. Please refer to section 2.4.10. Settling measurement is not possible in SSB mode*).

*) depending on model or option

2.8 SSB Receiver Test (RX-SSB)

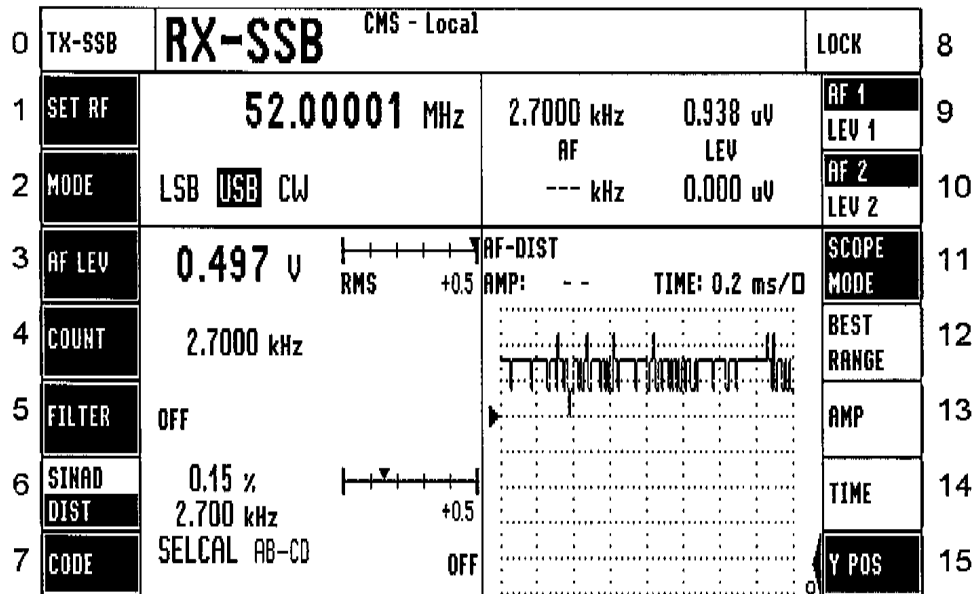

Fig. 2.8-1 Main menu RX-SSB

The main menu RX-SSB (receiver test) can be accessed by pressing the softkey RX-SSB in the upper left corner of the SSB transmitter test menu TX-SSB.

It contains all controls required to carry out a single side band receiver test. Almost every function contains submenus. These contain controls which can be used for more seldom receiver test functions.

Softkey 0 may be used to branch to the main menu for the transmitter test (TX-SSB).

In SSB mode, single or two-tone modulation is permissible. The kind of modulation depends on the number of AF generators used. To switch off an AF generator, press the OFF key after selecting the frequency of either AF1 or AF2 with the active cursor.

Note: Since for SSB a suppressed RF carrier is simulated, the RF level is set by means of softkeys 9 and 10, i. e. via the modulation.

Input of LEV1/OFF or LEV2/OFF has no influence on single/two-tone modulation.

a) Single tone

In case modulation is supplied by a single tone, complete carrier and residual sideband suppression is employed.

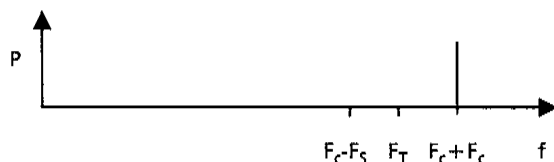

Fig. 2.8-2

Example:

USB mode (Upper Side Band): Complete absence of carrier F_c and residual sideband $F_c - F_s$ (lower sideband in this example).

b) Two-tone

In case of two-tone modulation, CMS will not suppress the spurious spectral components. Instead, the carrier as well as the modulation signals will be offset by 10 kHz, respectively. As a result, unwanted spectral components will come to rest in a position further away from the side band under analysis and thus not influence measurement results.

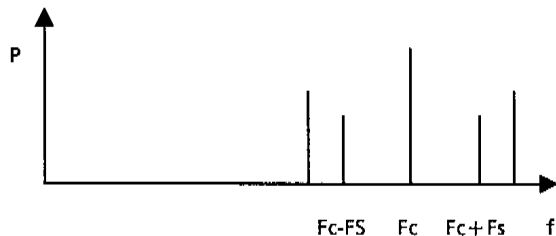

Fig. 2.8-3 Spectral components of an unmodified AM signal

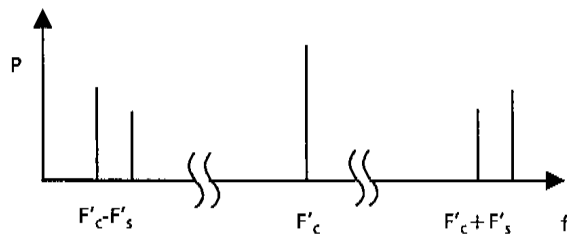

Fig. 2.8-4 Spectral components of the modified AM signal

Example: Mode USB, modified AM signal

$$F'_c = F_c - 10\text{kHz}$$

$$F'_s = F_s + 10\text{kHz}$$

By simultaneous modification of the carrier and unwanted sideband frequency, the wanted sideband frequency (USB in above example) remains unaffected while the disturbing components of the carrier and sideband are shifted far way away from their original frequencies and thus without affecting the DUT.

Note: Since the frequency offset of both carrier and unwanted sideband is achieved through the AF generator, the upper frequency limit of AF1 and AF2 is lowered to 20kHz. For the same reason, the frequency output at the MOD GEN socket is 10 kHz higher than displayed.

2.8.1 RF Frequency Setting

Please refer to corresponding section 2.5.1 (RX test).

2.8.2 Mode Function

MODE Function

The SSB transmission mode is set using the MODE function.

Three different settings may be selected:

- LSB (Lower Side Band)
- USB (Upper Side Band)
- CW (Continuous Wave).

With settings LSB and USB carrier and residual sideband will either not appear or be shifted a distant frequency range depending on type of modulation (single or two-tone).

In CW mode, the carrier that is typically suppressed in SSB will be transmitted; this carrier is defined by the frequency value supplied by the SET RF function and the RF level displayed next to softkey LEV1.

Both AF generators are switched off in CW mode, entry of AF frequency values is not possible.

2.8.3 AF Level Measurement

AF LEV Function

Please refer to corresponding section 2.5.3 (RX test).

2.8.4 AF Count Measurement

COUNT Function

This function has been described in the RX test section of this manual. Please refer to section 2.5.4.

2.8.5 Filter Selection

FILTER Function

Please refer to corresponding section 2.5.5 (RX test).

2.8.6 SINAD and Distortion Measurements

SINAD/DIST Function

Please refer to corresponding section 2.5.6 (RX test).

2.8.7 Code

CODE Function

An already stored selective call can be sent to the radiotelephone via the RF path using `softkey 7/ENTER`.

On entry into the SSB-RX menu code standard 13 (SELCAL) will be pre-selected.

A new call number can be entered and sent using `softkey 7/number/ENTER`. Depending on the tone standard selected, tone sequences of differing length may be issued; the keypad may assume different meanings (see RX test function CODE and section 2.11).

A tone sequence can be incorporated in a continuous tone of constant modulation or output as a modulation burst. Section 2.5.9 describes the setting of the two modes.

CODE Function: Submenu 1

Please refer to corresponding section 2.5.4 (RX test).

CODE Function: Submenu 2

This function has been described in the RX test section of this manual. Please refer to section 2.5.4.

2.8.8 Lock

LOCK Function

This function has been described in the RX test section of this manual. Please refer to section 2.5.8.

2.8.9 Modulation Generators

Softkey 9 is assigned all functions of the first modulation generator, softkey 10 those of the second modulation generator. Each softkey is assigned the frequency as first function and RF Level as the second. Switching between the two functions is possible by entering `SHIFT/softkey 9` or `10`.

AF1/AF2 Function

The frequency is entered using `softkey 9` or `10/number/dimension` or `ENTER`. The modulation generator is switched off by entering `softkey 9` or `10/OFF`. The modulation generator can be switched on again using `softkey 9` or `10/ON`.

Variation function

The variation increment for the VAR spinwheel can be entered using `softkey 9` or `10/VAR/number/dimension` or `ENTER`. In contrast to usual operation, `VAR/0/ENTER` does not set the minimum increment but leads to variation with the fixed frequency series (see VAR function, Section 2.3.2.2.1 and definition menu for tones, Section 2.10).

Reference function

The selected frequency is defined to be the reference by entering REF/number/dimension or ENTER. The set frequencies are to be understood as a difference from the reference frequency (see REF function, Section 2.3.2.2.1).

LEV1/LEV2 Function

Input of RF levels (determined by build-in modgen) may be accomplished through softkeys 9 or 10/number/unit or ENTER. If unit dBm is selected, power refers to 50 Ohms. Using softkey 9 or 10 followed by OFF will switch off the RF output assigned to LEV1 or LEV2, respectively. Softkey 9 or 10/ON switches on the level set previously (a method to switch on or off RF level and change between single and two-tone modulation as well is described with function AF1 and AF2).

Variation function

The variation increment for the VAR spinwheel is set using softkey 9 or 10/VAR/number/dimension or ENTER.

Reference function

The variation increment for the VAR spinwheel is set using softkey 9 or 10/REF/number/dimension or ENTER.

2.8.10 Oscilloscope / DC Measurement

Operation and use of the oscilloscope and the DC measurement feature are analogous to that as described in section 2.4.10.

2.9 RF Spectrum Analyzer

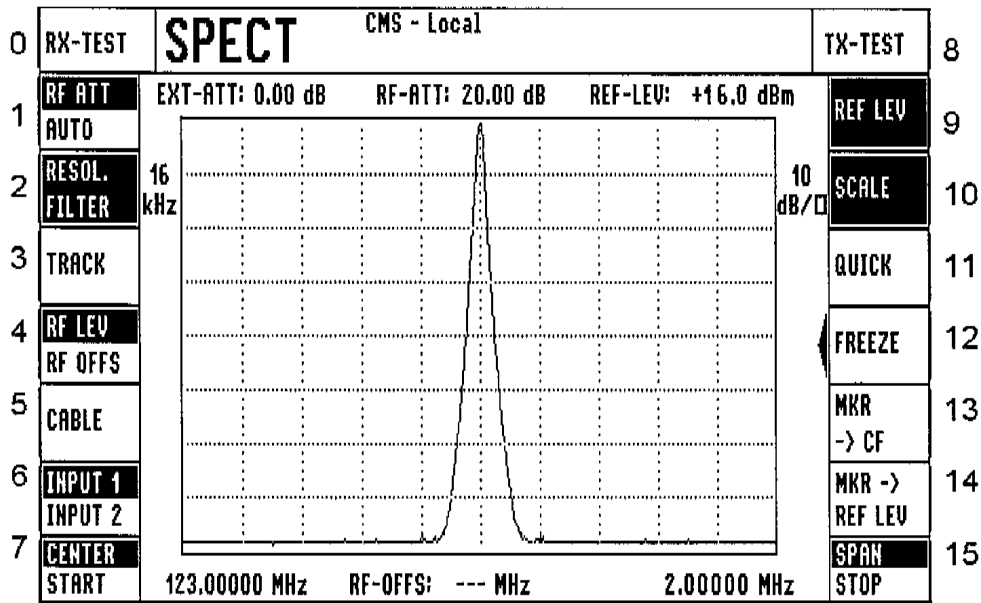

Fig. 2.9-1 Main menu of RF spectrum analyzer

The main menu of the RF spectrum analyzer can be selected from the selection menu by pressing the SPECT key.

In this menu, the CMS permits to display modulation spectra within one or a few channels as well as observe the complete frequency spectrum in the range from 10 MHz to 1 GHz.

The softkey 0 permits to branch directly into the main menu for the receiver test, softkey 8 into the main menu for the transmitter test.

In operating mode RF spectrum analyzer, all RF functions of the instrument are made use of, even if the duplex synthesizer is installed. Thus no duplex operation is possible.

2.9.1 Attenuation Setting

RF ATT/AUTO Function

For measurements via the connector RF IN/OUT, the spectrum analyzer is provided with switchable input attenuator pads in the range from 0 to 112.5 dB. This input attenuation can be selected manually, or it is set automatically depending on the power measured by the power meter and on the reference level set. The set value is indicated in the upper display area.

Changing from automatic setting to manual setting and vice versa is effected by pressing softkey 1.

For measuring small voltages via the sensitive input connector RF IN 2, RF level matching is not possible. The functions RF ATT and AUTO are at no significance in this case. The 2nd RF input attenuation (0 or 24 dB) is displayed next to softkey 6. *)

Manual attenuation setting:

In the position RF ATT, the user can set the attenuation himself in the range from 0 to 112.5 dB. Since the total attenuation is obtained by series-connection of single attenuator pads of fixed attenuation, not all values can be implemented. The CMS therefore rounds the entry to the next possible value. Note that a 20-dB power attenuator pad is automatically cut in when a high RF power (approx. >13 dBm) is applied.

*) depending on model or option

Automatic attenuation setting:

In the AUTO position, the power at the connector RF IN/OUT is measured internally in the CMS prior to each build-up of the display, which permits the optimum setting of the input attenuation to be determined automatically.

2.9.2 Resolution Filter Selection

RESOLUTION FILTER Function

This key is used to select the bandwidth of the resolution filter via which the frequency spectrum is weighted. The CMS provides 7 resolution filters with bandwidths from 150 Hz to 3 MHz. The set filter bandwidth is indicated opposite to the key.

Since, depending on the settings of the frequency span, not all filters allow for a useful display, their selection is restricted.

Table 2.9-1 Settable resolution filters depending on the frequency span set

| Span | Resolution filters | | | | | |
|-------------------|--------------------|---------|---------|---------|-------|----|
| | | | | | | |
| 2,4 kHz...30 kHz | 150 Hz | 6 kHz | 16 kHz | 50 kHz | | |
| 30 kHz...1,2 MHz | 6 kHz | 16 kHz | 50 kHz | 300 kHz | 1 MHz | |
| 1,2 MHz...3,2 MHz | 16 kHz | 50 kHz | 300 kHz | 1 MHz | 3 MHz | |
| 3,2 MHz...10 MHz | 50 kHz | 300 kHz | 1 MHz | 3 MHz | | |
| 10 MHz...50 MHz | 300 kHz | 1 MHz | 3 MHz | | | |
| 50 MHz...1 GHz | 1 MHz | 3 MHz | | | | *) |

2.9.3 Function Tracking Mode (only if fitted with CMS-B9/-B59) *)

TRACK Function

Softkey 3 permits to activate and deactivate the tracking mode (tracking generator). In this operating mode, an RF signal is output at the connector RF IN/OUT according to the span selected and the signal at the input connector RF IN 2 is displayed in the spectrum analyzer display. In this way, filter frequency responses can be recorded, for example.

Tracking mode is only possible if the CMS is provided with a duplex synthesizer. Besides, RF input 2 must be selected, because the test signal is generated at the connector RF IN/OUT.

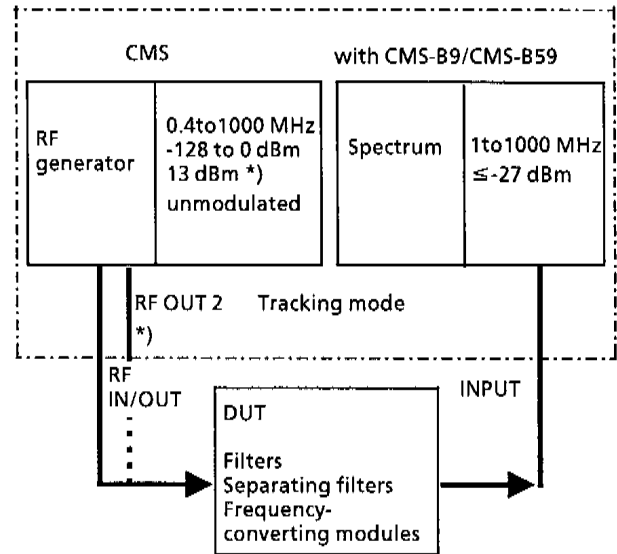

Fig. 2.9-2 Tracking mode

The frequency offset between the RF generator and the spectrum evaluation filter is user-definable from 0 to max. ± 999 MHz (dependent upon selected center frequency and display width).

Evaluation dynamic range: 50 dB (1 to 500 MHz)
45 dB (500 to 1000 MHz)

As in spectrum mode, various evaluation filters are available.

If the option CMS-B34 is fitted, higher output levels are output at the connector RF OUT 2. This is indicated in the display as follows: "!" . *)

2.9.4 RF Level and RF Offset

RF LEV/RF OFFS Function

Softkey 4 is used to set the level at the RF IN/OUT socket.

The RF OFFS function allows to define the difference in frequency between the RF IN/OUT socket and the RF IN2 socket, eg for measurements on frequency-converting modules. The measured value may either be positive or negative.

The settings for the RF level and offset frequency are shown in the upper part of the display as soon as the tracking key is active.

*) depending on model or option

2.9.5 Detection of Short-Circuits and Open-Circuits (Cable Fault Test) *)

CABLE Function *)

This function can be used to detect short circuits or open circuits in RF lines. To carry out the measurement, connect the CMS as shown in Fig. 2.9-3.

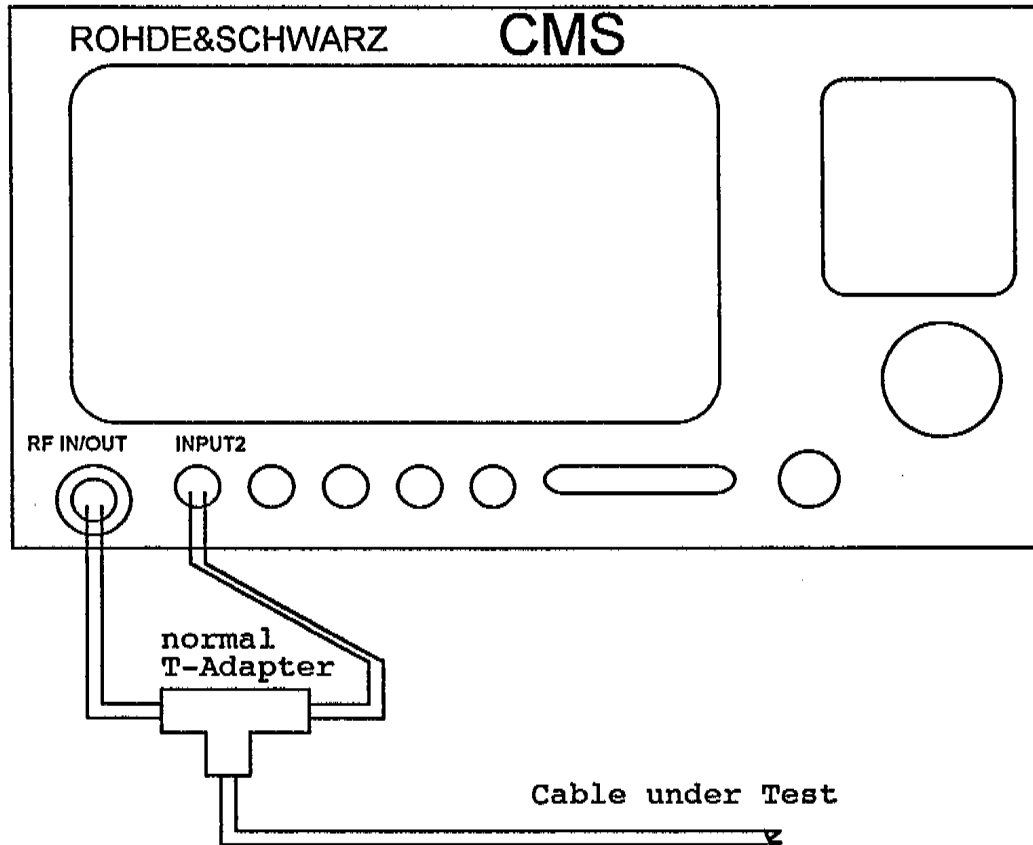

Fig. 2.9-3 Connection of the CMS for cable fault test

After the CABLE softkey has been pressed, the CMS activates the tracking mode and the following presettings are made:

| | |
|-----------------------|---------|
| starting frequency: | 0.4 MHz |
| stop frequency: | 200 MHz |
| RF input: | INPUT2 |
| reference level: | -27 dBm |
| RF transmitter level: | -37 dBm |

To obtain correct measurement results the parameter RF OFFS must be kept at 0.

In addition, the FREEZE key is activated so that recording is stopped after the first build-up of the display and the picture can be analyzed by the user.

Depending on whether there is a short circuit or an open circuit, different curves are obtained:

*) depending on model or option

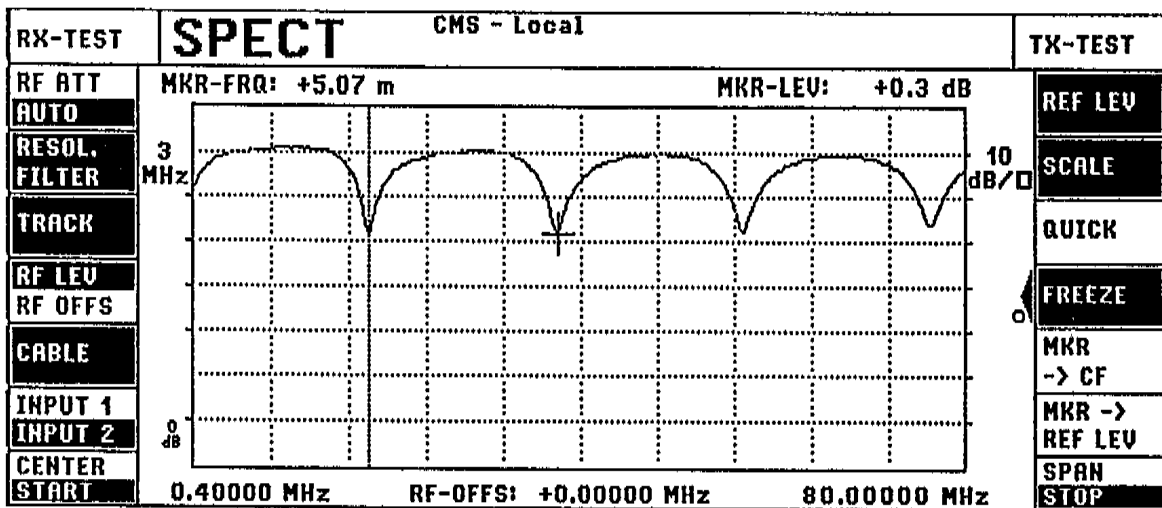

Fig. 2.9.4 Short-circuit at a distance of 5 m

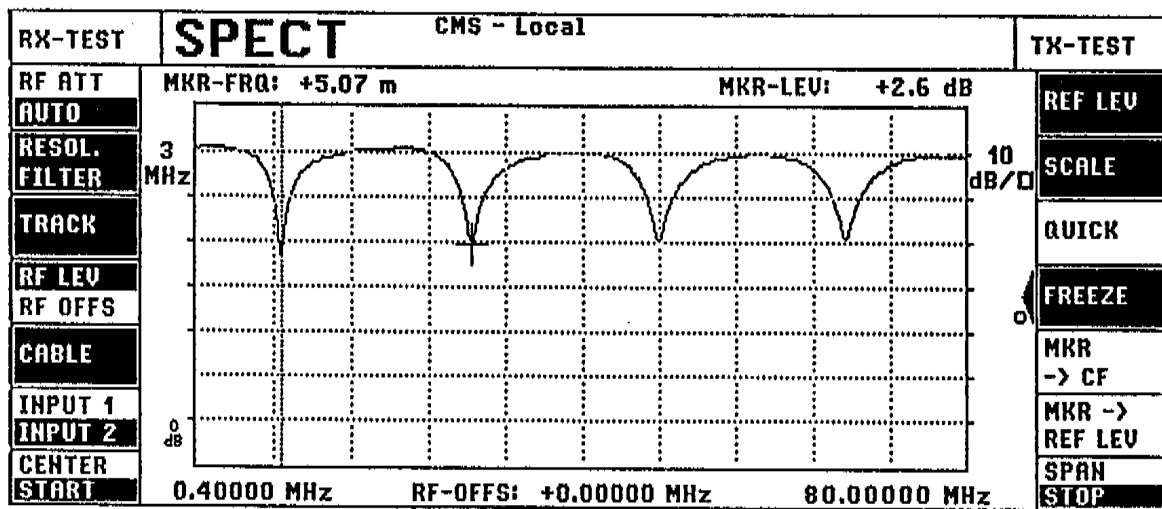

Fig. 2.9.5 Open-circuit at a distance of 5 m

In the case of a short-circuit, the recording shows a notch near the zero frequency (Fig. 2.9-4), while in the case of an open circuit the first notch only occurs in the half-distance frequency range (Fig. 2.9-5).

The distance to the open-circuit or the short-circuit is determined by placing the reference marker in a notch using the VAR rotary knob and hardkeys SHIFT/REF/ENTER. Now an adjacent notch is approached using the VAR rotary knob. The distance can be read in the upper area of the display in the unit meters.

If the active cursor is set on the softkey CABLE, the shortening factor can be entered on the keyboard. This factor is the ratio of the propagation speed of EM waves in a cable of a specific material to that in air. Reducing the propagation speed has the effect of shortening the wavelength.

Shortening factor values occurring in practise lie between 0.5 and 0.95. The value range of the CMS is 0.01 to 1.

The table below lists the shortening factor for common cable types:

| Cable type | Shortening factor |
|---------------------------------|-------------------|
| RG 58C | 0,66 |
| RG 400 | 0,66 |
| RG 142 | 0,69 |
| RG 402 | 0,69 |
| RG 214 | 0,66 |
| RG 393 | 0,69 |
| RG 401 | 0,69 |
| RG 196 | 0,7 |
| AGSC 3008 | 0,7 |
| Pair of coax. CCI cable, small | 0,95 |
| Pair of coax. CCI cable, normal | 0,95 |

2.9.6 Test Input Selection

INPUT 1 / INPUT 2 Function

This key permits to select the RF input via the connectors RF IN/OUT or RF IN 2. An external attenuation in the range from 0 to 100 dB can be entered for the two inputs. The numerical value is indicated in the upper display area with EXT ATT: -- dB.

2.9.7 RF Range Setting

CENTER / START / SPAN / STOP Function

These keys permit to define the RF frequency range, in which the RF input signal is analyzed.

The user may select between display with center and span frequency or with start and stop frequency. Switchover is possible by actuating one of the two keys CENTER / START or SPAN / STOP.

The selected settings are also valid for the RX test, submenu 2 of the SET RF function. Thus, an RF generator can be operated even if the option Duplex modulation tester is not fitted.

If entries are made for one of these functions, the CMS automatically selects a resolution filter depending on the set span so as to guarantee useful recording.

Table 2.9-2 Selection of the optimum resolution filter depending on the frequency span entered

| Span | Resolution filter |
|--------------------|-------------------|
| 1.2 kHz to 30 kHz | 150 Hz |
| 30 kHz to 1.2 MHz | 6 kHz |
| 800 kHz to 3.2 MHz | 16 kHz |
| 2.5 MHz to 10 MHz | 50 kHz |
| 8 MHz to 50 MHz | 300 kHz |
| 50 MHz to 1 GHz | 1 MHz |

In order to avoid unintentional, frequent variation of the resolution filters, Table 2.9-2 features hysteresis. A resolution filter setting is maintained as long as the frequency span is within the range of a row.

2.9.8 Reference Level Setting

REFLEV Function

The reference level indicates the level of the upper edge of the display. Thus, the level of the recorded signal can easily be determined at any point.

The limit values for the numerical entries of the reference level are dependent on the selection of the RF input. The RF attenuator pads or the pads connected at the RF IN/OUT or RF IN2 test inputs are taken into account for the limit values.

If signals are recorded via the connector RF IN/OUT, the reference level can be set at will in the range from -47 dBm to +47 dBm (+50 dBm with CMS-B32).

For RF input 2, the reference level can be set in the range from -67 dBm to -27 dBm.

Possible units for the reference level are W, V and dBUV.

2.9.9 Amplitude Resolution

SCALE Function

This function permits to vary the scale in the y-direction. Settings of 2, 5 and 10 dB/division are possible. The set value is indicated to the left of the key.

2.9.10 Sweep Rate

QUICK Function

This softkey can be used to affect the beam sweep rate. In default state (QUICK not active), 400 pixels (corresp. to 400 testpoints) are formed in a single sweep of the beam while with softkey QUICK active only 200 pixels are generated. The sweep time is thus reduced to roughly half of its previous value.

2.9.11 Freeze Function

FREEZE Function

Softkey 12 switches on and off the FREEZE function.

The Freeze function permits to stop the continuous build-up of the display. After pressing the key, the current build-up is finished and the curve then "frozen". A marker shaped as a cross appears at the maximum point of the curve. The frequency and level of the marker are indicated in the display. The marker can then be moved at will on the curve using the rotary knob VAR.

During Freeze mode, FM-modulated signals can be demodulated at the frequency defined by the marker.

The settings for AM, FM, ϕ M demodulation, IF filter (WIDE/NARROW), the demodulator status (ON/OFF/SQUELCH), and the setting of the loudspeaker (AMP softkey) are taken from the TX test.

A reference marker can be set at the position of the marker positioned before using keys SHIFT/REF/ENTER. The active cursor must be on the FREEZE key.

The reference marker is displayed in the form of a vertical line. If the reference marker is activated, the marker frequency and the marker level are displayed as a deviation from the reference position.

The reference marker function can be deactivated by keys SHIFT/REF/CLEAR. It is also cancelled with every new build-up of the display. The marker frequency displayed can be defined as centre frequency by way of softkey 13 (MKR \rightarrow CF). Softkey 14 (MKR \rightarrow REFLEV) serves to turn the indicated marker level into the reference level.

Thus the user is allowed to position a part of the recorded curve that is important to him into the middle of the picture with only a few keystrokes.

Both keys can only be operated if FREEZE has been activated. Pressing of these keys initiates a new build-up of the display.

These actions lead again to a sweep in order to show the modified display.

If the TX test is activated in the Freeze function after the marker appears, the current marker frequency is accepted as the value for the SET RF function of menu TX test (softkey 1).

2.10 Definition Menu for Tones

| | | | | | | | | |
|---|---------|--------------|-------------------------|-----------|-------------|-------------|---------|----|
| 0 | RX-TEST | TONES | CMS - Local HARDCOPY | | | | TX-TEST | 8 |
| 1 | STD | Std.01 ZVEI1 | 0: Fix. Freq. | 6: VDEW | 12: unused | COUPLED | DECODE | 9 |
| | RESET | | 1: ZVEI1 | 7: EURO | 13: reserv. | INDEPENDENT | -> CODE | |
| 2 | NO SPEC | 1 | 2: ZVEI2 | 8: CCITT | 14: unused | 10000 ms | DECODE | 10 |
| | LENGTH | 70 ms | 3: CCIR | 9: NATEL | 15: CCSS | | TIME | |
| 3 | OTHER | 70 ms | 4: EEA | 10: DTMF | 16: ATIS | | 1stTONE | 11 |
| | PAUSE | 0 ms | 5: EIA | 11: VDEWd | 17: unused | | 2ndTONE | |
| 4 | TONE 0 | 2400.0 Hz | 0.0 Hz | 2000.0 Hz | 0.0 Hz | | TONE 8 | 12 |
| | TONE 1 | 1060.0 Hz | 0.0 Hz | 2200.0 Hz | 0.0 Hz | | TONE 9 | |
| 5 | TONE 2 | 1160.0 Hz | 0.0 Hz | 2799.9 Hz | 0.0 Hz | | TONE A | 13 |
| | TONE 3 | 1270.0 Hz | 0.0 Hz | 810.0 Hz | 0.0 Hz | | TONE B | |
| 6 | TONE 4 | 1400.0 Hz | 0.0 Hz | 970.0 Hz | 0.0 Hz | | TONE C | 14 |
| | TONE 5 | 1530.0 Hz | 0.0 Hz | 886.0 Hz | 0.0 Hz | | TONE D | |
| 7 | TONE 6 | 1670.0 Hz | 0.0 Hz | 2599.9 Hz | 0.0 Hz | | TONE E | 15 |
| | TONE 7 | 1830.0 Hz | 0.0 Hz | 0.0 Hz | 0.0 Hz | | TONE F | |

Fig. 2.10-1 Main menu TONES

Starting with the main menus of the selection menu the main menu TONES (definition menu for tones) is reached by pressing the softkey TONES.

It contains all controls required to define parameters such as frequency, tone duration, pause duration and further parameters for output of the tone sequence and evaluation. The parameters are used in the transmitter and receiver test menus.

Softkey 0 allows for direct branching to the main menu for the receiver test and softkey 8 for branching to the transmitter test.

2.10.1 Selection of Standard

STD/RESET Function

The standards are named and called by numbers. These can be used according to the original standard or be modified as required.

| Number (= Std.No.) | Unmodified | Modified |
|-----------------------|-------------------------|----------|
| 0 | Std.0 Fixed Frequencies | Std.0 |
| 1 | Std.1 ZVEI 1 | Std.1 |
| 2 | Std.2 ZVEI 2 | Std.2 |
| 3 | Std.3 CCIR | Std.3 |
| 4 | Std.4 EEA | Std.4 |
| 5 | Std.5 EIA | Std.5 |
| 6 | Std.6 VDEW | Std.6 |
| 7 | Std.7 EURO | Std.7 |
| 8 | Std.8 CCITT | Std.8 |
| 9 | Std.9 NATEL | Std.9 |
| 10 | Std.10 DTMF *) | Std.10 |

*) depending on model or option

Standards 1 to 9 represent the usual single-tone sequences. For differentiation of unmodified and modified tone sequences the CMS displays standard number and name for unmodified tone sequences, but only the standard number for modified tone sequences.

The assignment of frequencies to numbers is displayed in the main menu for tones and can be modified. Standard 0 reacts like a completely normal tone sequence standard. In this case the frequencies are the fixed frequencies for the AF generators. Standard 10 is the dual-tone standard; it cannot be modified for evaluation purposes.

Softkey 1 allows for calling any standard in order to modify it (STD) or to reset the original parameters for the selected standard (RESET). The SHIFT key is used to select between these two possibilities.

The standard is called by entering `softkey 1 (STD) /number /ENTER`. A standard is reset to the original state by entering `softkey 1 (RESET) /number /ENTER`.

Note: *Std. 11 (VDEW d) consists of the data records of Std. 1 (ZVEI 1) and STD. 10 (DTMF) and therefore cannot be selected in this menu, but only from the CODE submenu 1 or DECODE submenu 2.*

Hinweis zu ATIS / CDCSS:

The generation and decoding of following tone sequences is implemented in addition to the standard ones:

- CDCSS coding
- CDCSS decoding: *)
requires option CMS-B27 and CMS-B33
- ATIS coding: *)
requires option CMS-B27
- ATIS decoding: *)
requires option CMS-B27

Function description

- **ATIS**
ATIS is an automatic transmitter identification system, i.e. after the transmission key of the mobile phone has been released, an identification message is sent. This identification message must be repeated at least once every 5 minutes with longer transmissions.
Data message: 360 Bit
Data modulation: FSK with a baud rate of 1200 Bit/s
0 corresponds to 2100 Hz; 1 corresponds to 1300 Hz
RF modulation: phase modulation with a modulation index of 2.0 rad
- **CDCSS**
CDCSS is a digital code parallel to speech whose identification is used by an addressed mobile phone to make itself ready to receive information. The end of the transmit mode is announced by sending a turn-off code so that the receiver can turn off without disturbing noise effects.

Data message: 23 bits with continuous repetition
Bit length: 7.44 ms
Modulation: Direct carrier shift keying with a settable deviation, depending on the class of mobile phone.

The following 83 octal codes are permissible

| | | | | | | | |
|-----|-----|-----|-----|-----|-----|-----|-----|
| 023 | 072 | 152 | 244 | 343 | 432 | 606 | 723 |
| 025 | 073 | 155 | 245 | 346 | 445 | 612 | 731 |
| 026 | 074 | 156 | 251 | 351 | 464 | 624 | 732 |
| 031 | 114 | 162 | 261 | 364 | 465 | 627 | 734 |
| 032 | 115 | 165 | 263 | 365 | 466 | 631 | 743 |
| 043 | 116 | 172 | 265 | 371 | 503 | 632 | 754 |
| 047 | 125 | 174 | 271 | 411 | 506 | 654 | |
| 051 | 131 | 205 | 306 | 412 | 516 | 662 | |
| 054 | 132 | 223 | 311 | 413 | 532 | 664 | |
| 065 | 134 | 226 | 315 | 423 | 546 | 703 | |
| 071 | 143 | 243 | 331 | 431 | 565 | 712 | |

2.10.2 Tone Duration



Softkey 2 is assigned two functions. The SHIFT key is used to select the first or second function.

Softkey 2: NO SPEC

This function is used to define, which tone of the selective-call sequence is to be subjected to special tone duration.

Normally this is the first tone of extended tone duration compared to the other tones. The entry is made using `softkey 2 (No SPC) /number (tone duration in ms) /ENTER`.

Softkey 2: LENGTH

Each individual standard is assigned a tone duration, which can, however, also be influenced using `softkey 2 (LENGTH) /number (tone duration in ms) /ENTER`.

*) depending on model or option

2.10.3 Pause

OTHER/PAUSE Function

Softkey 3 is assigned two functions. The SHIFT key is used for selecting the first or second function.

Softkey 3: OTHER

This softkey is used for determining the tone duration of the other tones by entering `softkey 3 (OTHER)/number (tone duration in ms)/ENTER`.

Softkey 3: PAUSE

The pause duration between the tones defined by entering `softkey 3 (PAUSE)/number (tone duration in ms)/ENTER`.

2.10.4 Frequency Definition

TONE Function

The complete lower half of the screen is available for definition of frequencies. 8 softkeys with dual function (4 to 7, 12 to 15) are provided for the entry of 16 different frequencies or frequency pairs. The tone numbers correspond to the numbers (incl. A to F) of the "dialling number". The digits * and # are used for standard 10 (DTMF) instead of E and F. Again, `SHIFT/softkey..` is used for switching between first and second function of a softkey.

A frequency or frequency pair can be entered for each digit, i.e. standards can consist of single or dual tones or even be mixed of single and dual tones. Single tones are produced by selecting 0 in the right softkey column. The selection of right or left column is made by pressing softkey 11. Again, `SHIFT/softkey 11` is used to select the first function (left softkey column) or the second function (right softkey column) or vice versa.

The frequencies are entered by `softkey../number/ENTER`. The frequencies are displayed in Hz.

The range for standard 0 is 100 Hz to 20 kHz and for standards 1 to 10 it is 300 Hz to 4 kHz.

The frequencies thus defined are valid for standards 0 to 10 (modified or unmodified) for output of tone sequences. For evaluation the frequencies of the first softkey column apply (modified or unmodified), however, only for standards 0 to 9. The lower tone number (digit) is decoded in case of frequency repeats. With standard 10 selected, the double tones of the unmodified standard are decoded.

2.10.5 Coupling of Standards

DECODE → CODE Function

Softkey 9 is used to determine, whether coder and decoder work with the same standard or not. In the first case a change of standard for the coder automatically leads to a change of standard with the decoder and vice versa (normal operation). In the other case coder and decoder can be set individually.

2.10.6 Decoding Time

DECODE TIME Function

This function is especially of interest in automatic operation (IEC/IEEE bus and autorun control). The decoding time set here causes abortion of decoding after this time elapsed, independent of tones following or not.

The decoding time is entered using `softkey 10/number (decoding time in ms)/ ENTER`.

Application:

With acknowledgement call operation the CMS sends out a call, then evaluates the reply. Or the transceiver first sends a call; starting with this call the CMS first waits until the decoding time set via softkey 10 has passed, then continues the program by a reply selective call or any other action. This function is required for the signalling operation within the Swiss mobile telephone system NATEL B.

2.11 Special Signalling *) (with option CMS-B27 and B33 only)

2.11.1 ATIS

ATIS is an automatic transmitter identification system, i.e. after the transmission key of the mobile phone has been released, an identification message is sent. This identification message must be repeated at least once every 5 minutes with longer transmissions.

- Data message: 360 bit
- Data modulation: FSK with a baud rate of 1200 Bit/s
0 corresponds to 2100 Hz; 1 corresponds to 1300 Hz
- RF modulation: phase modulation with a modulation index of 2.0 rad

DECODE ATIS (standard 16) function:

The ATIS code is decoded by pressing the DECODE/ENTER key. A single signalling telegram in line with ATIS regulation (BAPT 225 ZV 4-1/53A) is expected. The ATIS self-identification decoded from the received telegram is shown as a 10-digit decimal number.

This value is split up into several blocks that are separated by blank spaces. It is made up of the following components: waterway code (1 digit), nationality code (3 digits), the second letter of the selective-call number (2 digits) and the remaining numbers (4 digits). An example of the identification code:

9 211 (or 218) 01 1234
 | |
 Rhine Germany

The following error messages can additionally be displayed in the status line:

- ATIS-MESSAGE FAIL (bit error in the telegram).
- PARITY CHECK ERROR (error check character not completely correct).
- ATIS-TIMEOUT.

If no signal is received within the ATIS timeout of 6 min., the symbol --- appears on display.

- Decode ATIS: Submenu 1
Submenu 1 is of no significance for ATIS.
- Decode ATIS: Submenu 2
Softkeys EVAL BNDWTH and MAX PAUSE are not relevant.

2.11.2 CDCSS

CDCSS is a digital code parallel to speech whose identification is used by an addressed mobile phone to make itself ready to receive information. The end of the transmit mode is announced by sending a turn-off code so that the receiver can turn off without disturbing noise effects.

- Data message: 23 bits with continuous repetition
- Bit length: 7.44 ms
- Modulation: Direct carrier shift keying with a settable deviation, depending on the class of mobile phone.

The following 83 octal codes are permissible:

| | | | | | | | |
|-----|-----|-----|-----|-----|-----|-----|-----|
| 023 | 072 | 152 | 244 | 343 | 432 | 606 | 723 |
| 025 | 073 | 155 | 245 | 346 | 445 | 612 | 731 |
| 026 | 074 | 156 | 251 | 351 | 464 | 624 | 732 |
| 031 | 114 | 162 | 261 | 364 | 465 | 627 | 734 |
| 032 | 115 | 165 | 263 | 365 | 466 | 631 | 743 |
| 043 | 116 | 172 | 265 | 371 | 503 | 632 | 754 |
| 047 | 125 | 174 | 271 | 411 | 506 | 654 | |
| 051 | 131 | 205 | 306 | 412 | 516 | 662 | |
| 054 | 132 | 223 | 311 | 413 | 532 | 664 | |
| 065 | 134 | 226 | 315 | 423 | 546 | 703 | |
| 071 | 143 | 243 | 331 | 431 | 565 | 712 | |

DECODE CDCSS (standard 15) function:

The CDCSS code is decoded by pressing the DECODE/ENTER key. A cyclically repeated CDCSS signalling telegram in the subaudio band is expected. If one of the 83 permissible message is received, it will be displayed as a 3-digit octal number. In addition, any inverted message is displayed with the prefix # (example: 023 = #047).

If none of the defined 83 CDCSS codes is received, the decoded bit sequence will be displayed as a 3-digit hexa-decimal number prefixed with !.

*) depending on model or option

If no signal is received within the timeout, the symbol – – – appears on display.

Note:

The CDCSS signal can be evaluated via the AF/SCOPE input for AF measurement or via INPUT 1 or INPUT 2 as a FM-demodulated signal.

- Decode CDCSS: Submenu 1
Submenu 1 is of no significance for CDCSS.
- Decode CDCSS: Submenu 2
Softkeys EVAL BNDWTH and MAX PAUSE are not relevant.

2.12 Definition menu for Special Functions

| | | | | | | |
|---|---------------------------|------------------------------------|--------------------------------|--------------------------------|----------------|----|
| 0 | CONFIG CMS - Local | | | ↓ | SERIAL | 8 |
| 1 | SEARCH ROUTINE | 120000 ms | TIMEOUT | R&S-PDN HP-PCL EPSON NEC-P7 | PRINTER TYPE | 9 |
| 2 | | | | 600 Ω | AF-TRANSF | 10 |
| 3 | ILLUM | ON OFF/HALF 5min 1h | REFERENCE R : | 600 Ω | AF VOLT | 11 |
| 4 | CTRL | CMS-B1/B2 OCXO CMS-B32 100 W RF | CMS-B34 13dBm Output | CMS-B22 | REF FRQ EXTERN | 12 |
| 5 | ZOOM | CMS-B5 CCITT CMS-B27 ATIS/CDCSS | CMS-B33 300 Hz LP | | KEY BEEP | 13 |
| 6 | LO HIGH | CMS-B9 Duplex, ACP | | | WARNING | 14 |
| 7 | IEEE ADDRESS | 24 | SW-Version: X 4.925, 30.5.1995 | | MASTER RESET | 15 |

Fig. 2.12-1 Main menu CONFIG (special functions)

Starting with the main menus of the selection menu the main menu CONFIG (definition menu for special function) is entered by pressing the softkey CONFIG.

2.12.1 Search Routines

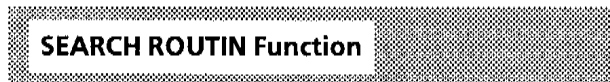

The timeout value can be determined for the search routines using this function.

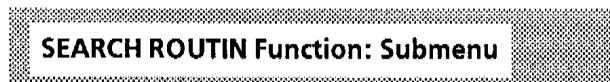

A submenu is available for the SEARCH ROUTIN function, which is output in the display fields next to the softkeys 2 to 7.

| | | |
|------------------|-----------|-----------|
| SEARCH ROUTINE | 120000 ms | TIMEOUT |
| 2 RF LEVEL | 10.00 mV | UP LIMIT |
| 3 AF LEVEL | 1.00 V | UP LIMIT |
| 4 SQUELCH THRESH | 50.0 mV | |
| 5 SQUELCH DELAY | 20 ms | |
| 6 ATTACK TIME | 200 ms | PEAK HOLD |
| 7 REFS TIME | 500 ms | PEAK HOLD |

Fig. 2.12-2 SEARCH ROUTIN submenu

Softkey 2: RF LEVEL

Softkey 2 can be used to define the upper RF level limit with search routines.

Softkey 3: AF LEVEL

Softkey 3 can be used to define the upper AF level limit with search routines.

Softkey 4: SQUELCH THRESH

Softkey 4 can be used to define the threshold value for squelch on or squelch off with AF level measurements.

Softkey 5: SQUELCH DELAY

Using softkey 5, the delay time for slowing down the test cycle with the squelch measurement can be defined.

Softkey 6/7: ATTACK TIME/MEAS TIME

In IEC-bus or autorun mode the PK HOLD measurement is a single, time-limited process.

MEAS TIME means the time during which the peak value meter evaluates all the voltage peaks occurring. ATTACK TIME is the time by which evaluation is delayed after command execution.

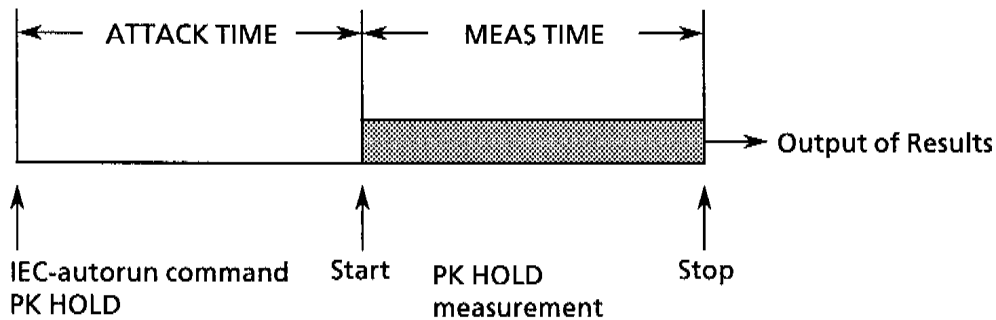

2.12.2 Display Illumination

ILLUM Function

Illumination of the display can be switched on and off using softkey 3 (ILLUM).

ON: Illumination of the CMS remains activated.

OFF/HALF: Illumination of the CMS is deactivated or switched to half brightness.

5 min:

1 h: After 5 min/1 h the CMS switches illumination off or to half brightness, if no key was activated during this time.

2.12.3 Relay and TTL Interface *)

(Cf. also Fig. 2.12-4: pin assignment of the CONTROL connector)

CTRL Function

Pressing the CTRL softkey calls the submenu CTRL.

CTRL Function: Submenu

The CTRL function has a submenu, which is output in the display fields next to softkeys 2 to 7.

*) depending on model or option

| | | |
|----------------|--------------------------------|---------|
| SEARCH ROUTINE | 120000 ms | TIMEOUT |
| 2 RELAY SET | 00: 0000 0000 | |
| 3 HES / DEC | HES DEC | |
| 4 RX/TX CTRL | | |
| 5 TTL IN/OUT | 000: 0000 0000 0000 | |
| 6 HES / DEC | HES DEC | |
| 7 IN/OUT CTRL | IN_IN IN_OUT OUT_IN OUT_OUT | |

Fig. 2.12-3 CTRL submenu

Softkey 2: RELAY SET

All relays can be set and reset individually or jointly. The two least significant hexadecimal positions determine which relay is influenced.

1. Setting all relays: range of values between 0 and 255 (0 and FF Hex)

All relays are set irrespective of the previous setting in accordance with the binary number.

e.g. setting all relays:

previous setting: 55 Hex = 0101 0101 B
 entered value: 0F Hex = 0000 1111 B
 new setting: 0F Hex = 0000 1111 B

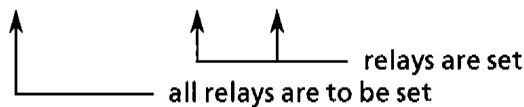

2. Setting individual relays: range of values between 0 and 255 + 256 (100 and 1FF Hex)

All indicated relays with the binary number "1" are set, relays with binary value "0" are not influenced.

e.g.: setting all less significant relays, leaving the more significant relays unaffected.

previous setting: 55 Hex = 0101 0101 B
 entered value: 10F Hex = 0000 1111 B
 new setting: 5F Hex = 0101 1111 B

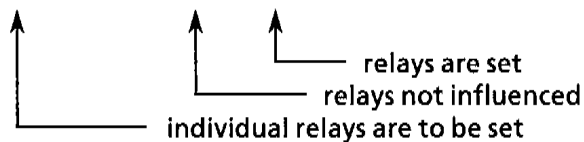

3. Resetting individual relays: range of values between 0 and 255 + 512 (200 and 2FF Hex)

All indicated relays with the binary number "1" are reset, relays with binary value "0" are not influenced.

e. g.: resetting all less significant relays, leaving the more significant relays unaffected.

previous setting: 55 Hex = 0101 0101 B

entered value: 2 0F Hex = 0000 1111 B

new setting: 5F Hex = 0101 0000 B

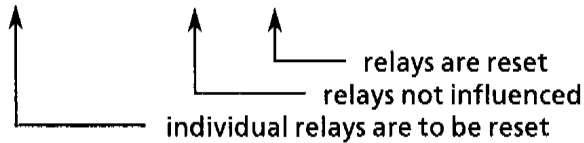

Note: Some options do not have 8 relays. In this case relays not available are marked by X.

Softkey 3: HEX / DEC

Softkey 3 can be used to select whether the relay position is to be entered in decimal or hexadecimal form.

Softkey 4: RX / TX CTRL

When softkey 4 is pressed, the most significant relay is switched off with menu changeover to the RX test, and switched on with menu changeover to the TX test. An RX-TX switchover with the RF power does not change the relay.

Softkey 5: TTL IN / OUT

Softkey 5 can be used to have the TTL interface read and/or written to. All TTL lines can be set and reset individually or jointly. The three least significant hexadecimal positions and the respective programming of the TTL interface by softkey 7 determine which TTL lines are influenced.

Example for TTL IN/OUT (IN/OUT CTRL = OUT_OUT)

- Setting all TTL lines: range of values between 0 and 4095 (0 and FFF Hex)

All TTL lines are set irrespective of the previous setting in accordance with the binary value.

e. g.: setting all TTL lines.

previous setting: 255 Hex = 0010 0101 0101 B

entered value: 0 00F Hex = 0000 0000 1111 B

new setting: 25F Hex = 0000 0000 1111 B

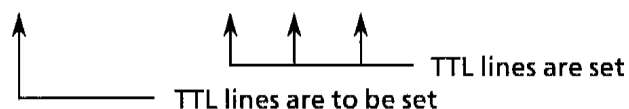

- Setting individual TTL lines: range of values between 0 and 4095 + 4096 (1000 and 1FFF Hex)

All indicated TTL lines with the binary number "1" are set, TTL lines with binary value "0" are not influenced.

e. g.: setting all less significant 4 TTL lines, leaving all more significant lines unaffected.

previous setting: 255 Hex = 0010 0101 0101 B

entered value: 1 00F Hex = 0000 0000 1111 B

new setting: 25F Hex = 0010 0101 1111 B

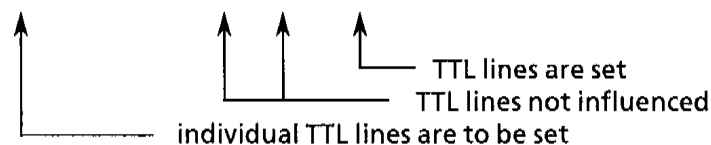

3. Resetting individual TTL lines: range of values between 0 and 4095 + 8192 (2000 and 2FFF Hex)

All indicated TTL lines with the binary number "1" are reset, TTL lines with binary value "0" are not influenced.

e. g.: resetting all less significant 4 TTL lines, leaving all more significant lines unaffected.

previous setting: 255 Hex = 0010 0101 0101 B
 entered value: 2 00F Hex = 0000 0000 1111 B
 new setting: 25F Hex = 0010 0101 0000 B

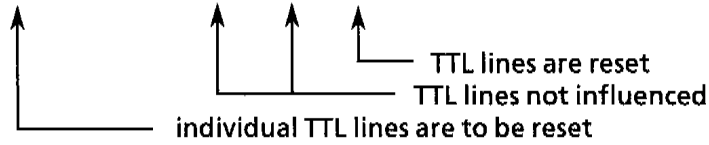

Softkey 6: HEX / DEC

Softkey 6 can be used to select whether the TTL lines are to be entered in decimal or hexadecimal form.

Softkey 7: IN / OUT CTRL

This functions sets the TTL interface to input or output.

- IN_IN: All TTL lines are set to input. 12 external TTL lines are read.
- IN_OUT: The upper four TTL lines are set to input and are read, the internal eight TTL lines are written to.
- OUT_IN: The upper four TTL lines are set to output and are written to, the lower eight TTL levels are read.
- OUT_OUT: All TTL lines are set to output and are written to.

The upper four TTL lines in the setting IN-IN or IN-OUT can be used to control AUTOTEST programs. The line at D12 has the symbolic name "BCD-3", D9 "BCD-0".

Note: CMS frames for options do not all have 12 TTL lines. If there are less than 12 lines, the non-existing lines are marked with an X. In this case, lines D1 to D4 in the settings IN-IN and OUT-IN can be used to control AUTOTEST events BCD-0 (D1) to BCD-3 (D4).

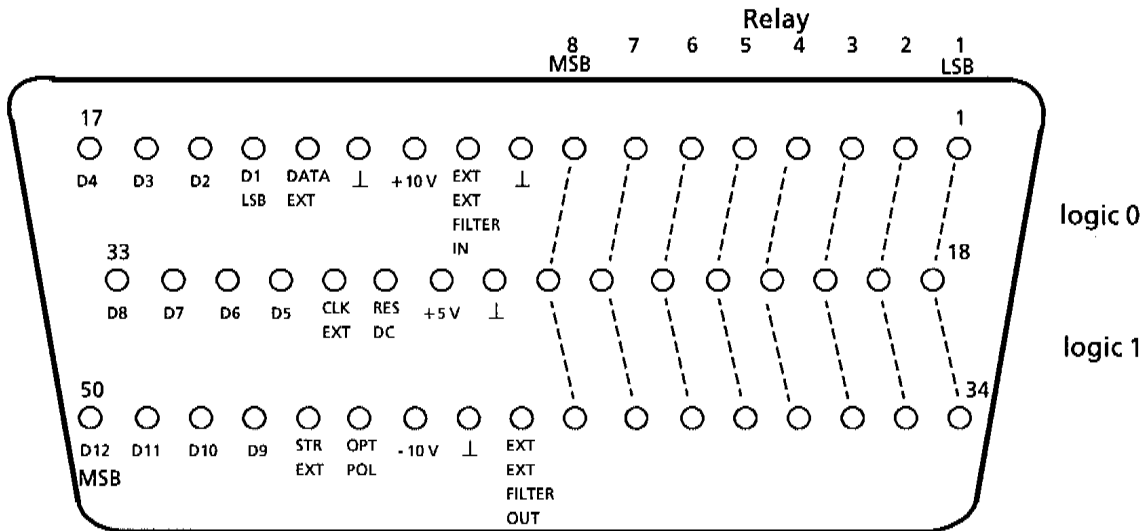

Fig. 2.12-4 Pin assignment of connector CONTROL

2.12.4 ZOOM

ZOOM Function

The ZOOM function is switched on (light characters on a dark background) and off (dark characters) using softkey 5 (ZOOM). With the ZOOM function switched on, analog indications in the TX-test menu and RX-test menu are shown in magnified display; the oscilloscope is switched off in this operating mode.

2.12.5 LO Frequency LO/HIGH

LO HIGH Function

This softkey is used to set the LO frequency for conversion into the internal IF frequency of 455 kHz above or below the carrier frequency (standard setting is LO HIGH invers: LO frequency below carrier frequency).

2.12.6 IEC/IEEE Bus *)

IEEE ADDRESS Function

This function serves for setting the IEC/IEEE-bus address. The value range of the address is 0 to 30. The address is entered using `softkey 2/number/ENTER`. The default address setting is 24.

2.12.7 SERIAL *)

This softkey allows branching to the RS232 main menu provided the option is built in.

2.12.8 Selection of Printer

PRINTER TYPE Function

Various printer types may be selected on actuation of softkey 9 (toggle function).

2.12.9 600-Ω AF Transformers*)

AF-TRANSF Function

A 600-Ω transformer can be connected each into the AF voltmeter input (AF/SCOPE) and modulation generator output (MOD GEN), using softkey 10 (AF-TRANSF) (with setting "600 Ω" selected). The level indications of AF voltmeter and modulation generator are appropriately corrected in this mode.

2.12.10 AF Voltmeter (Reference Resistance)

AF VOLTM Function

The AF level measurement normally refers to a load resistance of 600 Ω.

Another load resistance can be selected using this function. The entry is made using `softkey 11/number/ENTER`, the number representing the reference resistance in Ω.

2.12.11 External Reference Frequency*)

REF FRQ EXTERN Function

Actuating softkey 12 switches off the internal 10-MHz reference frequency. This means that all frequencies of the CMS are inaccurate if option CMS-B22 is not fitted or no 10-MHz input signal is available.

*) depending on model or option

2.12.12 Acoustic Acknowledgement

KEY BEEP Function

The softkey KEY BEEP is used for selecting whether each keystroke is to be acoustically acknowledged or not.

2.12.13 Warnings

WARNING Function

The WARNING softkey is used to select whether warning messages are displayed by the CMS or not. These warning messages are hints to possible erroneous operation. Hints on real conflicts are always indicated in the status line.

2.12.14 Master Reset

MASTER RESET Function

The instrument is set to the factory setting using the softkey MASTER RESET. A request to acknowledge safeguards the operator from inadvertent action.

2.13 Remote Control*)

The IEC/IEEE bus interface corresponds to the IEC 625-1 or IEEE 488.1 standard and to IEEE 488.2 also approved of by the IEC commission. This standard describes data transfer formats and common commands etc.

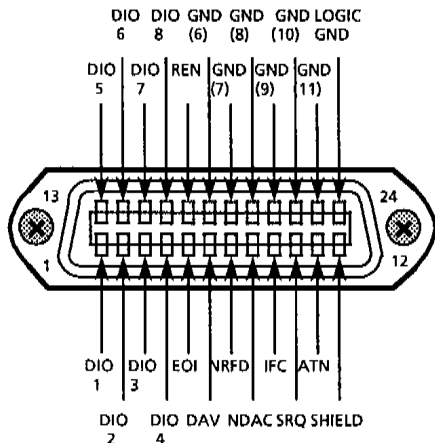

Fig. 2.13-1 Pin assignment of socket 48

The bus connection socket 48 is fitted to the rear of the instrument. The instrument is equipped with the 24-contact socket according to the IEEE 488 standard. The interface contains three groups of bus lines:

1. Data bus with 8 lines DIO 1 to DIO 8

Data transmission is bit-parallel and byte-serial with the characters in ISO 7-bit code (ASCII code).

DIO 1 represents the least significant bit and DIO 8 the most significant bit.

2. Control bus with 5 lines

This is used to transmit control functions:

ATN (Attention)

becomes active Low when addresses, universal commands or addressed commands are transmitted to the connected devices.

REN (Remote Enable)

enables the device to be switched to the remote status.

SRQ (Service Request)

enables a connected device to send a Service Request to the controller by activating this line.

IFC (Interface Clear)

is activated by the controller in order to set the IEC interfaces of the connected devices to a defined status.

EOI (End or Identify)

is used to identify the end of data transfer and is used with a parallel poll.

3. Handshake bus with 3 lines

Used to control the data transfer timing.

NRFD (Not Ready For Data)

an active Low on this line signals to the talker/controller that one of the connected devices is not ready to accept data.

DAV (Data Valid)

is activated by the talker/controller shortly after a new data byte has been applied to the data bus.

NDAC (Not Data Accepted)

is held at active Low by the connected device until it has accepted the data present on the data bus

Detailed information on the data transfer timing is available in the IEC 625-1 standard.

According to the IEC 625-1 standard, devices controlled via the IEC bus can be equipped with different interface functions. Table 2-13-1 lists the interface functions applicable to the instrument:

*) depending on model or option

Table 2.13-1 Interface functions

| Control characters | Interface function |
|--------------------|--|
| SH1 | Source Handshake function, complete capability |
| AH1 | Acceptor Handshake function, complete capability |
| L4 | Listener function, complete capability, unaddress if MTA |
| T6 | Talker function, complete capability, capability to reply to serial poll, unaddress if MLA |
| SR1 | Service Request function, complete capability |
| PP1 | Parallel Poll function, complete capability |
| RL1 | Remote/Local switchover function, complete capability |
| DC1 | Device Clear function, complete capability |
| DT0 | Device Trigger function, no Device Trigger |
| C0 | Controller function, no controller function |

2.13.1 Setting the Device Address

The device address can be set in the CONFIG menu using the IEEE ADDRESS function. The address between 0 and 30 is entered using the numeric keys and remains stored when the device is switched off. The instrument is factory-set to address 24.

The address is the decimal equivalent of bits 1 to 5 of the Talker or Listener address. This form is also used with the IEC-bus command of the controller.

2.13.2 Local/Remote Switchover

The device is in the Local state (manual mode) when switched on.

If the instrument is addressed as a Listener by a controller, it enters the Remote state in line with the standard and remains in this state after data transfer has been completed. All controls on the front panel except the STOP(LOCAL) key are disabled.

There are two methods to return to the "Local" state:

- by the addressed command GTL (Go to Local) from the controller.
- by pressing the STOP key. Data output from the controller to the instrument should be stopped before pressing the STOP key for otherwise the instrument will immediately enter the Remote state again. The function of the STOP key can be disabled by the controller by sending the universal command LLO (Local Lockout).

The other device settings are not changed when switching from Remote to Local state or vice versa.

When the CMS is switched to the Local state, the respective main menu of the current operating mode is indicated.

2.13.3 Interface Messages

Interface messages (according to IEC 625-1/IEEE 488 standard) are transmitted to the device on the data lines where the Attention line ATN is active (low).

2.13.3.1 Universal Commands

The universal commands have codes between 10 and 1F hexadecimal (see Table 2.13-4). They act, without previous addressing, on all devices connected to the bus.

Table 2.13-2 Universal commands

| Command | Basic command with R&S controllers | Function |
|---------------------------|------------------------------------|---|
| DCL (Device Clear) | IECDCL | Aborts processing of the currently received commands and sets the command processing software to a defined initial status. The device setting is not changed. |
| LLO (Local Lockout) | IECLLO | The STOP key is disabled. |
| SPE (Serial Poll Enable) | IECSPE * | Ready for serial poll. |
| SPD (Serial Poll Disable) | IECSPD * | End of serial poll. |

* The BASIC command "IECSPL adr, status" contains the commands "IECSPE" and "IECSPD" and additionally reads the status of the device with address "adr" and stores this in the integer variable "status".

2.13.3.2 Addressed Commands

The addressed commands have codes between 00 and 0F hexadecimal (see Table 2.13-4). They only act on devices addressed as Listeners (by the BASIC command "IECLAD addr").

Table 2.13-3 Addressed commands

| Command | Basic command with R&S controllers | Function |
|-----------------------------|------------------------------------|---|
| SDC (Selected Device Clear) | IECSDC | Aborts processing of the currently received commands and sets the command processing software to a defined initial status. The device setting is not changed. |
| GTL (Go To Local) | IECGTL | Change to Local state (manual operation) |

Table 2.13-4 ASCII/ISO and IEC-character set

| Control characters | | | | Numbers and special characters | | | | Upper-case letters | | | | Lower-case letters | | | | | |
|---------------------------|-----|-----|---------------------------|--------------------------------|-----|---------------------------|----|--------------------|-------------------------|----|---|---|---|-----|---|-----|-----|
| 0 | NUL | | 16 | DLE | | 32 | SP | 48 | 0 | 64 | @ | 80 | P | 96 | ` | 112 | p |
| 1 | SOH | GTL | 17 | DC1 | LLO | 33 | ! | 49 | 1 | 65 | A | 81 | Q | 97 | a | 113 | q |
| 2 | STX | | 18 | DC2 | | 34 | " | 50 | 2 | 66 | B | 82 | R | 98 | b | 114 | r |
| 3 | ETX | | 19 | DC3 | | 35 | # | 51 | 3 | 67 | C | 83 | S | 99 | c | 115 | s |
| 4 | EOT | SDC | 20 | DC4 | DCL | 36 | \$ | 52 | 4 | 68 | D | 84 | T | 100 | d | 116 | t |
| 5 | ENQ | PPC | 21 | NAK | PPU | 37 | % | 53 | 5 | 69 | E | 85 | U | 101 | e | 117 | u |
| 6 | ACK | | 22 | SYN | | 38 | & | 54 | 6 | 70 | F | 86 | V | 102 | f | 118 | v |
| 7 | BEL | | 23 | ETB | | 39 | ' | 55 | 7 | 71 | G | 87 | W | 103 | g | 119 | w |
| 8 | BS | GET | 24 | CAN | SPE | 40 | (| 56 | 8 | 72 | H | 88 | X | 104 | h | 120 | x |
| 9 | HT | TCT | 25 | EM | SPD | 41 |) | 57 | 9 | 73 | I | 89 | Y | 105 | i | 121 | y |
| 10 | LF | | 26 | SUB | | 42 | * | 58 | : | 74 | J | 90 | Z | 106 | j | 122 | z |
| 11 | VT | | 27 | ESC | | 43 | + | 59 | ; | 75 | K | 91 | [| 107 | k | 123 | { |
| 12 | FF | | 28 | FS | | 44 | , | 60 | < | 76 | L | 92 | \ | 108 | l | 124 | |
| 13 | CR | | 29 | GS | | 45 | - | 61 | = | 77 | M | 93 |] | 109 | m | 125 | } |
| 14 | SO | | 30 | RS | | 46 | . | 62 | > | 78 | N | 94 | ^ | 110 | n | 126 | ~ |
| 15 | SI | | 31 | US | | 47 | / | 63 | ? / UNL | 79 | O | 95 | _ | 111 | o | 127 | DEL |
| Addressed commands | | | Universal commands | | | Listener addresses | | | Talker addresses | | | Secondary addresses and commands | | | | | |

Code:

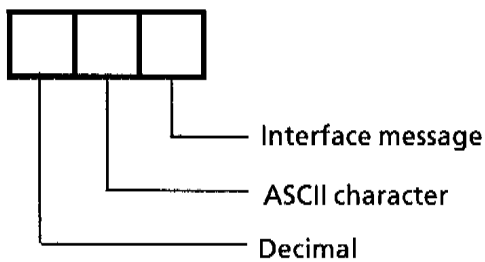

2.13.4 Device Messages

Device messages (in line with IEC 625-1) are transmitted on the data lines, in which case the Attention line is High, i.e. not active. The ASCII code (ISO 7-bit code) is used (see Table 2.13-4).

As can be seen in Table 2.13-5, the device messages can be grouped according to two different aspects.

Table 2.13-5 Grouping of device messages

| Type of commands | Direction of transfer | |
|---|------------------------------|--------------------------|
| | Messages received by the CMS | Messages sent by the CMS |
| Common device-independent commands (in line with the IEEE 488.2 standard) | cf. Table 2.13-6 | cf. Table 2.13-7 |
| Device-specific commands (dependent on the device characteristics) | cf. Table 2.13-8 | cf. Table 2.13-8 |

In the following text, device messages received by the CMS are referred to as commands.

Commands with a "?", such as "COUNT:RF?" request the CMS to output a measured value where the same format is used as in the command table. For the given example, this is:

"COUNT:RF 20 000 000",

when always the basic unit applies (Hz in this case).

Commands with a "?" and subsequent data give a specific setting value to the CMS and request the CMS to output the measured value. In the case of a search routine, this would be:

S_N:RX TEST? 20 DB

2.13.4.1 Commands Received by the CMS in Listener Mode (Controller to Device Messages)

Input buffer:

All commands received are buffered in a memory of max. 256 bytes; it is also possible to process command lines which are longer. In this case, the part of the command line which was first received is already processed in the device.

Command syntax:

Fig. 2.13-2 shows the syntax of a command line (program message). Every command line must end with a terminator.

Terminators:

- New line (ASCII code 10 decimal)
- End (EOI line active) together with the last useful character of the command line or the new line character.

Since the carriage return character (ASCII code 13 decimal) is permissible as a filler without effect before the terminator, the combination of carriage return + new line is permissible.

All IEC-bus controllers from Rohde & Schwarz send terminators accepted by the device as standard. A command line may require more than one line on the controller screen since it is only limited by the terminator. The terminator is automatically added to the end of command text with most IEC-bus controllers.

Separators:

A command line may contain several commands (program message units) separated by semicolons (;).

Command structure:

A command may consist of the following parts:

- Only a header
Example: **RST*
- Header and question mark (Query)
Example: *POWER:RF?*

This combination requests the CMS to transfer the desired data to an output buffer in order to transfer them via the IEC bus as soon as it is addressed as a Talker (see Section 2.13.4.2).

- Header and number

Examples: *FREQUENCY:RF:TXTEST 20E6*
FREQUENCY:RF:TXTEST 20 MHz

To remain in accordance with the IEEE 488.2 standard, the header and number(s) must be separated by at least one space (ASCII code 32 decimal). In the case of device-specific commands, the number can be supplemented by a unit.

- Header and string

Example: *FREQUENCY:AF:11 ON*

The headers and their meanings are explained in Sections 2.13.4.3 and 2.13.4.4.

Lower case/upper case letters:

Lower case letters are permissible and are equivalent to the corresponding upper case letters. Thus units can be used in the usual form (e.g.: dBm) instead of the notation using upper case letters which is also permissible (e.g. DBM).

Spaces:

Additional spaces may be inserted at the following points:

- before a header;
- between header and number;
- before and after commas (,) and semicolons (;)
- before the terminator.

Decimal numbers:

The following notations are permissible for decimal numbers:

- With and without sign
e. g. 5, +5, -5

- With and without decimal point, any position of decimal point is permissible.
e. g. 1.234, -100.5, .327
- With or without exponent to base 10, "E" or "e" is used as the exponent character.
e. g. .451, 451E-3, +4.51e-2
- The exponent is permissible with or without a sign, also a space is permissible instead of the sign.
e. g. 1.5E+3, 1.5E-3, 1.5E 3
- Leading zeros are permissible in the mantissa and exponent.
e. g. +0001.5, -01.5E-03
- The length of the number, including the exponent, may be up to 30 characters. The number of digits for the mantissa and exponent is only limited by this condition. Digits which exceed the resolution of the device are rounded up or down; they are always considered for the order of magnitude (power of ten).
e. g. 150000000, 0.00000032

If two numeric entries are permissible with one command, they are separated by comma, e.g. DISPLAY: MENU 2,0

Note: Specification of the exponent alone (e.g.: E-3) is not permissible, 1E-3 is correct).

Hexadecimal and binary numbers:

Hexadecimal numbers and binary numbers are permissible only without exponent and unit, the following notations are permissible:

Hexadecimal number

e.g. #H12ffab, #h12FFAB, #HFf19a

Binary number

e.g. #b101011, #B11001

String entries:

The following notations are permissible for string entries:

e.g. CODE '01234567890abcdef'
CODE '0123456789abCDEF'
CODE "01234567890abcdef"
CODE "0123456789AbcdEF"

Command line

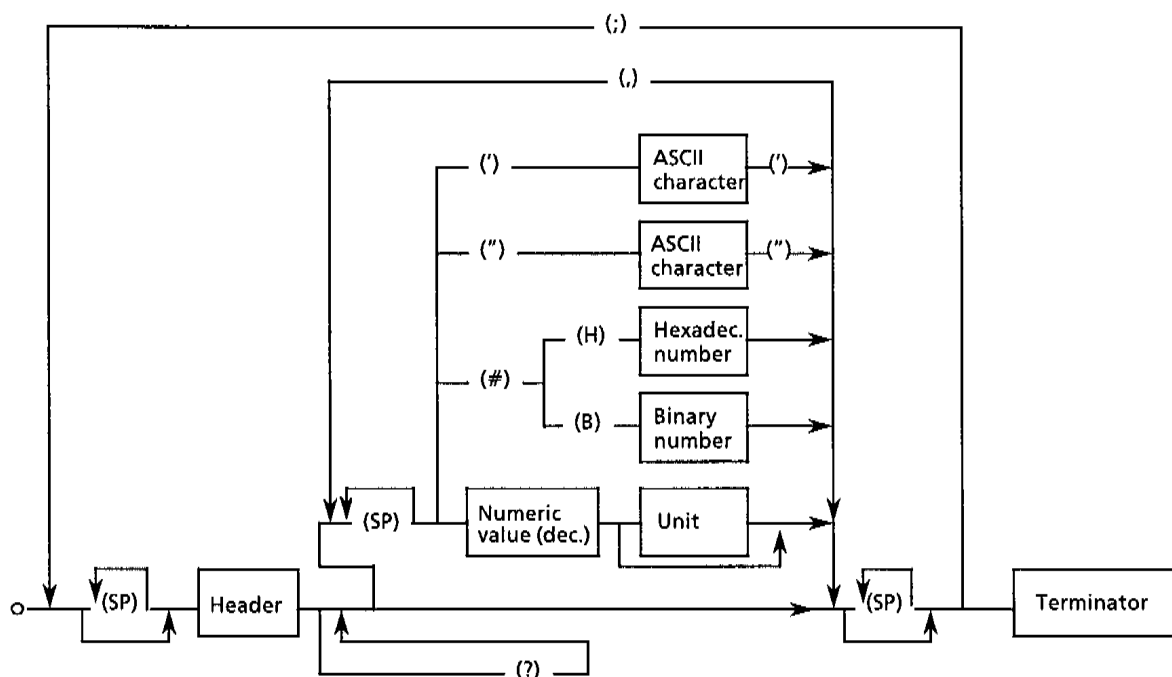

Numeric value (decimal)

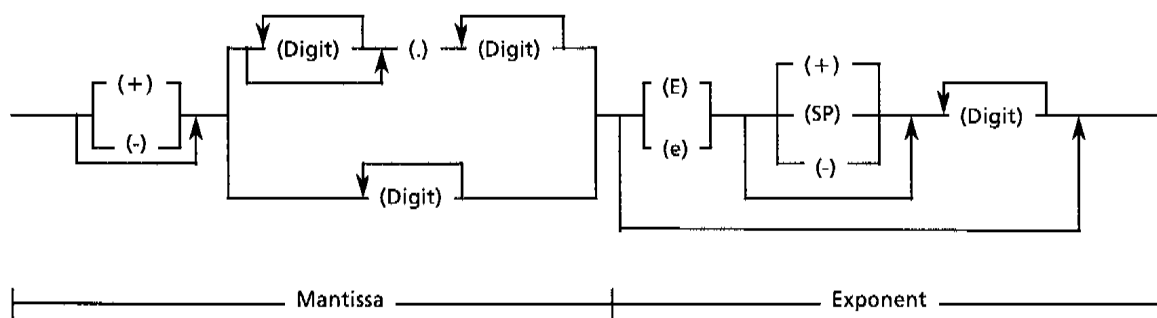

SP: Any character with ASCII code 0 to 9 and 11 to 32 decimal, especially space.

Fig. 2.13-2 Syntax diagram of a command line

2.13.4.2 Messages Sent by the CMS in Talker Mode (Device to Controller Messages)

The CMS sends messages via the IEC bus if it

- has been requested to provide data in its output buffer by one or more query messages with a question mark within one command line,
- indicates by setting bit 4 (message available) in the status byte that the requested data are now present in the output buffer (see also Section 2.13.5), and
- has been addressed as a talker

Note that the command line with the data request must be transmitted directly before the talker is addressed. If another command line is present in between, the output buffer is cleared.

The maximum length of the output buffer is 256 bytes.

A query message is formed by adding a question mark "?" onto the header of Table 2.13-8, e.g. "COUNT: RF?".

If the CMS is addressed as a Talker directly after the query message, the bus handshake is disabled until the requested data are available. This simple synchronization procedure is certainly meaningful with the CMS if the execution of a query message can take place independent of the execution and termination of a test run.

The syntax of the messages sent by the CMS is shown in Fig. 2.13-3. The syntax is similar to that for commands received by the CMS.

A new line (ASCII code 10 decimal) together with end (line EOI active) is used as terminator.

The transmission of "header and numbers" makes it possible that the messages sent by the CMS can again be returned to the CMS in the same form, without any amendments as setting commands. Thus a setting made on the keyboard can be read, stored in the controller and repeated later via the IEC bus.

- If the CMS receives several query messages, it also returns several messages within one line separated by semicolons (;).
- Several numbers can be sent as a reply to certain query messages, they are separated by commas (,).
- Header and numbers are always separated by spaces.
- Headers only consist of upper-case letters and the characters ":", "_", and "*".
- The syntax of the numbers is described in Fig. 2.13-3. The exact form of the numbers of each message is described in Tables 2.13-7 and 2.13-8.
- Messages sent by the CMS do not contain units. In the case of physical variables, the numbers are referred to the basic unit of the units specified in Table 2.13-8 (V, A, W, OHM, S, Hz, RAD, PCT, DB).

Special Cases in the Talker Mode

In the Talker mode one result is usually output. There are however the following exceptions, where several values separated by commas are output:

- Demodulation: DEMODULATION?
Two results are output. However, the second result makes only sense with peak weighting of the demodulated signal. Otherwise a zero is output as second result.
- Search Routines
In the case of all search routines two results in accordance with the following table are output.

| Search Routine | 1st Result | 2nd Result |
|------------------------|-----------------------------|------------------------------------|
| Bandwidth Measurement | Actual value of bandwidth | Actual value of delta frequency |
| Squelch | Act. value of Switch Off RF | Actual value of Squelch Hysteresis |
| Quieting | Actual value of Quiet | Actual value of RF Level |
| Sinad/Dist/SN | Actual value of Sinad/SN | Actual value of RF Level |
| Modulation Sensitivity | Nominal value of Demod | Actual value of AF Level1 |

- Read out contents of decoded telegram: DECODE:NUMBER?
The contents of the decoded telegram can be output using DECODE:NUMBER? 0 to 40. The number specifies which entry in the measurement buffer is to be output. Each entry in the buffer consists of three values:
1st Time in second
2nd Frequency in Hz
3rd Deviation in percent from the nominal value

If the decoded telegram of an acknowledgement test (CODE function, Section 2.5.4) is to be read out, commands CODE:ACKTEST ON and either CODE<transmit string> or CODE? have to precede the command DECODE:NUMBER? value.

Output message line

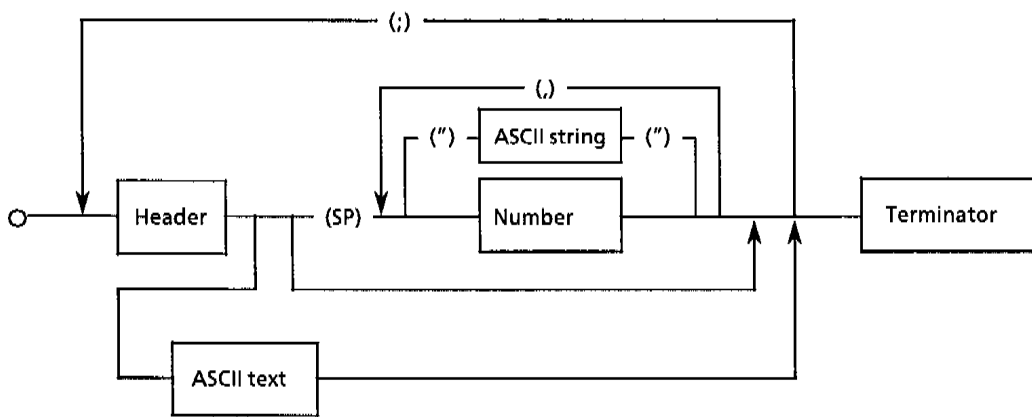

Number

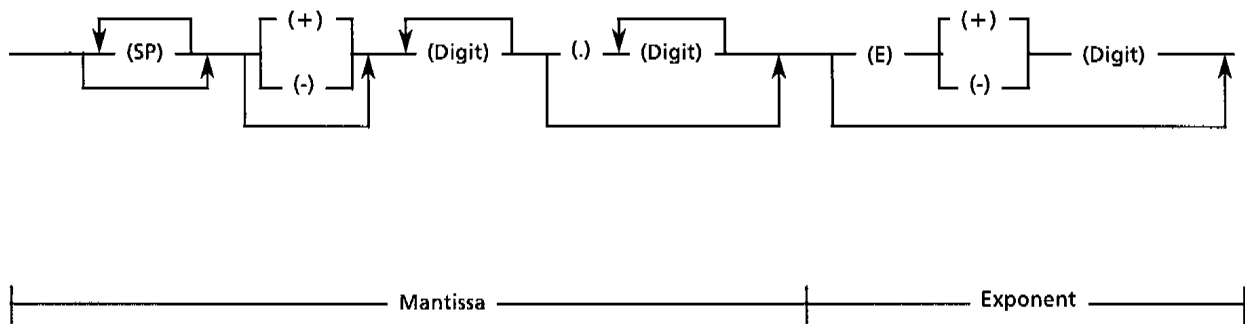

SP: Space (ASCII code 32 decimal)
 ASCII text: Reply to command *IDN? (see table 2.13-7)

Fig. 2.13-3 Syntax diagram of messages sent by the CMS

2.13.4.3 Device-independent Commands (Common Commands)

These commands are listed in Tables 2.13-6 and 2.13-7 and can be split up into the following groups:

- Commands which refer to the Service Request function with the associated status and mask registers
- Commands for device identification
- Commands which refer to the Parallel Poll function

- Commands for device-internal sequences (reset, calibrate) and for synchronizing sequences.

These are taken from the IEEE 488.2 standard, which ensures that these commands have the same effect in different devices.

The headers of these commands consist of a star (*) followed by three letters.

Table 2.13-6 Device-independent commands (common commands) received by the CMS

| Command | Number, range | Meaning |
|---------|---------------|--|
| *RST | --- | <p>Reset</p> <p>Acts on the instrument setting like the RESET key.</p> <p>This command does not change the status of the IEC-bus interface, the set IEC-bus address, the mask register of the Service Request function and the output buffer.</p> <p>A current Service Request is only reset if it has not been produced by a message in the output buffer.</p> |
| *PSc | 0 to 65535 | <p>Power On Status Clear (reset on power-up)</p> <p>If > 0: with power-up, the Service Request Enable mask register (SRE) and the Event Status Enable mask register (ESE) are cleared in addition.</p> <p>If 0: the above-mentioned registers retain their contents when the device is switched on and off. This enables a Service Request when the device is switched on.</p> |
| *OPC | --- | <p>Operation Complete (ready signal)</p> <p>Sets bit 0 (Operation Complete) in the ESR, if all previous commands have been processed (see Section 2.13.7).</p> |
| *CLS | --- | <p>Clear Status</p> <ul style="list-style-type: none"> ● Sets the status registers (ESR and STB) to zero. The mask registers of the Service Request function (ESE and SRE) are not changed. ● Clears the output buffer. <p>A present Service Request is cleared (see Section 2.13.5).</p> |
| *ESE | 0 to 255 | <p>Event Status Enable</p> <p>The ESE mask register is set to the specified value which is interpreted as a decimal number (see Section 2.13.5).</p> |
| *SRE | 0 to 255 | <p>Service Request Enable</p> <p>The SRE mask register is set to the specified value which is interpreted as a decimal number (see Section 2.13.5).</p> |

| Command | Number, range | Meaning |
|---------|---------------|--|
| *PRE | 0 to 255 | Parallel Poll Enable The Parallel Poll Enable mask register is set to the specified value which is interpreted as a decimal number (see Section 2.13.5). |
| *WAI | ---- | Wait To Continue Only process the subsequent commands when all previous commands have been completely executed (see Section 2.13.7). |

Table 2.13-7 Device-independent commands sent by the CMS

| Command | Output message Data value | | Meaning |
|---------|---------------------------|--------------|--|
| | No. of digits | Range | |
| *IDN? | 23 | alphanumeric | Identification Query The following identification text is sent via the IEC/IEEE bus as a reply to the IDN? command. Example: Rohde&Schwarz, CMS,0,X.XX Rohde&Schwarz = manufacturer CMS = model 0 = reserved for serial number, (not used with CMS) X.XX = firmware version (e.g. V1.00) |
| *PSc? | 1 | 0 or 1 | Power On Status Clear Query To read the status of the Power On Clear Flags, see *PSC in Table 2.13-6 |
| *OPC? | 1 | 1 | Operation Complete Query (ready message) The message "*OPC 1" is entered into the output buffer and bit 4 (message available) set in the status byte if all previous commands have been completely executed. Bit 0 (operation complete) is also set in the ESR (see Section 2.13.7). |
| *ESR? | 1 to 3 | 0 to 255 | Event Status Register Query The contents of the ESR are output in decimal form and the register then set to zero. |

Meaning of the CMS Option Bits Not Documented

| Bit | Meaning |
|-----|--|
| 10 | Autorun control/printer control (B15) incorporated as standard |
| 16 | VOR/ILS generator (model 57) |
| 18 | Software-dependent flag |
| 20 | Harmonics measurement |
| 21 | Software-dependent flag |
| 22 | At least 50 MHz span in RF spectrum |
| 24 | Software-dependent flag |
| 27 | RF count via RF IN2 |
| 28 | Software-dependent flag |
| 29 | For future applications |
| 33 | Software-internal flag |
| 34 | Have-Quick (special software required) |
| 35 | RDKS (special version of software required) |

2.13.4.4 Device-specific Commands

All CMS functions which can be set using the keyboard can also be controlled via the IEC bus. The effect of the setting commands is the same as the corresponding entry via the keyboard.

According to the output in the display, the values of all setting parameters can also be read out via the IEC bus, especially the marker frequency and marker level values.

Table 2.13-8 shows the setting commands and the data request commands with the associated messages sent by the CMS.

The headers are the same as the key designations or similar to them. This results in easy-to-read (self-documenting) programs.

The headers can be abbreviated by omitting any characters at the end. The shortest possible notation is shown in Table 2.13-8 in bold print.

Many headers consist of several parts separated by colons (:). The abbreviations can be used in each part of the header (e.g. FR:R:TX instead of FREQUENCY:RF:TXTEST).

Certain headers contain the underline character (ASCII code 95 decimal) to facilitate reading.

All setting commands which must be assigned values are listed in Table 2.13-8 in the column "Data". Certain commands may also have a character string as the data, e.g. FREQUENCY:RF:TXTEST ON.

A unit can be added directly to the numbers in the setting commands. The permissible units are listed in Table 2.13-8. They may also be abbreviated and written with lower-case or upper-case letters. If no unit is used, the respective default unit applies (V, A, OHM, S, HZ, RAD, PCT, DB).

Table 2.13-8 Device-specific setting commands

IEC-bus commands for common device functions

| Command | Data | Units | Function |
|--|-------------------|-------|---|
| X:VARIATION | no. ON OFF | --- | Step size of set values |
| X:REFERENCE | no. ON OFF | --- | Measured or set value becomes reference |
| X:TOLERANCE:UPPER X:TOLERANCE:LOWER | no. ON OFF | --- | Output of tolerance markers in the analog display |
| X:RANGE | no. ON OFF | --- | Full-scale value of analog display |

X corresponds to any command, e. g. "COUNT:RF".

| Command | Data | Units | Function |
|-----------|------|------------------------|--|
| X: | --- | <desired display unit> | Conversion of the display unit for the CMS display |

| Command | Data | Units | Function |
|--|---|-------|---|
| RESET | --- | --- | Reset to original state |
| PRESET | --- | --- | Reset to a defined state |
| STORE:STATE | number (1-3) | --- | Storing of device state |
| STORE:FREQUENCY | number (10-29) | --- | Storing of RF frequency |
| RECALL:STATE | number (1-3) | --- | Recall of device state |
| RECALL:FREQUENCY | number (10-29) | --- | Recall of RF frequency |
| HARDCOPY DISPLAY:MENU | --- | --- | Hardcopy of screen contents |
| | number number | --- | Direct selection of a menu. The first number selects the main menu, the second number the associated submenu (see table below). |
| HEADER | ON OFF | --- | Output of the IEC-bus header is switched on or off. |
| UNIT | --- | --- | Set unit |
| LANGUAGE | ENGLISH DEUTSCH ITALIAN FRENCH SPANISH | --- | Language selection |

| Main menu | | Submenu | | | |
|-----------|-----------------|---------|------------------|-------|-----------------------|
| Index | Name | Index | Name | Index | Name |
| 0 | Selection menu | 0 | no submenu | 20 | RX-CODE 1 |
| 1 | TX-Test menu | 1 | TX-SET-RF 1 | 21 | RX-CODE 2 |
| 2 | RX-Test menu | 2 | TX-POWER 1 | 22 | RX-FILTER 1 |
| 3 | Duplex-Test | 3 | TX-COUNT | 23 | RX-FILTER 2 |
| 4 | TONES menu | 4 | ACP1 (ACP) | 24 | RX-SINAD |
| 5 | TONES AF1/AF2 | 5 | ACP2 (HARMONICS) | 25 | RX-S/N |
| 6 | SPECTRUM menu | 6 | DEMODO | 26 | RX-MOD 1 |
| 7 | CONFIG menu | 7 | TX-AF-COUNT | 27 | Reserved |
| 13 | SELF-CHECK menu | 8 | DECODE1 | 28 | CONFIG-Search-Routine |
| 14 | CR-SEL menu | 9 | DECODE2 | 29 | TX-POWER 2 (VSWR) |
| 15 | CR main menu | 10 | TX-FILTER 1 | 30 | CONFIG-Control |
| 16 | Modem menu | 11 | TX-FILTER 2 | 66 | VOR/ILS-SCOPE |
| 17 | VOR | 12 | DISTORTION | 67 | Settling |
| 18 | ILS-LOC | 13 | TX-S/N | 68 | Reserved |
| 19 | ILS-GS | 14 | TX-INPUT | 69 | SSB-TX-FILTER 2 |
| 20 | Marker Beacon | 15 | TX-SCOPE | 70 | SSBTX-AF COUNT |
| 21 | R232 | 16 | CODE-CDCSS | 71 | Have-Quick-Rollover |
| 22 | R232 Config. | 17 | RX-RF-LEVEL | 72 | TX-SET-RF2 |
| 25 | ERMES | 18 | RX-AF-LEVEL | | |
| 26 | SSB-TX-Test | 19 | RX-AF-COUNT | | |
| 27 | SSB-RX-Test | | | | |
| 28 | Audio-I / F | | | | |
| 29 | Have-Quick | | | | |
| 30 | RDKS | | | | |

IEC-bus commands for TX and RX test

| Command | Data | Units | Function |
|-------------------------------|------------|------------|--|
| FREQUENCY:RF:TXTEST | no. | MHZ KHZ HZ | RF frequency input in TX-Test |
| FREQUENCY:RF:TXTEST | ? | MHZ KHZ HZ | Query of the setting |
| FREQUENCY:RF:TXTEST:VARIATION | no. ON OFF | MHZ KHZ HZ | |
| FREQUENCY:RF:TXTEST:REFERENCE | no. ON OFF | MHZ KHZ HZ | |
| FREQUENCY:RF:RXTEST | no. | MHZ KHZ HZ | RF frequency input in TX-Test |
| FREQUENCY:RF:RXTEST | ? | MHZ KHZ HZ | Query of the setting |
| FREQUENCY:RF:RXTEST:VARIATION | no. ON OFF | MHZ KHZ HZ | |
| FREQUENCY:RF:RXTEST:REFERENCE | no. ON OFF | MHZ KHZ HZ | |
| FREQUENCY:RF:TRANSFER | ON OFF | --- | Channel numbering |
| FREQUENCY:RF:DUPLEXSPACE | no. | MHZ KHZ HZ | |
| FREQUENCY:RF:REFCHANNEL | no. | --- | |
| FREQUENCY:RF:CHANNELSPACE | no. | MHZ KHZ HZ | |
| FREQUENCY:RF:NUMBERING | ON OFF | --- | |
| FREQUENCY:AF:I1 | no. ON OFF | MHZ KHZ HZ | AF frequency of modulation generator 1 |
| FREQUENCY:AF:I1 | ? | MHZ KHZ HZ | Query of the setting |
| FREQUENCY:AF:I1:VARIATION | no. ON OFF | MHZ KHZ HZ | |
| FREQUENCY:AF:I1:REFERENCE | no. ON OFF | MHZ KHZ HZ | |

| Command | Data | Units | Function |
|--|--------------------|-------------------|--|
| FREQUENCY:AF:I2 | no. ON OFF | MHZ KHZ HZ | AF frequency of modulation generator 2 |
| FREQUENCY:AF:I2 | ? | MHZ KHZ HZ | Query of the setting |
| FREQUENCY:AF:I2:VARIATION | no. ON OFF | MHZ KHZ HZ | |
| FREQUENCY:AF:I2:REFERENCE | no. ON OFF | MHZ KHZ HZ | |
| COUNT:RF | no. | MHZ KHZ HZ | Counting of RF frequency |
| COUNT:RF | ? | MHZ KHZ HZ | < Measured value > |
| COUNT:RF:REFERENCE | no. ON OFF | MHZ KHZ HZ | |
| COUNT:RF:TOLERANCE:UPPER | no. ON OFF | MHZ KHZ HZ | |
| COUNT:RF:TOLERANCE:LOWER | no. ON OFF | MHZ KHZ HZ | |
| COUNT:RF:PRESET | no. ON OFF | MHZ KHZ HZ | Presetting RF frequency for counting |
| COUNT:RF:DIRECTCOUNT | no. ON OFF | MHZ KHZ HZ | Direct coarse RF counting |
| COUNT:RF:TRANSFER | --- | --- | Transfer of counted frequency as working frequency |
| COUNT:AF:TXTEST | no. | MHZ KHZ HZ | Counting of AF frequency in TX-Test |
| COUNT:AF:TXTEST | ? | MHZ KHZ HZ | < Measured value > |
| COUNT:AF:TXTEST:REFERENCE | no. ON OFF | MHZ KHZ HZ | |
| COUNT:AF:TXTEST:SOURCE | DEMOD BEAT | --- | Selection of Demod or Beat |
| COUNT:AF:TXTEST:TOLERANCE:LOWER | ON OFF | MHZ KHZ HZ | |
| COUNT:AF:TXTEST:TOLERANCE:UPPER | ON OFF | MHZ KHZ HZ | |
| COUNT:AF:TXTEST:PERIOD | PERIOD GATE | --- | Operating mode of AF counter |
| COUNT:AF:RXTEST | no. | MHZ KHZ HZ | Counting the AF frequency of the AF voltmeter |
| COUNT:AF:RXTEST | ? | MHZ KHZ HZ | < Measured value > |
| COUNT:AF:RXTEST:REFERENCE | no. ON OFF | MHZ KHZ HZ | |
| COUNT:AF:RXTEST:TOLERANCE:LOWER | ON OFF | MHZ KHZ HZ | |
| COUNT:AF:RXTEST:TOLERANCE:UPPER | ON OFF | MHZ KHZ HZ | |
| COUNT:AF:RXTEST:PERIOD | PERIOD GATE | --- | Operating mode of the AF counter |

| Command | Data | Units | Function |
|-------------------------------------|-----------------------|--------------|------------------------------------|
| POWER:RF | --- | W DBM | Power measurement |
| POWER:RF | ? | W DBM | < Measured value > |
| POWER:RF:TOLERANCE:UPPER | no. ON OFF | W DBM | |
| POWER:RF:TOLERANCE:LOWER | no. ON OFF | W DBM | |
| POWER:RF:REFERENCE | no. ON OFF | W DBM | |
| POWER:RF:RANGE | no. ON OFF | W DBM | |
| POWER:RF:TIME | AUTO FAST SLOW | --- | Measurement speed |
| POWER:RF:HOLD | ON OFF | --- | Hold function |
| POWER:RF:RESET | --- | --- | Basic setting |
| POWER:RF:PEP | ON OFF | --- | |
| POWER:RF:FORWARD | --- | W DBM | Selection of unit |
| POWER:RF:FORWARD | ? | W DBM | < Measured value > |
| :TOLERANCE:LOWER | no. ON OFF | W DBM | |
| :TOLERANCE:UPPER | no. ON OFF | W DBM | |
| POWER:RF:FORWARD:RANGE | no. ON OFF | W DBM | |
| POWER:RF:FORWARD:REFERENCE | no. ON OFF | W DBM | |
| POWER:RF:REFLECTED | --- | W DBM | Selection of unit |
| POWER:RF:REFLECTED | ? | W DBM | < Measured value > |
| :TOLERANCE:LOWER | no. ON OFF | W DBM | |
| :TOLERANCE:UPPER | no. ON OFF | W DBM | |
| POWER:RF:REFLECTED:RANGE | no. ON OFF | W DBM | |
| POWER:RF:REFLECTED:REFERENCE | no. ON OFF | W DBM | |
| POWER:RF:VSWR | ? | --- | < Non-dimensional measured value > |
| :TOLERANCE:LOWER | ON OFF | --- | |
| :TOLERANCE:UPPER | ON OFF | --- | |

| Command | Data | Units | Function |
|----------------------|--|--------------------------|--|
| ACP | --- | V Mv Uv W DBUv DBM DB | Selection of unit |
| ACP | ? | V Mv Uv W DBUv DBM DB | <Measured value> |
| ACP:TOLERANCE:LOWER | no. ON OFF | V Mv Uv W DBUv DBM DB | Setting lower tolerance markers for adjacent channel measurement |
| ACP:TOLERANCE:UPPER | no. ON OFF | V Mv Uv W DBUv DBM DB | Setting upper tolerance markers for adjacent channel measurement |
| ACP:RANGE | no. ON OFF | V Mv Uv W DBUv DBM DB | Selecting measurement range |
| ACP:ADJACENT:CHANNEL | PLUS _ 2 PLUS _ 1 MINUS _ 1 MINUS _ 2 | --- | Selection of channel for the first/second and upper/lower adjacent channel |
| ACP:CHANNELSPACE | SEL _ 25KHZ SEL _ 20KHZ SEL _ 12 _ 5KHZ SEL _ 10KHZ | --- | Selecting specific channel spacings |
| ACP:FILTER | ON OFF SEL _ 16KHZ SEL _ 14KHZ SEL _ 8 _ 5KHZ | --- | Filter selection when choosing any channel spacing |
| ACP:FREECHANNEL | no. ON OFF | MHZ KHZ HZ | Selecting any channel spacing |
| ACP:HARM:FIRST | --- | --- | The harmonic which will be measured is determined by selecting one of these four commands. |
| ACP:HARM:SECOND | --- | --- | |
| ACP:HARM:THIRD | --- | --- | |
| ACP:HARM:FOURTH | --- | --- | |

| Command | Data | Units | Function |
|-------------------------------------|--|---------------------------|---|
| DEMODULATION | no. | PCT MHZ KHZ HZ RAD | Selection of demodulation type DEMOM measurement and search routine |
| DEMODULATION | ? | PCT MHZ KHZ HZ RAD | < Measured value > |
| DEMODULATION:TOLERANCE:UPPER | no. ON OFF | PCT MHZ KHZ HZ RAD | |
| DEMODULATION:TOLERANCE:LOWER | no. ON OFF | PCT MHZ KHZ HZ RAD | |
| DEMODULATION:RANGE | no. ON OFF | PCT MHZ KHZ HZ RAD | |
| DEMODULATION:REFERENCE | no. ON OFF | PCT MHZ KHZ HZ RAD | |
| DEMODULATION:DEEMPHASIS | NORMAL SEL-750 | --- | Deemphasis: no deemphasis or 750 μ s |
| DEMODULATION:WEIGHTING | AUTO PK RMS RMS $\sqrt{2}$ PK2 | --- | Weighting: peak, RMS RMS: $\sqrt{2}$, average of pos. and negative peak |
| DEMODULATION:AVERAGING | SEL-1 SEL-2 SEL-3 SEL-4 | --- | Averaging |
| DEMODULATION:CONTROL | SQUELCH ON OFF | --- | Demodulation: Squelch on, off |
| PEAKHOLD | no. | PCT MHZ KHZ HZ RAD | Selection of demodulation mode and retaining max. value |
| PEAKHOLD | ? | PCT MHZ KHZ HZ RAD | < Measured value > |
| PEAKHOLD:TOLERANCE:UPPER | no. ON OFF | PCT MHZ KHZ HZ RAD | |
| PEAKHOLD:TOLERANCE:LOWER | no. ON OFF | PCT MHZ KHZ HZ RAD | |
| PEAKHOLD:REFERENCE | no. ON OFF | PCT MHZ KHZ HZ RAD | |
| PEAKHOLD:RANGE | no. ON OFF | PCT MHZ KHZ HZ RAD | |

| Command | Data | Units | Function |
|-----------------------------------|-------------------------------|-------------------|--|
| DECODE | --- | --- | Decoding of selective call |
| DECODE | ? | --- | Received value |
| DECODE:STANDARD | no. | --- | Selection of standard (see Section 2.4.4) |
| DECODE:DIGITREPEAT | ON OFF | --- | Digit repeat |
| DECODE:BANDWIDTH | no. | PCT | Evaluation bandwidth |
| DECODE:PAUSE | no. | S Ms Us | Tolerable pause |
| DECODE:SOURCE | DEMOD AFVOLT | --- | Selection of source |
| DECODE:NUMBER | no. | --- | Tone number |
| CODE | String | --- | Transmitting of selective call |
| CODE | ? | --- | Query of the string |
| CODE:STANDARD | no. | --- | Selection of standard (see Section 2.4.4) |
| CODE:MSGREPEAT | no. | --- | Number of telegrams to be transmitted |
| CODE:REPEATTONE | ON OFF | --- | Tone repetition |
| CODE:ACKTEST | ON OFF RF_OFF | --- | Acknowledgement test |
| CODE:FR.TUNE | no. | PCT | Frequency deviation |
| CODE:SPECIAL:NUMBER | no. | --- | Selection of extra tone |
| CODE:SPECIAL:LENGTH | no. | S Ms Us | Length of extra tone |
| CODE:OTHER:LENGTH | no. | S Ms Us | Duration of other tones |
| CODE:DIGITPAUSE | no. | S Ms Us | Time elapsing between the tones |
| CODE:MSGPAUSE | no. | S Ms Us | Time elapsing between the telegrams |
| CODE:RESET | --- | --- | Resetting the original parameters |
| FILTER:TXTEST | ON OFF | --- | Switching on/off the selected filters in TX-Test |
| FILTER:TXTEST:HP | ON OFF | --- | High pass filter in TX-Test |
| FILTER:TXTEST:LP | ON OFF | --- | Low pass filter in TX-Test |
| FILTER:TXTEST:PSOPHOMETRIC | ON OFF | --- | Psophometric filter in TX-Test |
| FILTER:TXTEST:NOTCH | no. ON OFF | MHZ KHZ HZ | Notch filter in TX-Test |
| FILTER:TXTEST:RESONANCE | no. ON OFF | MHZ KHZ HZ | Resonance filter in TX-Test |
| FILTER:TXTEST:EXTERNAL | ON OFF | --- | External filter in TX-Test |
| FILTER:TXTEST:IF | WIDE NARROW | --- | IF filter |

| Command | Data | Units | Function |
|-------------------------------------|--|--------------------------|---|
| FILTER:RXTEST | ON OFF | --- | Switching on/off the selected filters in RX-Test |
| FILTER:RXTEST:HP | ON OFF | --- | High pass filter in RX-Test |
| FILTER:RXTEST:LP | ON OFF | --- | Low pass filter in RX-Test |
| FILTER:RXTEST:PSOPHOMETRIC | ON OFF | --- | Psophometric filter in RX-Test |
| FILTER:RXTEST:NOTCH | no. ON OFF | MHZ KHZ HZ | Notch filter in RX-Test |
| FILTER:RXTEST:RESONANCE | no. ON OFF | MHZ KHZ HZ | Resonance filter in RX-Test |
| FILTER:RXTEST:EXTERNAL | ON OFF | --- | External filter in RX-Test |
| ATTENUATION:IF | ON OFF AUTO | --- | Attenuation of IF control |
| DISTORTION:TXTEST | no. | PCT MHZ KHZ HZ DB | Distortion measurement of demodulated signal |
| DISTORTION:TXTEST | ? | PCT MHZ KHZ HZ DB | < Measured value > |
| :TOLERANCE:UPPER | no. ON OFF | PCT MHZ KHZ HZ DB | |
| :TOLERANCE:LOWER | no. ON OFF | PCT MHZ KHZ HZ DB | |
| :RANGE | no. ON OFF | PCT MHZ KHZ HZ DB | |
| DISTORTION:TXTEST:AFCOUPLED | ON OFF | --- | The frequency of the modulation generator is identical with the distortion measurement frequency. |
| DISTORTION:TXTEST:AVERAGING | SEL _1 SEL _2 SEL _3 SEL _4 | --- | Averaging |
| DISTORTION:RXTEST | no. | PCT MHZ KHZ HZ DB | Distortion measurement of the signal applied to the AF voltmeter |
| DISTORTION:RXTEST | ? | PCT MHZ KHZ HZ DB | < Measured value > |
| :TOLERANCE:UPPER | no. ON OFF | PCT MHZ KHZ HZ DB | |
| :TOLERANCE:LOWER | no. ON OFF | PCT MHZ KHZ HZ DB | |
| :RANGE | no. ON OFF | PCT MHZ KHZ HZ DB | |
| SINAD:RXTEST | no. | PCT MHZ KHZ HZ DB | SINAD measurement of the signal applied to the AF voltmeter |
| SINAD:RXTEST | ? | PCT MHZ KHZ HZ DB | < Measured value > |
| SINAD:RXTEST:TOLERANCE:UPPER | no. ON OFF | PCT MHZ KHZ HZ DB | SINAD search routine |
| SINAD:RXTEST:TOLERANCE:LOWER | no. ON OFF | PCT MHZ KHZ HZ DB | |
| SINAD:RXTEST:RANGE | no. ON OFF | PCT MHZ KHZ HZ DB | |
| SINAD_DISTORTION:AFCOUPLED | ON OFF | --- | The frequency of the modulation generator is identical with the meas. frequ. |
| SINAD_DISTORTION:AVERAGING | SEL _1 SEL _2 SEL _3 SEL _4 | --- | Averaging |
| SINAD_DISTORTION:WINDOW | no. | PCT DB | Window of SINAD search routine |
| SINAD_DISTORTION:WINDOW | ? | PCT DB | Query of the setting |

| Command | Data | Units | Function |
|-----------------------------------|------------------------------------|-----------------------|---|
| S_N:TXTEST | no. | PCT DB | S/N measurement of demodulated signal |
| S_N:TXTEST | ? | PCT DB | <Measured value> |
| S_N:TXTEST:TOLERANCE:UPPER | no. ON OFF | PCT DB | |
| S_N:TXTEST:TOLERANCE:LOWER | no. ON OFF | PCT DB | |
| S_N:TXTEST:RANGE | no. ON OFF | PCT DB | |
| S_N:TXTEST:GEN2 | USED UNUSED | --- | 2nd modulation generator is also used for S/N meas. |
| S_N:TXTEST:AVERAGING | SEL_1 SEL_2 SEL_3 SEL_4 | --- | Averaging |
| S_N:RXTEST | no. | PCT DB | S/N meas. of the signal applied to the AF voltm. |
| S_N:RXTEST | ? | PCT DB | <Measured value> |
| S_N:RXTEST:TOLERANCE:UPPER | no. ON OFF | PCT DB | S/N search routine |
| S_N:RXTEST:TOLERANCE:LOWER | no. ON OFF | PCT DB | |
| S_N:RXTEST:RANGE | no. ON OFF | PCT DB | |
| S_N:RXTEST:EXTERNAL | USED UNUSED | --- | External modulation is also used |
| S_N:RXTEST:AVERAGING | SEL_1 SEL_2 SEL_3 SEL_4 | --- | Averaging |
| S_N:RXTEST:GEN2 | USED UNUSED | --- | 2nd modulation generator is also used |
| S_N:RXTEST:WINDOW | no. | PCT DB | Window of SINAD search routine |
| S_N:RXTEST:WINDOW | ? | PCT DB | Query of the setting |
| INPUT:ONE | no. | DB | Selection of input and external attenuation |
| INPUT:TWO | no. | DB | Selection of input and external attenuation |
| INPUT:TWO:ATTENUATION | SEL_0DB SEL_24DB | | Set the attenuation |
| LEVEL:RF | no. ON OFF | MV UV DBUV DBM | Level setting of RF synthesizer |
| LEVEL:RF | ? | MV UV DBUV DBM | Query of the setting |
| LEVEL:RF:VARIATION | no. ON OFF | V MV UV DB | |
| LEVEL:RF:REFERENCE | no. ON OFF | MV UV DBUV DBM | |
| LEVEL:RF:FINE | no. ON OFF | MV UV DBUV DBM | Level sett. via fine level var. |
| LEVEL:RF:BANDWIDTH | --- | --- | Bandwidth measurement |
| LEVEL:RF:SQUELCH | --- | --- | Squelch routine |
| LEVEL:RF:QUIETING | no. | DB | Quieting measurement |
| LEVEL:RF:RXTEST:LEVEL | PD EMF | --- | Level output |

| Command | Data | Units | Function |
|--|---|---------------------------|---|
| LEVEL:AF:I1 | no. ON OFF | V Mv Uv DBUv DBM | Level setting of first modulation generator |
| LEVEL:AF:I1 | ? | V Mv Uv DBUv DBM | Query of the setting |
| LEVEL:AF:I1:VARIATION | no. ON OFF | V Mv Uv Db | |
| LEVEL:AF:I1:REFERENCE | no. ON OFF | V Mv Uv DBUv DBM | |
| LEVEL:AF:I2 | no. ON OFF | V Mv Uv DBUv DBM | Level setting of second modulation generator |
| LEVEL:AF:I2 | ? | V Mv Uv DBUv DBM | Query of the setting |
| LEVEL:AF:I2:VARIATION | no. ON OFF | V Mv Uv Db | |
| LEVEL:AF:I2:REFERENCE | no. ON OFF | V Mv Uv DBUv DBM | |
| LEVEL:AF:RXTEST | no. | V Mv Uv W DBUv DBM | Level setting of AF voltmeter |
| LEVEL:AF:RXTEST | ? | V Mv Uv W DBUv DBM | Query of the setting |
| LEVEL:AF:RXTEST:TOLERANCE:UPPER | no. ON OFF | V Mv Uv W DBUv DBM | |
| LEVEL:AF:RXTEST:TOLERANCE:LOWER | no. ON OFF | V Mv Uv W DBUv DBM | |
| LEVEL:AF:RXTEST:REFERENCE | no. ON OFF | V Mv Uv W DBUv DBM | |
| LEVEL:AF:RXTEST:RANGE | no. ON OFF | V Mv Uv W DBUv DBM | |
| LEVEL:AF:RXTEST:WEIGHTING | PLUS-PK MINUS-PK RMS RMS_SQRT2 | --- | Weighting the AF voltmeter: pos. peak, neg. peak, RMS, RMS · √2, average of pos. and neg. peak |
| LEVEL:AF:RXTEST:AVERAGING | SEL 1 SEL _2 SEL _3 SEL _4 | --- | Averaging |
| LEVEL:AF:RXTEST:COUPLING | AC DC3HZ DCWIDE | --- | Cut-off frequency of the AF voltmeter |
| LEVEL:AF:RXTEST:ATTENUATION | AUTO ON OFF | --- | Internal attenuator |
| MODE:TXRX:LOCK | ON OFF | --- | LOCK function |
| MODULATION:AF:I1 | no. ON OFF | PCT MHZ KHZ HZ RAD | Modulation of the RF signal generator with the first modulation generator |
| MODULATION:AF:I1 | ? | PCT MHZ KHZ HZ RAD | Query of the setting |
| MODULATION:AF:I1:VARIATION | no. ON OFF | PCT MHZ KHZ HZ RAD | |
| MODULATION:AF:I1:REFERENCE | no. ON OFF | PCT MHZ KHZ HZ RAD | |

| Command | Data | Units | Function |
|-----------------------------------|-------------------|---------------------------|--|
| MODULATION:AF:I2 | no. ON OFF | PCT MHZ KHZ HZ RAD | Modulation of the RF signal generator with the second modulation generator |
| MODULATION:AF:I2 | ? | PCT MHZ KHZ HZ RAD | Query of the setting |
| MODULATION:AF:I2:VARIATION | no. ON OFF | PCT MHZ KHZ HZ RAD | |
| MODULATION:AF:I2:REFERENCE | no. ON OFF | PCT MHZ KHZ HZ RAD | |
| MODULATION:EXTERNAL | no. ON OFF | PCT MHZ KHZ HZ | External modulation of the RF signal generator |
| MODULATION:EXTERNAL | ? | PCT MHZ KHZ HZ | Query of the setting |
| :VARIATION | no. ON OFF | PCT MHZ KHZ HZ | |
| :REFERENCE | no. ON OFF | PCT MHZ KHZ HZ | |
| :CALIBRATION | --- | --- | Modulation: ext. calibration |
| :VOLTAGE | no. | V MV UV | Input of external modulation voltage |
| MODULATION:COUPLING | AC DC | --- | Set the coupling |
| MODULATION:OFF | --- | --- | |
| DC:VOLTAGE | no. | MV V | DC voltage measurement |
| DC:VOLTAGE | ? | MV V | < Measured value > |
| DC:VOLTAGE:REFERENCE | no. ON OFF | MV V DB | |
| DC:VOLTAGE:RANGE | no. ON OFF | MV V DB | |
| DC:VOLTAGE:TOLERANCE:UPPER | no. ON OFF | MV V DB | |
| DC:VOLTAGE:TOLERANCE:LOWER | no. ON OFF | MV V DB | |
| DC:CURRENT | no. | MA A | DC current measurement |
| DC:CURRENT | ? | MA A | < Measured value > |
| DC:CURRENT:REFERENCE | no. ON OFF | MA A DB | |
| DC:CURRENT:RANGE | no. ON OFF | MA A DB | |
| DC:CURRENT:TOLERANCE:UPPER | no. ON OFF | MA A DB | |
| DC:CURRENT:TOLERANCE:LOWER | no. ON OFF | MA A DB | |

IEC-bus-commands for the SCOPE mode

| Command | Data | Units | Function |
|---------------------------------|--|--------------------------------------|---|
| SCOPE:CONTINUE | ON OFF | --- | ON: Activation of the scope OFF: FREEZE mode |
| SCOPE:CONTINUE:AUTO | --- | --- | Automatic selection of source |
| SCOPE:CONTINUE:SOURCE | MODEXT DEMOD-BEAT AF DIST | --- | Defined selection of source |
| SCOPE:BESTRANGE | ON OFF | --- | Selection of best measuring range |
| SCOPE:AMPLITUDE | no. | --- | Amplitude setting |
| SCOPE:TIME | no. | --- | Time setting |
| SCOPE:YPOSITION | no. | --- | Y position |
| SCOPE:PROBE:RF | no. ON OFF | V Mv Uv DBUv DBM | Selection of unit and external attenuation, switches measurement on/off |
| SCOPE:PROBE:RF | ? | V Mv Uv DBUv DBM | < Measured value > |
| SCOPE:PROBE:RF:REFERENCE | --- | V Mv Uv DBUv DBM Db | |
| :TOLERANCE:LOWER | --- | V Mv Uv DBUv DBM Db | |
| :TOLERANCE:UPPER | --- | V Mv Uv DBUv DBM Db | |
| SCOPE:PROBE:RF:RANGE | --- | V Mv Uv DBUv DBM Db | |
| SETTLING:ARM | ON OFF | --- | |
| SETTLING:MODE | POWER FREQUENCY | --- | |
| SETTLING:MARKER | no. ON OFF | --- | |
| SETTLING:TIME | no. ON OFF | --- | |
| SETTLING:AMP | no. ON OFF | --- | |

IEC-bus commands for selective call generation

| Command | Data | Units | Function |
|--|--|--|--|
| TONES:STANDARD | no. | --- | Calling of standard (see Section 2.10) |
| TONES:RESET | no. | --- | Resetting of original parameters |
| TONES:SPECIAL:NUMBER | no. | --- | Selection of extra tone |
| TONES:SPECIAL:LENGTH | no. | S Ms Us | Duration of extra tone |
| TONES:OTHER:LENGTH | no. | S Ms Us | Duration of other tones |
| TONES:DIGITPAUSE | no. | S Ms Us | Time elapsing between the tones |
| TONES:COUPLING:STANDARDS | COUPLED INDEPENDENT | --- | Coupling of standards |
| TONES:DECODE:TIME | no. | S Ms Us | Decoding time |
| TONES:SELECT:FREQUENCY:ONE | --- | --- | Selection of tones for generator 1 |
| TONES:SELECT:FREQUENCY:TWO | --- | --- | Selection of tones for generator 2 |
| TONES:TONE0 TONES:TONE1 TONES:TONE2 TONES:TONE3 TONES:TONE4 TONES:TONE5 TONES:TONE6 TONES:TONE7 TONES:TONE8 TONES:TONE9 TONES:TONEA TONES:TONEB TONES:TONEC TONES:TONED TONES:TONEE TONES:TONEF | no. no. no. no. no. no. no. no. no. no. no. no. no. no. no. no. | MHZ KHZ HZ MHZ KHZ HZ MHZ KHZ HZ MHZ KHZ HZ MHZ KHZ HZ MHZ KHZ HZ MHZ KHZ HZ MHZ KHZ HZ MHZ KHZ HZ MHZ KHZ HZ MHZ KHZ HZ MHZ KHZ HZ MHZ KHZ HZ MHZ KHZ HZ MHZ KHZ HZ MHZ KHZ HZ | Assignment of tones to frequencies |
| TONES:AF:I10 TONES:AF:I11 TONES:AF:I12 TONES:AF:I13 TONES:AF:I14 TONES:AF:I15 TONES:AF:I16 TONES:AF:I17 TONES:AF:I20 TONES:AF:I21 TONES:AF:I22 TONES:AF:I23 TONES:AF:I24 TONES:AF:I25 TONES:AF:I26 TONES:AF:I27 | no. no. no. no. no. no. no. no. no. no. no. no. no. no. no. no. | MHZ KHZ HZ MHZ KHZ HZ MHZ KHZ HZ MHZ KHZ HZ MHZ KHZ HZ MHZ KHZ HZ MHZ KHZ HZ MHZ KHZ HZ MHZ KHZ HZ MHZ KHZ HZ MHZ KHZ HZ MHZ KHZ HZ MHZ KHZ HZ MHZ KHZ HZ MHZ KHZ HZ MHZ KHZ HZ | Assignment of tones to frequencies for standard 0 (variation series for modulation generators 1 and 2) |

IEC-bus commands for SSB

| Command | Data | Units | Function |
|-------------------------------|---|-----------------------------|---|
| SSB:LEVEL:I1 | --- | V Mv Uv DBUv DBM | RF output level |
| SSB:LEVEL:I1:VARIATION | --- | V Mv Uv DB | |
| SSB:LEVEL:I1:REFERENCE | --- | V Mv Uv DBUv DBM | |
| SSB:LEVEL:I2 | --- | V Mv Uv DBUv DBM | RF output level |
| SSB:LEVEL:I2:VARIATION | --- | V Mv Uv DB | |
| SSB:LEVEL:I2:REFERENCE | --- | V Mv Uv DBUv DBM | |
| SSB:MODE | SEL_SSB_LSB SEL_SSB_USB SEL_SSB_CW | --- | Selection of the RF offset |
| SSB:STATUS | ON OFF | --- | Switches the SSB transmission mode on/off |

IEC-bus commands for the self-test

| Command | Data | Units | Function |
|--|---------------|-------|--|
| CALIBRATION:CYCLIC | ON OFF | --- | Cyclic calibration |
| CALIBRATION:DISTORTION | --- | --- | Distortion calibration |
| CALIBRATION:DETECTOR:RMS | --- | --- | Calibration of RMS detector |
| CALIBRATION:MODULATION:FILTER | --- | --- | Calibration of AF synthesizer filters |
| CALIBRATION:MODULATION: GENERATOR | --- | --- | Calibration of offset and amplitude of the AF synthesizers |
| CALIBRATION:POWER | --- | --- | Calibration of power meter |
| CALIBRATION:PEAK | --- | --- | Calibration of peak meter |
| CALIBRATION:SYNTHESIZER | --- | --- | Calibration of synthesizer deviation |
| SERVICE:BATTERY | ON OFF | --- | Battery voltage measurement |

IEC-bus commands for configuration

| Command | Data | Units | Function |
|---|---------------------------------------|---------------------|--|
| CONFIGURATION:AF:TRANSFORMER | | SEL_600_OHM | NORMAL |
| CONFIGURATION:R_REFERENCE | no. | OHM | Reference resistance of AF voltmeter |
| CONFIGURATION:KEYBEEP | ON OFF | --- | Acoustic key acknowledgement |
| CONFIGURATION:WARNING | ON OFF | --- | Warning in case of erroneous operation |
| CONFIGURATION:ZOOM | ON OFF | --- | |
| CONFIGURATION:CLOCK:EXTERNAL | ON OFF | --- | Switching to ext. reference |
| CONFIGURATION:PRINTER:TYPE | NECP6,7 EPSON PDN CM-Z22 | --- | Printer type |
| CONFIGURATION:SCREEN:LIGHTING | ON OFF SEL_5_MIN SEL_1_H | --- | Lighting of the CMS is switched on/off or switched on for 5/60 min |
| CONFIGURATION:ROUTINE:LIMIT:TIMEOUT | no. | S Ms Us | Timeout value for search routines |
| CONFIGURATION:ROUTINE:LIMIT:DELAY | no. | S Ms Us | Wait time for slowing down the test cycle with squelch measurement |
| CONFIGURATION:ROUTINE:LIMIT:THRESHOLD | no. | Mv Uv W DBUv DBM | AF level (measurement): threshold value for squelch on/off |
| CONFIGURATION:ROUTINE:LIMIT:AF LEVEL | no. | Mv Uv W DBUv DBM | Upper AF level limit for search routines |
| CONFIGURATION:ROUTINE:LIMIT:RF LEVEL | no. | Mv Uv W DBUv DBM | Upper RF level limit for search routines |
| CONFIGURATION:ROUTINE:LIMIT:MEASURE | no. | S Ms Us | Measuring time |
| CONFIGURATION:ROUTINE:LIMIT:ATTACKTIME | no. | S Ms Us | Wait time until meas. start |
| CONFIGURATION:CONTROL:TTL | no. | --- | Input and/or output of the TTL interfaces |
| CONFIGURATION:CONTROL:TTL | ? | --- | <Received value> |
| CONFIGURATION:CONTROL:TTL:VARIATION | no. | --- | |
| CONFIGURATION:CONTROL:RELAYS | no. | --- | Programming of the relays |
| CONFIGURATION:CONTROL:RELAYS: :VARIATION | no. | --- | |
| CONFIGURATION:CONTROL:INOUT | IN_IN IN_OUT OUT_IN OUT_OUT | --- | Programming of the TTL interface |
| CONFIGURATION:CONTROL:RX TX | ON OFF | --- | Setting most significant relays via RX - TX switchover |
| CONFIGURATION:LO:HIGH | ON OFF | --- | LO frequency |

IEC-bus commands for the SPECTRUM operation

| Command | Data | Units | Function |
|---|--|-------------------------------------|--|
| SPECTRUM:ATTENUATION SPECTRUM:AUTOATTENUATION | no. | DB | <Attenuation dB> |
| SPECTRUM:FILTER | SEL_150HZ SEL_6KHZ SEL_16KHZ SEL_50KHZ SEL_300KHZ SEL_1MHZ SEL_3MHZ | | |
| SPECTRUM:TRACKING SPECTRUM:TRACKING:OFFSET SPECTRUM:TRACKING:OFFSET | ON OFF no. ? | MHZ KHZ HZ | (only if CMS-B9/-B59 is fitted) <OffsetFreq Hz> " <Query of the setting> |
| SPECTRUM:QUICK | ON OFF | | |
| SPECTRUM:CABLE:FAULT | no. ON OFF | | <Cable fault test, shortening fault> |
| SPECTRUM:CENTER SPECTRUM:CENTER | no. ? | MHZ KHZ HZ | <CenterFreq Hz> <Query of the setting> |
| SPECTRUM:SPAN SPECTRUM:SPAN | no. ? | MHZ KHZ HZ | <SpanFreq Hz> <Query of the setting> |
| SPECTRUM:START SPECTRUM:START | no. ? | MHZ KHZ HZ | <StartFreq Hz> <Query of the setting> |
| SPECTRUM:STOP SPECTRUM:STOP | no. ? | MHZ KHZ HZ | <StopFreq Hz> <Query of the setting> |
| SPECTRUM:REFERENCE:LEVEL | no. | V Mv Uv W DBUv DBM | <RefLevel W> |
| SPECTRUM:REFERENCE:LEVEL | ? | V Mv Uv W DBUv DBM | <Query of the setting> |
| SPECTRUM:SCALE | SEL_2DB SEL_5DB SEL_10DB | | |
| SPECTRUM:FREEZE | ON OFF | | |
| SPECTRUM:MARKER SPECTRUM:MARKER SPECTRUM:MARKER:REFERENCELEVEL SPECTRUM:MARKER: CENTERFREQUENCY | no. ? ON OFF ON OFF | MHZ KHZ HZ | --- <MKr Level W> <MkrFreq Hz> |

IEC-bus commands for options *)

| Command | Data | Units | Function |
|----------------------------------|--|-------------------------------|--|
| MODEM | OFF ENTER | --- | Switch on FFSK transmitter |
| MODEM:ZERO:FREQUENCY | no. | MHZ kHz Hz | Frequency which results in a log of 0 |
| MODEM:ONE:FREQUENCY | no. | MHZ kHz Hz | Frequency which results in a log of 1 |
| MODEM:BIT:FREQUENCY | no. | --- | Transmission speed |
| MODEM:MODULATION | no. ON OFF | MHZ kHz Hz | Deviation setting |
| MODEM:LEVEL | no. ON OFF | V Mv Uv W DBUv DBM | Output level |
| MODEM:SQUELCH | no. | DB | |
| MODEM:IO:LEVEL | TTL RS232 | --- | Selection of the modulation sensitivity |
| MODEM:SLOPE | RISE FALL | --- | |
| SERIAL:NULINE | AUTO CR CRLF OFF | --- | Selection of string terminator |
| SERIAL:RX:TIMEOUT | no. | --- | Waiting period in ms after reception of the last character until abortion of the SEND function |
| SERIAL:RX:DISABLE | ON OFF | --- | Disabling reception of data |
| SERIAL:PARITY | OFF SEL_0 SEL_1 EVEN ODD | --- | Selection of parity bit with transmission and reception |
| SERIAL:BAUD:RATE | SEL_19 200 BD SEL_9 600 BD SEL_4 800 BD SEL_2 400 BD SEL_12 00 BD SEL_6 00 BD SEL_3 00 BD SEL_15 0 BD | --- | Setting the baud rate |
| SERIAL:ECHO:CANCEL | ON OFF | --- | Activating/Deactivating the ECHO CANCEL function |
| SERIAL:BITS | SEL_8_1 SEL_8_2 SEL_7_1 SEL_7_2 | --- | Determination of the data format for transmission |
| SERIAL:SEND | no. ON OFF | --- | Send string via the serial interface |
| SERIAL:SEND:IMMEDIATELY | ON OFF | --- | Setting: Send individual characters |
| SERIAL:SOFTWARE:HANDSHAKE | OFF ETX_ACK XON_XOFF | --- | Selection of software-handshake protocol |
| SERIAL:HARDWARE:HANDSHAKE | OFF SEL_2_WIRE SEL_4_WIRE | --- | Selection of hardware-handshake protocol |

*) depending on model or option

| Command | Data | Units | Function |
|--------------------------------------|---|-------|--|
| CDCSS:TURN_OFF | ON OFF SEL_100 MS SEL_150 MS SEL_200 MS SEL_250 MS | --- | |
| CDCSS:TRANSM_END | SEL_100 MS SEL_150 MS SEL_200 MS SEL_250 MS SEL_300 MS SEL_350 MS SEL_400 MS | --- | |
| AUDIO_IF:CONNECTION | SEL_UNBALAN SEL_BALAN | --- | Set the connection |
| AUDIO_IF:INPUT:AF | TEL_1 TEL_2 | --- | Input selection |
| AUDIO_IF:IMPED:BALANCED | SEL_150_OHM SEL_300_OHM | | Only with SEL_BALAN |
| AUDIO_IF:IMPED:MEAS | ON OFF | OHM | Measure the load impedance |
| AUDIO_IF:IMPED:MEAS | ? | OHM | < Measured value > |
| :TOLERANCE:LOWER | no. ON OFF | --- | |
| :TOLERANCE:UPPER | no. ON OFF | --- | |
| AUDIO_IF:IMPED:MEAS:RANGE | no. ON OFF | --- | |
| AUDIO_IF:IMPED:MEAS:REFERENCE | no. ON OFF | --- | |
| AUDIO_IF:IMPED:MATCH | ON OFF | --- | Match the voltage to the last IMPED result |

Function Keyboard Lock

The CMS permits to lock the keyboard using an IEC-bus command. This serves to prevent an unauthorized user from intervening in the measurement or changing preset parameters.

The IEC-bus command for locking the keyboard reads as follows:

```
"KEYBOARD:LOCK ON".
```

The following message appears in the first status line:

```
"REMOTE with Lockout"
```

If an IEC-interface command (goto local - GTL) is used to switch to manual operation, the keyboard is locked as well. The message

```
"CMS - Local with Lockout"
```

is displayed in the first status line.

This state permits observing measurement sequences (e.g. with zoom function activated) at the display without settings at the CMS being able to be changed.

This state can only be canceled by sending the unlocking command via the IEC-bus controller or by switching off/on the CMS.

The IEC-bus command for unlocking the keyboard reads as follows:

```
"KEYBOARD:LOCK OFF".
```

The following message appears in the first status line:

```
"REMOTE-Local by <STOP>".
```

Remark: After switching on the CMS, the keyboard is always unlocked.

Setting Units

The IEC-bus command "UNIT<unit>" makes it possible to select the unit of the results which are sent from the CMS to the controller. The CMS attempts to convert each result into the selected unit. If this is not possible, the result is returned in the default IEC unit. The command "UNIT" remains valid until it is cancelled with "UNIT NO_UNIT".

The unit used by the CMS to display the results can be changed by sending the command, followed by the desired unit.

Example:

```
"POWER: RF DBM"
```

2.13.5 Service Request and Status Registers

The following Fig. shows the status registers and the effective links between them. To remain in accordance with the IEEE 488.2 standard, the Status Byte (STB) and its associated mask register (SRE), which are also present with older devices, have been supplemented by the Event Status Register (ESR) and its Event Status Enable Mask Register (ESE).

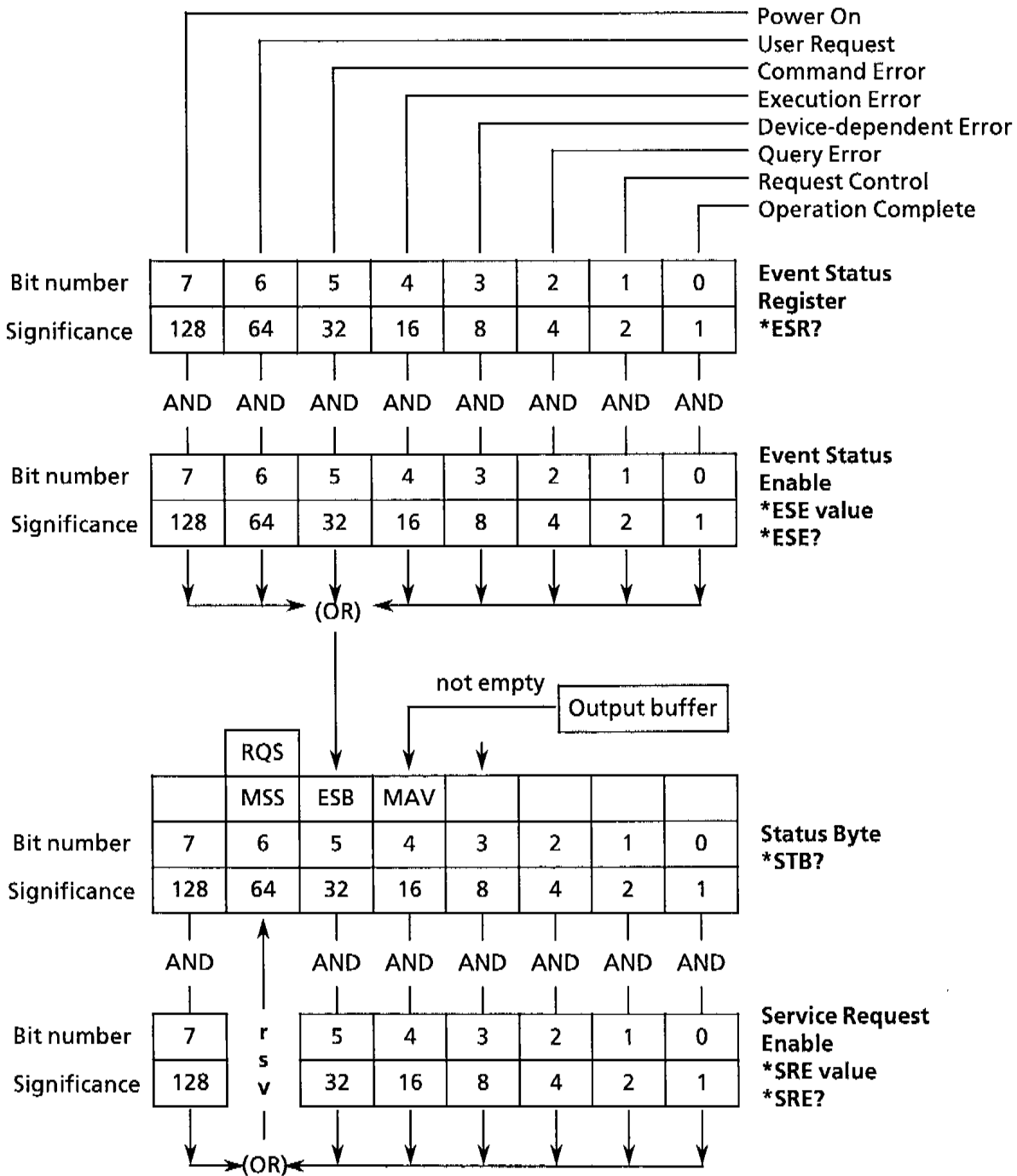

Fig. 2.13-4 Status registers

A bit is set to "1" in the ESR in the case of certain events (e.g. fault, ready signal), see Table 2-13-10. These bits remain set until they are cleared by reading the ESR (by the command *ESR?) or by the following conditions:

- The commands *RST or *CLS
- Switching on the AC supply (the power-on bit is, however, set in this case).

Using the ESE mask register, the user can select the bits in the ESR which also set the sum bit ESB (bit 5 in the status byte) via which a service request can be triggered. The sum bit is therefore only set if at least one bit in the ESR and the corresponding bits in the ESE are set to "1". The sum bit is automatically cleared again if the previous condition is no longer fulfilled, e.g. if the bits in the ESR have been cleared by reading the ESR or if the ESE has been modified.

The ESE mask register is written by the command "*ESE value" ("value" is the contents in decimal form) and can be read again by the command *ESE?. It is set to "0" when the AC power is switched on if the power on status clear flag is "1" (*PSC1). The ESE mask register is not changed by other commands or interface messages (DCL, SDC).

The bits listed in Table 2.13-9 are used in the status byte (STB):

Table 2-13-9 Bit allocation of status byte

| Bit number | Bus line | Designation | Meaning |
|------------|----------|-------------|--|
| 4 | DIO 5 | MAV | Message Available Indicates that a message, which can be read, is present in the output buffer. The bit is "0" if the output buffer is empty. |
| 5 | DIO 6 | ESB | Sum bit of the Event Status Register |
| 6 | DIO 7 | RQS | Request Service |

Note that the status register bits are numbered from 0 to 7 in compliance with the standard, but the bus data lines are designated DIO1 to DIO8.

Table 2.13-10 Bit allocation of ESR

| Bit Number | Meaning |
|------------|--|
| 7 | <p>Power On</p> <p>Is set when the instrument is switched on or if the power returns following a failure.</p> |
| 6 | <p>User Request</p> <p>This function is not implemented in the CMS.</p> |
| 5 | <p>Command Error</p> <p>Is set if one of the following faults is detected in the received commands:</p> <ul style="list-style-type: none"> ● Syntax error ● Illegal unit ● Illegal header ● A number has been combined with a header where no number is allowed. |
| 4 | <p>Execution Error</p> <p>Is set if one of the following errors was detected during execution of the received commands</p> <ul style="list-style-type: none"> ● A number is outside the permissible range (for the respective parameter). ● A received command is not compatible with the current device setting. |
| 3 | <p>Device-dependent Error</p> <p>Is set if functional errors occur.</p> |
| 2 | <p>Query Error</p> <p>This bit is set:</p> <ul style="list-style-type: none"> ● If the controller wishes to read data from the CMS but no query message has previously been output. ● If the data present in the output buffer of the CMS have not been read out and a new command was sent to the instrument instead. The output buffer is cleared in this case. |
| 1 | <p>Request Control</p> <p>This function is not implemented in the CMS.</p> |
| 0 | <p>Operation Complete</p> <p>This bit is set by the commands *OPC and *OPC? if all previous commands have been executed.</p> |

Using the SRE mask register, the user can determine whether the ESB, and/or MAV bits of the status byte are set, and whether a Service Request is sent to the controller by activating the SRQ line. Since each bit in the SRE mask register is assigned to the corresponding bit in the status byte, the following possibilities result (see Table 2.13-11), and the combinations thereof.

Table 2.13-11 Bit allocation of the SRE

| Contents of SRE (decimal) | Set bit No. in SRE | Effect |
|---------------------------|--------------------|--|
| 0 | -- | No Service Request |
| 16 | 4 | Service Request if MAV bit is set (message in output buffer) |
| 32 | 5 | Service Request if ESB bit is set (at least 1 bit set and not masked in the ESR) |

The Service Request Enable mask register (SRE) is written by the command `"*SRE value"` ("value" is the contents in decimal form) and can be read again by the command `*SRE?`. It is set to "0" when the AC power is switched on, if the power-on clear flag is "1"; the Service Request function of the CMS is thus disabled. The SRE mask register is not changed by other commands or interface messages (DCL, SDC).

Several devices can trigger a Service Request simultaneously, the open collector drivers generate an OR function on the SRQ line. The controller must read the status bytes of the devices in order to identify the device which has triggered the Service Request. A set RQS bit (bit 6/DIO7) indicates that the device is sending a Service Request.

The status byte of the CMS can be read in the following manner:

- By the command `*STB?`.

The contents are then output in decimal form. The status byte is not changed by reading out, and the Service Request is not cleared.

- By a Serial Poll.

The contents are transferred in binary form as one byte. The RQS bit is then set to "0" and the Service Request becomes inactive; the other bits of the status byte are not changed.

The status byte is cleared:

- By the command `*CLS`.

This command clears the ESR and the output buffer; the ESB and MAV bits in the status byte are also set to "0". This in turn clears the RQS bit and the Service Request.

- By reading the ESR (`*ESR?` command) or setting the ESE mask register to "0" (`*ESE` command) and by reading the contents of the output buffer.

2.13.6 Resetting of Device Functions

The following table lists the various commands and events which cause individual device functions to be reset.

Table 2.13-12 Resetting of various device functions

| Event | Power on | | DCL, SDC (Device Clear, Selected Device Clear) | Commands | |
|---|---------------------|-----|--|----------|------|
| | Power-on-clear flag | | | *RST | *CLS |
| | 0 | 1 | | | |
| Basic device setting | -- | -- | -- | Yes | -- |
| Set Event Status Register ESR to zero | Yes | Yes | -- | Yes | Yes |
| Set mask registers ESE and SRE to zero | -- | Yes | -- | -- | -- |
| Clear output buffer | Yes | Yes | Yes | -- | Yes |
| Clear Service Request | Yes | 1) | 2) | 3) | Yes |
| Reset command processing and input buffer | Yes | Yes | Yes | -- | -- |

1) Yes, but "Service Request on power on" is possible.

2) Yes, if only caused by message in output buffer.

3) Yes, if not caused by message in output buffer.

2.13.7 Command Processing Sequence and Synchronization

The commands received by the CMS are first stored in an input buffer which can accommodate up to 256 characters. Once the terminator has been received, the commands are processed in the sequence in which they were sent. During this time, the IEC bus can be used for communication with other devices. Command lines which exceed the capacity of the input buffer are processed in several sections. The bus is occupied during this time.

OPERATION COMPLETE:

The commands *OPC and *OPC? (operation complete) are used as feedbacks to inform on the time at which processing of the received commands was terminated and a measurement (if any) has been completely performed.

*OPC sets bit 0 in the ESR, and a Service Request can then be triggered if all previous commands have been executed.

*OPC? additionally provides a message in the output buffer and sets bit 4 (MAV) in the status byte.

WAIT:

The synchronization can be established within a command line by the command "*WAI", i.e. all subsequent commands are only executed when the previous commands have been completely executed. This may be favourable in the case of very short measuring times.

Program example:

A program example of an RF counter measurement is given in the following, where a Service Request is triggered in the case of error. The type of error generated is specified in detail.

(The command set of the IEC-bus controllers PCA is used; the IEC bus address of the CMS has been taken as 24.)

```
10 IEC TERM 10 : REM input terminator LF
20 ON SRQ1 GOSUB 300
30 IEC OUT 24, "*CLS; *ESE 60; *SRE 32"
40 REM
50 REM _____ for Service Request in case
60 REM of error
70 IEC OUT 24, "HEADER ON" : REM header output as well
80 REM
90 IEC OUT 24, "DISPLAY: ME 1,0" : REM TX-Test menu
100 REM
110 IEC OUT 24, "COUNT : RF?" : REM counting of RF
120 IEC IN 24, HFCOUNT$
130 PRINT HFCOUNT$
140 END
300 REM _____
310 REM SERVICE REQUEST ROUTINE
320 REM _____
330 IEC SPL 24,S% : REM Serial Poll
340 IF (S% AND 64)=0 THEN GOTO 420 : REM SRQ not from CMS?
350 IEC OUT 24, "*ESR?" : REM Event Status Register
360 IEC IN 24, X$ : REM read
370 B=VAL(X$)
380 IF (B AND 032) <>0 THEN PRINT "COMMAND ERROR"
390 IF (B AND 016) <>0 THEN PRINT "EXECUTION ERROR"
400 IF (B AND 008) <>0 THEN PRINT "DEVIVE DEPENDENT ERROR"
410 IF (B AND 004) <>0 THEN PRINT "QUERY ERROR"
420 ON SRQ1 GOSUB 300
430 RETURN
500 REM _____
510 REM SERVICE REQUEST FROM OTHER DEVICE
520 REM _____
530 REM....
540 REM....
620 ON SRQ1 GOSUB 300
630 RETURN
```

2.13.8 Error Handling

All errors detected by the CMS in connection with operation via the IEC bus are indicated in the ESR by setting a bit (bit 2, 4 or 5, see Table 2.13-10). Function faults are signalled by setting of bit 3. These bits remain set until the ESR is read or is cleared by the commands *RST or *CLS. This is in line with the standard IEEE 488.2 and enables triggering of a Service Request and program-controlled evaluation of the type of error.

2.14 Self-Test

| | | | |
|---|----------------------------|--------|-----------------|
| 0 | SELFCHK CMS - Local | | 8 |
| 1 | PEAK CAL | 3.75 v | BATTERY CHECK 9 |
| 2 | RMS CAL | | CYCL CAL 10 |
| 3 | DIST CAL | | 11 |
| 4 | POWER CAL | | 12 |
| 5 | MODGEN ADJUST | | 13 |
| 6 | MODGEN FILTER | | 14 |
| 7 | SYNTH CAL | | 15 |

Fig. 2.14-1 Main menu SELFCHK (self-test)

Starting with the main menus of the selection menu, the main menu SELF CHK (self-test) is reached by pressing the softkey SELFCHK. Several internal measuring facilities are checked and evaluated.

2.14.1 Calibration of PEAK Meter

PEAK CAL Function

The PEAK meter in the CMS is adjusted by pressing the softkey PEAK CAL.

2.14.2 Calibration of RMS Meter

RMS CAL Function

The RMS meter in the CMS is adjusted by pressing th softkey RMS CAL.

2.14.3 Calibration of Distortion Meter

DIST CAL Function

The RMS meter of the distortion meter / SINAD meter is adjusted by pressing the softkey DIST CAL.

2.14.4 Power Calibration

POWER CAL Function

This test can be carried out only if the RF IN/OUT socket 29 is free.

The POWER CAL softkey is pressed for once adjusting the offset for power measurement at the respective measuring facilities.

2.14.5 Calibration of Modulation Generator

MODGEN ADJUST Function

An offset adjustment of the modulation generator output voltage is carried out by pressing the softkey MODGEN ADJUST.

The following text "MOD GEN adjust completed? <ENTER>" is read out in the status line.

A hardware offset adjustment (see CMS Service Manual) can then be internally performed in the instrument.

When the ENTER key is pressed, the measurement of the respective calibration data is carried out.

2.14.6 Adjustment of the Modulation Generator Filter

MODGEN FILTER Function

The frequency response caused by the output filters of the modulation generator is adjusted using the softkey MODGEN FILTER.

2.14.7 Synthesizer Calibration

SYNTH CAL Function

The deviation of the signal generator in the CMS is adjusted by pressing the softkey SYNTH CAL. This procedure takes some seconds and is output in the status line when completed.

2.14.8 Battery Check

BATT CHECK Function

The softkey BATT CHECK is pressed for once measuring the battery of the RAM with backup. The result is displayed next to the softkey, the evaluation is read out in the status line.

2.14.9 Cyclic Calibration

CYCL CAL Function

The following measuring facilities or generator functions are calibrated cyclically by pressing the softkey CYCL CAL: modulation generator offset, RMS meter, peak-value meter and A/D converter.

If measuring sequences are required at a defined point in time (especially in automatic operation), this function should better be switched off in order to prevent that asynchronous calibration measurements interfere with the time scale.

2.14.10 Limits of Calibration Values

| Calibration | Calibration value | Min. | Max. | Unit |
|---------------|---|-------|-------|------|
| PEAK CAL | Output offset | - 20 | + 20 | mV |
| | Gain | 0.9 | 1.1 | ./. |
| | Input offset | | | |
| | (Path AF AC) | - 30 | + 30 | mV |
| | (Path Demod) | - 30 | + 30 | mV |
| | (Path Dist) | - 30 | + 30 | mV |
| | (Path Psoph) | - 30 | + 30 | mV |
| | (Path Hp) | - 30 | + 30 | mV |
| RMS CAL | (Path Lp Demod) | - 30 | + 30 | mV |
| | (Path Lp AF AC) | - 30 | + 30 | mV |
| | Output offset | - 20 | + 20 | mV |
| | Gain | 0.9 | 1.1 | ./. |
| | Input offset | | | |
| | (Path AF AC) | - 50 | + 50 | mV |
| | (Path Demod) | - 50 | + 50 | mV |
| | (Path Dist) | - 50 | + 50 | mV |
| DIST CAL | (Path Psoph) | - 50 | + 50 | mV |
| | (Path Hp) | - 50 | + 50 | mV |
| POWER CAL | (Path Lp Demod) | - 50 | + 50 | mV |
| | (Path Lp Af AC) | - 50 | + 50 | mV |
| MODGEN ADJUST | Offset | - 40 | + 40 | mV |
| | Gain | 0.9 | 1.1 | ./. |
| MODGEN FILTER | Offset | - 20 | + 20 | mV |
| | Amplitude | - 270 | + 270 | mV |
| | Min/max filter Correction value at internal modulation (GEN) | 4152 | 7118 | ./. |
| | for f > 20 kHz | | 14236 | ./. |
| SYNTH CAL | Min/max filter Correction value at MODGEN output | 4152 | 7118 | ./. |
| | for f > 20 kHz | | 14236 | ./. |
| BATT CHECK | Min/max deviation Correction value at Oscillator 1 | 5 | 254 | ./. |
| | Min/max deviation Correction value at Oscillator 2 | 5 | 254 | ./. |
| | Voltage | 3.0 | 5.0 | V |

2.14.11 Error Messages

Battery Check

- error 1 : Voltage error - falling below
- error 2 : Voltage error - exceeding
- error : General error

ADC Calibration

- error 1 : Offset error
- error 2 : Gain error
- error 3 : Offset error of DC amplifier
- error : General error

Peak Detector Calibration

- error 1 : Offset error
- error 2 : Gain error
- error 3 : Offset error in AF AC path
- error 4 : Offset error in Demod path
- error 5 : Offset error in Dist. path
- error 6 : Offset error in CCITT path
- error 7 : Offset error in Hp path
- error 8 : Offset error in Lp Demod path
- error 9 : Offset error in Lp AF AC path
- error : General error

Modgen Filter Calibration

- error 1 : Freq. response error Modgen 1 - falling below
- error 2 : Freq. response error Modgen 1 - exceeding
- error 3 : Freq. response error Modgen 2 - falling below
- error 4 : Freq. response error Modgen 2 - exceeding
- error : General error

Modgen Generator Calibration

- error 1 : Offset error
- error 2 : Amplitude error
- error : General error

RMS Detector Calibration

- error 1 : Offset error
- error 2 : Gain error
- error 3 : Offset error in AF AC path
- error 4 : Offset error in Demod path
- error 5 : Offset error in Dist path
- error 6 : Offset error in CCITT path
- error 7 : Offset error in Hp path
- error 8 : Offset error in Lp Demod path
- error 9 : Offset error in Lp AF AC path
- error : General error

Distortion Detector Calibration

- error 1 : Offset error
- error 2 : Gain error
- error : General error

Power Meter Calibration

- error 1 : Offset error - exceeding
- error 2 : Offset error - falling below
- error : General error

RF-Synthesizer Deviation Calibration

- error 1 : Deviation corr. value Osc. 1 - falling below
- error 2 : Deviation corr. value Osc. 1 - exceeding
- error 3 : Deviation corr. value Osc. 2 - falling below
- error 4 : Deviation corr. value Osc. 2 - exceeding
- error : General error

3 Maintenance

3.1 Electrical Maintenance

The self-test initiated in the CMS each time it is switched on informs the user on the occurrence of any faults.

Various calibration routines can be started in the self-check menu. Calibration routines and self-tests which do not lead to an error message indicate that no errors are detected and the CMS functions properly.

The user may request readout of the battery voltage in the self-check menu to know exactly when the batteries need be replaced.

Readjustment of the reference frequency is recommended once a year (for adjustment see section 4 in the CMS Service Manual).

3.2 Mechanical Maintenance

No mechanical maintenance is required under normal operating conditions.

3.3 Storage

A storage temperature between - 40 and + 70 °C is allowed. It should be noted that storage at high temperatures reduces the service life of the batteries. Before starting operation of the instrument again the battery charge should be checked (self-check menu).



ROHDE & SCHWARZ

Bilder
Figures
Figures



ROHDE & SCHWARZ

Test and
Measurement Division

Autorun Printer Control

Printed in the Federal
Republic of Germany

Contents

| | Page |
|--|------|
| Autorun Control | 5 |
| | |
| 1 Generation of Programs on the CMS | 5 |
| 1.1 Insertion of Additional Program Lines | 9 |
| 1.2 Clearing and Shifting of Command Lines | 10 |
| 1.3 Adding Comments in the Program | 12 |
| 1.4 Delays and Stops in the Active Program Run | 13 |
| 1.5 Repetitions of Program Sections | 15 |
| 1.6 Conditional Statements in the Program | 18 |
| 1.6.1 Conditional Execution of Program Sections | 19 |
| 1.7 Printer Control during the Program Run | 22 |
| 1.7.1 Printing of Reports | 23 |
| 1.7.2 Report Formats | 24 |
| | |
| 2 Execution of Programs | 25 |
| 2.1 Parameters for Program Execution | 25 |
| 2.1.1 Report Header | 26 |
| 2.1.2 Report Formats | 26 |
| 2.1.3 Target Address of Report | 26 |
| 2.1.4 STOP Conditions | 26 |
| 2.1.5 Delays in the Program | 26 |
| 2.1.6 Initialization of the Printer | 27 |
| 2.1.7 Form Feed of the Printer | 27 |
| 2.1.8 Clearing of the Printer Buffer (SPOOLER CLEAR) | 27 |
| 2.2 Program Suspensions | 27 |
| | |
| 3 Management of Programs and Test Reports | 28 |
| 3.1 Dealing with Programs and Reports from Memory Card | 28 |
| 3.2 Linking of Programs | 28 |
| 3.3 Storing of Programs and Reports | 28 |
| 3.4 Display of Directory | 28 |
| 3.5 Display and Printing of Programs or Reports | 29 |
| 3.6 Clearing of Programs and Reports | 29 |
| 3.7 Password protection of programs | 29 |

List of Figures

| | | |
|--------|--------------------------|----|
| Fig. 1 | Main menu AUTOTEST | 5 |
| Fig. 2 | Submenu AUTOEDIT | 7 |
| Fig. 3 | Submenu ALPHA | 12 |
| Fig. 4 | Submenu SPEC-1 | 13 |
| Fig. 5 | Submenu SPEC-2 | 19 |
| Fig. 6 | Submenu AUTORUN | 25 |

Autorun Control

Note: The electronic components on the memory card are insensitive to discharge pulses, only when R&S cards with protective sheathing are used.

The Autorun Control in the CMS Radiocommunication Service Monitor allows the user to store and execute program sequences entered via front panel controls and to generate test reports printed out on an external printer. Battery-backed memory cards (CMS-Z1 etc.) serve as program library and storage media for test reports.

Menu structure:

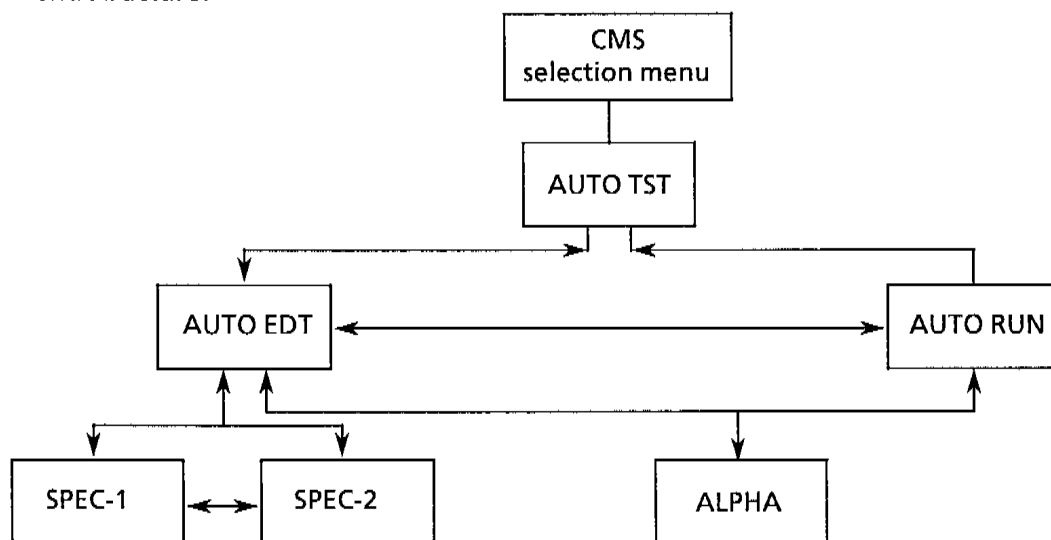

1 Generation of Programs on the CMS

Actuation of softkey 1 in the CMS selection menu calls the main menu AUTOTEST (see Fig. 1).

| | | | | |
|---|--------------------|---|---------------------------|----|
| 0 | AUTOEDT | AUTOTST CMS - Local | AUTORUN | 8 |
| 1 | SELECT | PROG-INT 11008 4 PROG-CARD 21576 50 REPORT 0 0 OTHER 0 4 FREE INT 1456 FREE CARD 8432 | | 9 |
| 2 | DIR | 0000: PROGRAM 50 0001: -----*****TEST TACS CLASSE 2*****----- 0002: ----- 0003: -----TEST AMBIENTE OPERATIVO E-TACS----- 0004: ----- 0005: -----REGISTRAZIONE----- | DELETE | 10 |
| 3 | PRINT | | FORMAT | 11 |
| 4 | TYPE | 0006: SPECIAL: PRINT: OFF 0007: PRESET | PASSWD PROTECT | 12 |
| 5 | COPY ← MEMCARD | 0008: DISPLAY: MENU 01.00 0009: INPUT: ONE 0.50 dB | | 13 |
| 6 | COPY → MEMCARD | 0010: DISPLAY: MENU 00.00 0011: DISPLAY: MENU 14.00 0012: CR: SEL: TACS 0013: CR: SEL: QUICK | PAGE UP | 14 |
| 7 | APPND ← MEMCARD | 0014: CR: TACS: REGIST 0015: DISPLAY: MENU 00,00 | PAGE DOWN | 15 |

Fig. 1 Main menu AUTOTEST

This menu comprises all the softkeys required for storing, loading and display of programs.

Softkey 1 selects the item that the other softkeys in this program refer to.

The TYPE and PRINT functions allow for the content of programs and reports written to the CMS display or an external printer. The latter, however, will only work as intended if a printer is connected to the CMS printer port and the correct printer type set in the CONFIG menu. The printer port is to be found on the rear of the unit (fig 2-2, 46 in the appendix of this manual's section 1).

Softkeys 5 & 6 allow Programs to be copied from and to memory-card, respectively. If the target program number is already in use, a security message will prompt for further confirmation. The password function (softkey 12) allows a further increase in security, if desired.

The APPEND function of softkey 7 allows to append memory-card programs to existing programs in CMS memory. This function is identical to softkey 5, if the target location is still unused. A more in-depth description of the COPY and APPEND commands may be found in chapter 3.

The DELETE key serves to erase the single item chosen with the SELECT softkey. Softkey 11 (FORMAT) allows to delete a whole group of items in a single, convenient step. A security prompt will ensure operation only if intended. Further security against FORMAT and DELETE commands is gained for programs under password protection; in that case the operator will be prompted for the current password before operation is resumed.

Softkey 12 of menu AUTOTEST covers the function allowing to protect internal AUTORUN programs as well as programs stored on memory-card. This is accomplished by setting individual passwords for both types of program. A password is defined by entry of a variable length string of numeric characters in the range from 1 to 60000 (an easy reminder being that valid values correspond to the maximum integer range of milliseconds in a minute). Entry is done via the numeric keypad 3 (see front view, fig 2-1 in the appendix to section 1).

Pressing softkey 0 (AUTOEDT) gives access to submenu AUTOEDIT (see Fig. 2).

| | | | | |
|---|------------------|----------------------------|-----------------|----|
| 0 | SPEC-1 | AUTOEDT CMS - Local | AUTOTST | 8 |
| 1 | COMMENT | 0000: PROGRAM 0 0001: | DELETE PROGR | 9 |
| 2 | RUTORUN | | | 10 |
| 3 | SPEC-2 | | GOTO LINE | 11 |
| 4 | | | LINE UP | 12 |
| 5 | DELETE LINE | | LINE DOWN | 13 |
| 6 | CUT BUFFER | | PAGE UP | 14 |
| 7 | INSERT BUFFER | | PAGE DOWN | 15 |

Fig. 2 Submenu AUTOEDIT

Programming is initiated by pressing the START hardkey, and the CMS switches back to the selection menu (or the menu selected last in the LEARN mode). Any command entered then and stored via hardkey STORE corresponds to one program line for the started sequential program. The individual commands are commented in the first status line as IEC bus commands. Actuation of hardkey STOP permits the user to leave the LEARN mode, i.e. programming is stopped and the CMS returns to the AUTOEDIT menu. The programmed commands are then listed in the display in the same sequence as entered. Each command line is preceded by a number.

Example: Following power-up the CMS is set to the selection menu

| | | | |
|-----------|-------|---|---------------------------------|
| AUTOTST | | → | Select Autorun Control |
| AUTOEDT | | → | Select LEARN mode |
| START | | → | Start programming |
| TX-TEST | STORE | → | Select transmitter test |
| AF1 | | → | Select AF generator 1 |
| 1 kHz | STORE | → | Frequency setting 1 kHz |
| SHIFT AF1 | | → | Select AF level generator 1 |
| 25 mV | STORE | → | Level setting 25 mV |
| DEMODO | | → | Select demodulation |
| MENU ↓ | | → | Select submenu DEMODO |
| WEIGHT | | → | Select peak weighting |
| WEIGHT | STORE | → | Select RMS weighting |
| MENU ↑ | | → | Leaving submenu DEMODO |
| COUNT | STORE | → | Select frequency count |
| POWER | STORE | → | Select power measurement |
| DEMODO | STORE | → | Select demodulation measurement |
| RX-TEST | STORE | → | Select the receiver test |
| STOP | | → | Stop programming |

Stop of programming switches the CMS back to the AUTOEDIT menu. All the commands previously entered in LEARN mode are listed in the display of the example program:

```
0000: PROGRAM 0
0001: DISPLAY:MENU          01,00
0002: FREQUENCY:AF:I1      1000.00 Hz
0003: LEVEL:AF:I1         +25000 uV
0004: DEMODULATION:WEIGHTING RMS
0005: COUNT:RF
0006: POWER:RF
0007: DEMODULATION
0008: DISPLAY:MENU          02,00
0009:
```

Line 0 always identifies the number of the program. This line is automatically inserted. A maximum of about 1200 lines is possible. The cursor is positioned in the last empty line; respectively marked lines can be deleted or additional lines be inserted.

Maximally 14 lines are read out in the display per display page. Softkeys 14 PAGE UP and 15 PAGE DOWN are used for page turning. These two functions are also available in the AUTOTEST menu using the same softkeys. The softkeys 12 LINE UP and 13 LINE DOWN permit to shift the cursor by one line, respectively. Softkey 11 GOTO LINE moves the cursor to a defined position.

To delete the complete program sequence, the softkey 9 DELETE PROGR is pressed. Before deletion, the CMS prompts the user by the message "ARE YOU SURE?", which is acknowledged for program deletion by pressing hardkey ENTER or aborted using hardkey CLEAR.

1.1 Insertion of Additional Program Lines

The user wishes to activate the lowpass filter of the CMS in the program example of previous Section 1 before performing the measurements. To this end, the cursor is shifted to the command line that is to be preceded by the additional commands (line 5 in this example). Then the hardkey START is pressed to restart programming. The CMS is switched back to the menu which was active on completion of programming or on start-up of the program sequence.

| | | |
|-----------------------|---|---|
| GOTO LINE 5 ENTER | → | Select command line to be preceded by additional commands |
| START | → | Start programming |
| TX-TEST | → | Change to transmitter test |
| FILTER | → | Activate filter selection |
| MENU ↓ | → | Select submenu FILTER 1 |
| LP 3.4 kHz STORE | → | Select lowpass filter |
| MENU ↑ | → | Leave submenu |
| STOP | → | Stop programming |

The last key actuation which stops programming resets the CMS to the AUTOEDIT menu. The display then shows the following program sequence:

```
0000: PROGRAM 0
0001: DISPLAY:MENU           01,00
0002: FREQUENCY:AF:I1       1000.00 Hz
0003: LEVEL:AF:I1           +25000 uV
0004: DEMODULATION:WEIGHTING RMS
0005: FILTER:TXTEST:LP      ON
0006: COUNT:RF
0007: POWER:RF
0008: DEMODULATION
0009: DISPLAY:MENU           02,00
0010:
```

Line 5 FILTER:TXTEST:LP ON is additionally included in the program sequence and the program has been renumbered. Lines can be inserted as long as the CMS is set to LEARN mode. The cursor is not shifted in this case but remains on the command line to which it is set.

1.2 Clearing and Shifting of Command Lines

To delete a line in the active program sequence, the cursor must be set to the respective line and softkey 5 DELETE LINE is pressed. The line numbers of the following lines are renumbered accordingly and the cursor remains in the same position, i.e. the next command line.

To clear one or more lines, the cursor is set to the beginning of the lines to be deleted and softkey 6 CUT BUFFER is pressed. Then the cursor is moved to the end of the lines to be deleted and softkey 6 CUT BUFFER is actuated again. The selected characters are then highlighted in inverse display. For moving the cursor the softkeys 11 to 15 and the spinwheel can be used. Maximally 42 lines starting from the start position of the cursor can be deleted at a time. If more lines are selected for deletion, the error message "cut buffer full" appears.

When softkey 6 CUT BUFFER is pressed the first time, CUT BUFFER is highlighted in inverse display to indicate that the delete function is active. Actuation of any other key except softkeys 11 to 15 disables the delete function again.

Pressing softkey 6 the second time resets the softkey labelling to normal display, but softkey 7 INSERT BUFFER is shown in inverse display. At the same time, the selected lines disappear from the program and the command sequence is renumbered.

However, the lines disappeared from the screen are not irrevocably lost but are temporarily stored in a buffer. Only by activating the delete function again, i.e. pressing softkey 6 CUT BUFFER again, these lines are cleared from the program for good.

Intermediate storage can also be used for shifting or copying of command lines. Any lines stored in the buffer can be inserted in one or several positions in the program sequence (except before line 0), which must be marked by cursor before.

In the example program from Section 1.1, the user wishes to copy the lines 1 to 4 into the sequence after line 9 and then delete them again:

| | | |
|--------------------|---|--|
| GOTO LINE 1 ENTER | → | Mark beginning of lines to be copied |
| CUT BUFFER | → | Activate buffer |
| GOTO LINE 5 ENTER | → | Mark end of lines to be copied* |
| CUT BUFFER | → | Fill buffer and clear lines |
| INSERT BUFFER | → | Resinsert lines |
| GOTO LINE 10 ENTER | → | Mark line from where to insert the lines |
| INSERT BUFFER | → | Insert lines |

*** Note: For copying n lines, n lines, but $n + 1$ line numbers must be marked.**

The complete program thus reads as follows:

```
0000: PROGRAM 0
0001: DISPLAY:MENU          01,00
0002: FREQUENCY:AF:I1      1000.00 Hz
0003: LEVEL:AF:I1          +25000 uV
0004: DEMODULATION:WEIGHTING RMS
0005: FILTER:TXTEST:LP     ON
0006: COUNT:RF
0007: POWER:RF
0008: DEMODULATION
0009: DISPLAY:MENU          02,00
0010: DISPLAY:MENU          01,00
0011: FREQUENCY:AF:I1      1000.00 Hz
0012: LEVEL:AF:I1          +25000 uV
0013: DEMODULATION:WEIGHTING RMS
0014:
```

The selected lines can be inserted in the program at other positions as often as required. The respective position where to add the lines is always marked by the cursor.

Lines 10 to 13 are to be deleted again:

| | | |
|--------------------|---|---------------------------------------|
| GOTO LINE 10 ENTER | → | Mark beginning of lines to be deleted |
| CUT BUFFER | → | Activate buffer |
| GOTO LINE 14 ENTER | → | Mark end of lines to be deleted |
| CUT BUFFER | → | Fill memory |

Lines 10 to 13 are thus removed again from the program and the program is reset to its original sequence.

1.3 Adding Comments in the Program

It may be useful in the course of a program run to supply additional information for the user in the second status line, for instance to switch on the radio transmitter of the mobile phone. Softkey 1 COMMENT in the AUTOEDIT menu gives access to submenu ALPHA (see Fig. 3) for input of additional comments for the program.

| | | | | |
|---|---------------------|--|--------------------|----|
| 0 | ALPHA | AUTOTEST LEARN- <STOP> to Edit | AUTOEDT | 8 |
| 1 | COMMENT: | | TEXT CURSOR | 9 |
| 2 | | | | 10 |
| 3 | | | | 11 |
| 4 | CHAR CURSOR | 0 1 2 3 4 5 6 7 8 9 A B C D E F G H I J K L M N O P Q R S T U V W X Y Z " ' ` | | 12 |
| 5 | | | | 13 |
| 6 | | = + - * / \ < > () | | 14 |
| 7 | DELETE BACKW | [] % & ! , , ; ; ! | DELETE FORW | 15 |
| | | ? \$ @ # _ \$%&'()*+,-./:;<=>?@ | | |

Fig. 3 Submenu ALPHA

For input of characters first the softkey 4 CHAR CURSOR is pressed. The characters required for the comment are selected using the VAR spinwheel and acknowledged by pressing the ENTER key. To modify the entered text (i.e. delete and insert), the softkey 9 TEXT CURSOR is pressed and the TEXT CURSOR (light characters on a dark background) set to the required position using the VAR spinwheel. Then, the letters to the left and the right of the marked location can be deleted by pressing the softkey 7 and softkey 15, respectively. Actuation of CLEAR deletes the complete comment. To insert a new text in the comment, again as described above the softkey 4 CHAR CURSOR is pressed and the required respective characters are input.

Using the STORE key, the contents of the entered comment line are stored in the program. Also several lines can be stored without leaving the ALPHA menu. Max. 34 characters per line can be entered.

Softkey MENU ↑ or softkey 8 only permit leaving the menu without storing the comment line in the program.

In the example program in Section 1.2, the user wishes to insert the comment "switch on transmitter" before the line 6:

GOTO LINE 6 ENTER → Mark the line to be preceded by a comment
 COMMENT → Access to submenu ALPHA

Select the individual characters of "SWITCH ON TRANSMITTER" using the VAR spinwheel and press the hardkey ENTER after each character to acknowledge entry.

STORE → Store the line "SWITCH ON TRANSMITTER"
 MENU ↑ → Return to the AUTOEDIT menu

The program reads as follows:

```

0000: PROGRAM 0
0001: DISPLAY:MENU          01,00
0002: FREQUENCY:AF:I1      1000.00 Hz
0003: LEVEL:AF:I1          +25000 uV
0004: DEMODULATION:WEIGHTING RMS
0005: FILTER:TXTEST:LP     ON
0006: -----switch on transmitter-----
0007: COUNT:RF
0008: POWER:RF
0009: DEMODULATION
0010: DISPLAY:MENU          02,00
0011:

```

Line 6 reads out the comment "switch on transmitter". Comments are characterized by "--" characters and are always centered. These comments can also be added for better readability of the programs. During the program run they also get displayed in the second status line.

1.4 Delays and Stops in the Active Program Run

For certain measurements, e.g. measurements at mobile phones with compandors, delays must be provided in the program sequence. Also, defined stop pauses are required in the program flow to await user reactions on comments. In this case, the pause is terminated and the program continued again by the user by pressing the hardkey START.

As the Autorun Control operates at high speed, in most cases the user is not always able to clearly follow the sequence. To avoid this, the special function also permits the user to insert defined delays between each individual command line.

The submenu SPEC-1 (see Fig. 4) is reached by pressing softkey 0 (SPEC-1) in the AUTOEDIT menu.

| 0 | SPEC-2 | SPEC-1 | AUTOTEST LEARN- <STOP> to Edit | AUTOEDT | 8 |
|---|-----------------|--|--------------------------------|-------------------|----|
| 1 | REPEAT START | | | STOP PAUSE | 9 |
| 2 | REPEAT WHILE | (NOT) COND | | PRINT CTRL | 10 |
| 3 | REPEAT STOP | | | PRT ON PRT OFF | 11 |
| 4 | IF | (NOT) COND | | PAGE FEED | 12 |
| 5 | ELSE | | LARGE MEDIUM SMALL | REPORT FORMAT | 13 |
| 6 | END IF | | 0 ms | MIN DELAY | 14 |
| 7 | NOT | DEMOD-OK RF-POWER ENTER CLEAR ERROR WARNING BCD-3 BCD-2 BCD-1 BCD-0 TOL-HIGH TOL-LOW TOL-OK | NO-STOP | COND | 15 |

Fig. 4 Submenu SPEC-1

Softkey 9 STOP PAUSE is used to define delays and stops. STOP followed by STORE is entered to set a stop in the program, which is then continued by pressing hardkey START. PAUSE and values between 1 and 10000 followed by STORE serve to effect delays in the program.

Softkey 14 MIN DELAY determines the delays between the execution of the individual commands. Delays of 0 ms (no waiting time) or from 10 ms to 10000 ms can be selected.

No entries are accepted by the CMS during these delays, i.e. the keyboard is disabled. To return to the AUTOEDIT menu, the softkey 8 AUTOEDT is pressed.

In the program example of Section 1.3, a stop is to be inserted after the comment in line 6. This is to allow the user to selectively continue the program run when the transmitter is switched on. Also, a delay of 100 m is to be defined before the DEMOD measurement in line 9. To allow the user to follow the program, a delay of 500 ms is set between the individual commands.

| | | |
|---------------------------|---|--|
| GOTO LINE 1 ENTER | → | Mark the line from where the delays apply |
| SPEC-1 | → | Access to the SPEC-1 menu |
| MIN DELAY 500 ENTER STORE | → | Insert delay of 500 ms between the individual commands |
| AUTOEDT | → | Return to the AUTOEDIT menu |
| GOTO LINE 8 ENTER | → | Mark the line to be preceded by a stop |
| SPEC-1 | → | Access to the SPEC-1 menu |
| STOP STORE | → | Insert stop pause |
| AUTOEDT | → | Return to the AUTOEDIT menu |
| GOTO LINE 11 | → | Mark the line to be preceded by a delay |
| SPEC-1 | → | Access to the SPEC-1 menu |
| PAUSE 100 ENTER STORE | → | Insert delay of 100 ms |
| AUTOEDT | → | Return to the AUTOEDIT menu |

The program example then reads as follows:

```

0000: PROGRAM 0
0001: SPECIAL:MINDELAY          500
0002: DISPLAY:MENU             01,00
0003: FREQUENCY:AF:I1         1000.00 Hz
0004: LEVEL:AF:I1             +25000 uV
0005: DEMODULATION:WEIGHTING   RMS
0006: FILTER:TXTEST:LP        ON
0007: -----switch on transmitter-----
0008: SPECIAL:STOP             0
0009: COUNT:RF
0010: POWER:RF
0011: SPECIAL:PAUSE            100
0012: DEMODULATION
0013: DISPLAY:MENU             02,00
0014:

```

Each time the CMS returns to the AUTOEDIT menu the command lines are renumbered. However, it is not necessary following each command entered in the SPEC-1 menu to return to the AUTOEDIT menu. As long as commands are entered in the SPEC-1 menu they are inserted in the program sequence in the current cursor position.

1.5 Repetitions of Program Sections

It is often required to have certain program sections repeated in the sequence if the same measurement is to be carried out with different parameters (e.g. frequency response measurements).

Softkeys 1 to 3 in the SPEC-1 menu are available for this purpose (REPEAT START, REPEAT WHILE und REPEAT STOP).

Repetitions of program sections are generally initiated via REPEAT START X or REPEAT WHILE, X being the number of repetitions ranging from 1 to 10000. REPEAT WHILE initiates a repetition of program sections until a pre-defined condition is fulfilled. To terminate the repetition, always the softkey REPEAT STOP is pressed. If no REPEAT STOP is entered, the complete program is fully executed to the end.

Repetitions can be nested to a depth of five. The following is an example for nesting to a depth of two:

```
REPEAT START 100
  further commands
    REPEAT START 10
      further commands
        REPEAT STOP
      further commands
    REPEAT STOP
  REPEAT STOP
```

The conditions to stop repetitions initiated with REPEAT WHILE can be defined in the SPEC-1 menu via the softkeys 7 NOT and 15 COND. Softkey 15 COND permits to select the condition, softkey 7 NOT can be used to negate the condition if the display of softkey 7 NOT is backlighted. For instance, REPEAT WHILE NOT WARNING means that the program section selected is repeated as long as no warning is given, while REPEAT WHILE WARNING means that the section is repeated as long as warnings are given.

The following conditions can be selected (all conditions are not negated):

| | |
|--------------------------|--|
| DEMOD-OK | Valid value of demodulated signal |
| RF-POWER | Power available |
| ENTER | ENTER key was pressed with WAIT FOR KEY |
| CLEAR | CLEAR key was pressed with WAIT FOR KEY |
| ERROR | Error messages |
| WARNING | Warnings |
| NO-STOP | always fulfilled during program execution |
| BCD-3 | Control line 3 of Control Interface CMS-B5 set to HIGH |
| BCD-2 | Control line 2 of control interface CMS-B5 set to HIGH |
| BCD-1 | Control line 1 of control interface CMS-B5 set to HIGH |
| BCD-0 | Control line 0 of control interface CMS-B5 set to HIGH |
| TOL-HIGH | Tolerance of measurement value above the set value |
| TOL-LOW | Tolerance of measurement value below the set value |
| TOL-OK | Tolerance of measurement value in the set range |
| REPEAT:WHILE:NO-STOP | opens an endless loop |
| REPEAT:WHILE:NOT NO-STOP | this loop is executed exactly once |

Note: *If the conditions BCD-0 to BCD-3 are to be used, the lines must be defined as inputs beforehand. For information on the setting of TTL-lines, please refer to that option's manual.*

With the conditions TOL-LOW, TOL-OK and TOL-HIGH, the contents of the loop are executed once in any case, with all other conditions the validity of the condition must be verified before the line REPEAT WHILE.... A loop is to be executed at least once!

In the following sequence, the program example of Section 1.4 is expanded such that by means of a pre-defined repetition the AF frequency response of the transmitter (in dB) is measured until no more RF power is applied to the CMS. To this end, first a repetition block REPEAT WHILE is inserted before line 12 with the condition RF-POWER and terminated again after line 12:

| | | |
|--------------------|---|--|
| GOTO LINE 12 ENTER | → | Mark the line where to start the repetition block |
| SPEC-1 | → | Access to SPEC-1 menu |
| COND | → | Actuate until the RF-POWER display is backlighted |
| NOT RF-POWER | → | Switch on negation to wait for RF power |
| REPEAT WHILE STORE | → | Insert repetition block |
| REPEAT STOP | → | Terminate repetition block |
| NOT | → | Switch off negation |
| REPEAT WHILE STORE | → | Insert repetition block |
| AUTOEDT | → | Return to AUTOEDIT menu |
| GOTO LINE 16 ENTER | → | Mark the line before which to terminate the repetition block |
| SPEC-1 | → | Access to SPEC-1 menu |
| REPEAT STOP STORE | → | Terminate repetition block |

The program now reads as follows:

```

0000: PROGRAM 0
0001: DELAY 500
0002: DISPLAY:MENU 01,00
0003: FREQUENCY:AF:I1 1000.00 Hz
0004: LEVEL:AF:I1 +25000 uV
0005: DEMODULATION:WEIGHTING RMS
0006: FILTER:TXTEST:LP ON
0007: -----switch on transmitter-----
0008: STOP
0009: COUNT:RF
0010: POWER:RF
0011: STOP 100
0012: SPECIAL:REPEAT WHILE NOT RF-POWER
0013: SPECIAL:REPEAT STOP
0014: SPECIAL:REPEAT WHILE RF-POWER
0015: DEMODULATION
0016: REPEAT STOP
0017: DISPLAY:MENU 02,00
0018:

```

With the repetition block inserted in program lines 12 to 14, the demodulated signal is then measured until no more RF power is applied to the CMS.

As a next step, the user wishes to measure the frequency response of the demodulated signal of 11 measurement values, starting from 500 Hz in steps of 250 Hz. The reference is 1 kHz.

| | | |
|-----------------------------|---|--|
| GOTO LINE 15 ENTER | → | Mark the line where to insert |
| START | → | Start programming |
| TX-TEST | | |
| AF1 1000 Hz STORE | → | Frequency of reference measurement |
| DEMOM STORE | → | Select DEMOD measurement |
| SHIFT REF ENTER STORE | → | Measured value set as reference |
| AF1 250 Hz STORE | → | Frequency of modulation generator set to 250 Hz |
| VAR 250 Hz STORE | → | Select 250 Hz-increment |
| DEMOM STORE | → | Select DEMOD measurement |
| STOP | → | Leave LEARN mode |
| GOTO LINE 19 ENTER | → | Mark the line to be preceded by the repetition block |
| SPEC-1 | → | Access to SPEC-1 menu |
| REPEAT START 11 ENTER STORE | → | Insert repetition block with 11 repetitions |
| AUTOEDT | → | Return to AUTOEDIT menu |
| GOTO LINE 22 ENTER | → | Mark the line where to end the repetition block |
| SPEC-1 | → | Access to SPEC-1 menu |
| REPEAT STOP | → | End repetition block |
| AUTOEDT | → | Return to AUTOEDIT menu |

The program thus reads as follows:

```

0000: PROGRAM 0
0001: DELAY 500
0002: DISPLAY:MENU 01,00
0003: FREQUENCY:AF:I1 1000.00 Hz
0004: LEVEL:AF:I1 +25000 uV
0005: DEMODULATION:WEIGHTING RMS
0006: FILTER:TXTEST:LP ON
0007: -----switch on transmitter-----
0008: STOP
0009: COUNT:RF
0010: POWER:RF
0011: PAUSE 100
0012: SPECIAL:REPEAT WHILE NOT RF-POWER
0013: SPECIAL:REPEAT STOP
0014: SPECIAL:REPEAT WHILE RF-POWER
0015: FREQUENCY:AF:I1 1000.00 Hz
0016: DEMODULATION
0017: DEMODULATION:REFERENCE
0018: FREQUENCY:AF:I1 250 Hz
0019: SPECIAL:REPEAT START 11
0020: FREQUENCY:AF:I1:VARIATION 250 Hz
0021: DEMODULATION
0022: SPECIAL:REPEAT STOP
0023: SPECIAL:REPEAT STOP
0024: DISPLAY:MENU 02,00
0025:

```

The repetition block for frequency response measurement starts from line 15. The start value of 500 Hz results from the AF generator setting plus one increment. The increment must be in the repetition block as the value is increased with each repetition.

1.6 Conditional Statements in the Program

Conditional statements with branching can be incorporated in the program using the function IF-ELSE-END IF. The softkeys 4 to 6 (IF, ELSE, END IF) in the SPEC-1 menu give access to this function.

As a rule, a conditional statement is initiated with the IF condition (with the same conditions valid as in Section 1.5) and terminated by END IF. The command ELSE can be set between these two commands, which is executed if the condition is not fulfilled.

```
IF RF-POWER
  Commands a
ELSE
  Commands b
ENDIF
```

In this example, the commands a are executed if RF power is applied and the commands b if no RF power is present. Nesting to a maximal depth of two is permissible.

Repetition blocks and conditional statements can be interleaved in the program. However, they cannot be freely nested at will:

Permissible examples:

```
IF condition 1
  REPEAT START X
    further commands
  REPEAT STOP
ELSE
  REPEAT WHILE NOT condition 2
    further commands
  REPEAT STOP
END IF
```

```
REPEAT START X
  IF condition
    further commands
  ELSE
    further commands
  END IF
REPEAT STOP
```

Illegal examples are:

```
REPEAT WHILE condition 1
  IF condition 2
    further commands
  REPEAT STOP
ELSE
  further commands
END IF
```

Repetition blocks and conditional statements must also be completed.

1.6.1 Conditional Execution of Program Sections

| | | | | | | |
|---|---------------|---------------------------------|--------------------------------|----------|-----------------|----|
| 0 | SPEC-1 | SPEC-2 | AUTOTEST LEARN- <STOP> to Edit | AUTOEDT | 8 | |
| 1 | LOOP BREAK | (LEVEL) | PROG-CARD | PROG-INT | CALL | 9 |
| 2 | | | (PROG-NUMBER) | | RETURN | 10 |
| 3 | | | | | | 11 |
| 4 | | | | | WAIT FOR KEY | 12 |
| 5 | | | | | | 13 |
| 6 | CASE | OF LOOPINDEX | | | | 14 |
| 7 | CASE COND | EQ LE GE (VALUE) OTHER END | | | | 15 |

Fig. 5 Submenu SPEC-2

The menu SPEC-2 offers extended possibilities of program generation:

Conditional execution of program sections (depending on the loop counter):

In order to be able to perform different settings when a loop is executed repeatedly, softkey 6 and softkey 7 permit to use a case differentiation of the following type:

REPEAT:START or REPEAT:WHILE

Beginning of loop

The commands are always executed in this case.

**CASE:OF:LOOP
CASE:COND EQ 3**

Beginning of case differentiation

The commands are only executed in loop 3.

CASE:COND EQ 7

The commands are only executed in loop 7.

CASE:COND OTHER

The commands are executed in all runs except for loop 3 and 7.

CASE:COND END

End of case differentiation

The commands are always executed.

REPEAT:STOP

End of loop

After starting a case differentiation, an appropriate case specification is searched for in the following commands until the end of the case differentiation (CASE:COND:END or end of program), i.e. the command CASE:OF:LOOP (softkey 6) must always be followed by a CASE:COND command (softkey 7) in the next line.

If the condition of a CASE:COND line is fulfilled, the following commands are executed.

The subsequent CASE:COND command (independent of a condition) or the program end terminate the command execution.

Possible case specifications:

- EQ number loop index = number
- LE number loop index \leq number
- GE number loop index \geq number

- OTHER any loop index unequal to the ones used with EQ, LE or GE!
- END end of case differentiation

Waiting for user entry

If a program run is to depend on decisions of the user, softkey 12 (WAIT FOR KEY) can be used to determine that a user entry is waited for.

During the program run, the user is requested at this place to make an entry, which sets the conditions ENTER and CLEAR as follows:

| User entry | Condition | |
|---------------|-----------|-------|
| | ENTER | CLEAR |
| ENTER | true | false |
| CLEAR | false | true |
| Any other key | false | true |

The conditions ENTER and CLEAR can be read out in conditional loops and in IF conditions.

Aborting a loop (softkey 1 : LOOP BREAK)

The LOOP BREAK command allows loop-execution (endless loops or a loop with a high repetition number) to be terminated prematurely when the desired result is obtained.

Normally, the current loop is concerned; however, several nested loops can also be terminated by indicating the appropriate number.

Example:

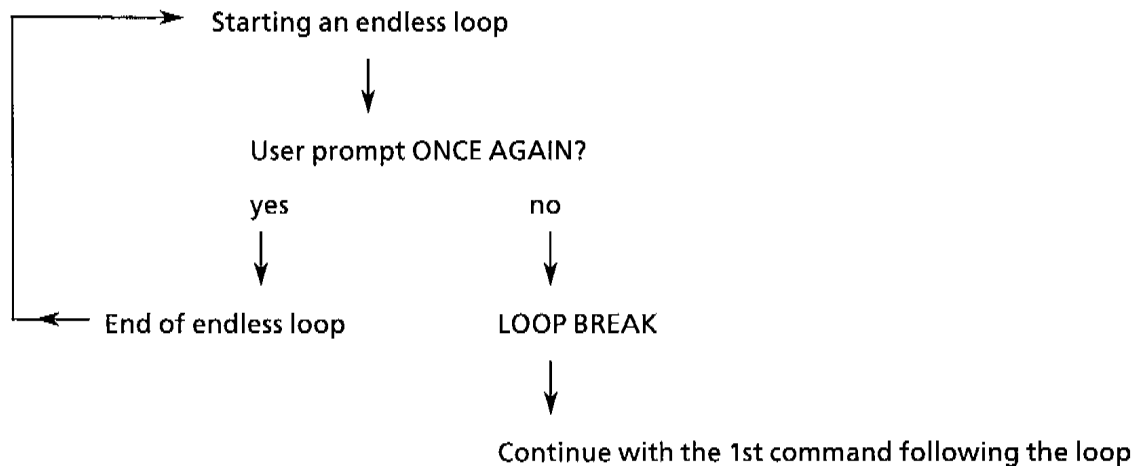

Calling up programs by other programs

Softkey 9 (CALL) can be used to insert a program call (internal or from memory card) into another program.

When syntax testing, a check is made to see whether the program to be called is available; otherwise, a warning is generated. The program generation itself, however, can be terminated by changing to the AUTOTEST menu.

During the program run, the execution is continued with the first command of the program indicated. A return to the calling program is possible with a RETURN command or at the end of the called program.

Softkey 10 (RETURN) can be used to return to the calling program prematurely. During the program run, the execution is continued with the next command of the calling program after the call. If there is no calling program, the program execution is terminated as with a program end.

1.7 Printer Control during the Program Run

A printer connected to the CMS to give out test reports can be directly controlled from the program sequence. Softkeys 10 to 13 (PRINT CTRL, PRINT ON, PRINT OFF, PAGE FEED, REPORT FORMAT) in the SPEC-1 menu are used for this purpose.

With softkey 10 PRINT CTRL, control characters can be sent to the printer which are normally not included in the printouts but effect switchover of printer functions, e.g. switching on or off of the underline function.

These control characters can be entered only in the HEX code. Maximally 10 characters per command line are permissible.

The control characters are entered via the keypad (0 to 9 and A to F) and each entry is completed by pressing hardkey STORE.

The printer can be switched on or off during the program run using the softkey 11 (PRINT ON, PRINT OFF). Again, these commands are acknowledged by pressing hardkey STORE.

Softkey 12 is used to effect form feed.

The softkey function 13 REPORT FORMAT can be used to select the format of the printout (SMALL, MEDIUM or LARGE) during the program run (see Section 1.7.2).

Note: *Softkey 5 REPORT TARGET has highest priority in the AUTORUN menu. If the target for the report is set to OFF, all the printer controls in the program are disabled.*

Example: The printer is to be initialized at the beginning of a sequential program (CMS in AUTOEDIT menu (command sequence for this printer HEX: 1B 40), the protocol format be set to LARGE and the printer then be switched on. Following further commands, i.e. measurements, the report is to be generated:

| | | |
|--------------------------|---|---|
| SPEC-1 | → | Access to the SPEC-1 menu |
| PRINT CTRL 1 B 4 0 STORE | → | HEX code for initialization |
| PAUSE 1000 STORE | → | Insert delay before new commands can be sent to the printer |
| REPORT FORMAT | → | Press softkey until LARGE display is backlighted |
| STORE | → | Store function |
| PRINT ON STORE | → | Switch on printer |
| AUTOEDT | → | Return to AUTOEDIT menu |

The following command lines are displayed:

```
0006  previous command
0007  PRINT CTRL 1B 40
0008  PAUSE 1000
0009  REPORT FORMAT LARGE
0010  PRINT ON
0011  further commands
```

If the function PRINTER or MEMCARD is selected in the AUTORUN menu using softkey 5 REPORT TARGET, a report header information is generated at each program start and the subsequent program lines are printed out until PRINT OFF is set.

1.7.1 Printing of Reports

All the parameters measured during the program run can be given out to a printer in form of reports or be stored on a memory card. Test reports are printed out in the following form:

```
REPORT: 26      PROGRAM: 03      20-APR-89 09:24      USER: XXXXXX
DEVICE under TEST IDENTIFICATION:.....
```

| NO | COMMAND | PARAMETER | RESULT | TOL |
|------|-----------------|------------------|----------|-------|
| 0001 | ----- | TRANSMITTER TEST | ----- | |
| 0002 | LEVEL:RF | 0.1 mV | | |
| 0003 | DEMODULATION | | 2.75 kHz | OK |
| 0004 | DEMODULATION | | 4.45 | FAULT |
| 0005 | SINAD | 20 dB | 20.1 dB | |
| --- | RF LEVEL | | 0.5 uV | |
| 0006 | LEVEL:RF | : :1MV | | |
| 9999 | TOTAL TOLERANCE | | | FAULT |

Explanations:

| | |
|------------|--|
| NO: | Line number of active program |
| COMMAND: | IEC bus format of command |
| PARAMETER: | Preset parameter settings |
| RESULT: | Measurement results as specified in the display. In the case of two measurement results (SINAD search routine), the second value is indicated in a subsequent line (marked by →). |
| TOL: | Tolerance evaluations are listed in the report only for those commands which are immediately followed by +TOL and/or -TOL. OK means no violation of the tolerance range, FAULT means that the tolerance limit is exceeded. |
| :: | In the case of setting values, which are stated only in the course of the active program sequence, the entered value is documented after :: . |

Report header: (see Section 2.1.1).

If the program data in the report include tolerance evaluations, the individual tolerance evaluations are automatically summed up at the end of the report, i.e. the section TOTAL TOLERANCE lists if no (OK) or at least one tolerance violation (FAULT) has occurred during the program run.

1.7.2 Report Formats

The format of the report can be defined by the user before starting the program sequence or from the active program using REPORT FORMAT LARGE, REPORT FORMAT MEDIUM or REPORT FORMAT SMALL. If the program sequence is already started, the user can no longer manually modify the format from the active program. It is neither possible to modify the format of already executed reports.

Three report formats are available:

REPORT FORMAT LARGE: Complete logout of program data, i.e. all commands, comments and measurements are documented.

REPORT FORMAT MEDIUM: Commands pertaining to the autorun control (e.g. changing of menus) and all settings are suppressed. However, setting values which are stated only in the course of the program run are included in the report.

REPORT FORMAT SMALL: Only measurement data are reported.

2 Execution of Programs

A program generated in the AUTOEDIT menu can be started from the AUTORUN menu. To access the AUTORUN menu, the softkey 3 AUTORUN is pressed in the AUTOEDIT menu.

| | | | | | | | | |
|---|------------------|---------------------------------|-----------|--------|-------|-----------|------------------|----|
| 0 | AUTOEDT | AUTORUN CMS - Local | | | | | AUTOTST | 8 |
| 1 | SELECT | PROG-INT | PROG-CARD | REPORT | OTHER | FREE INT | 22544 | 9 |
| | | 0 0 | 0 0 | 0 0 | 0 4 | FREE CARD | 0 | |
| 2 | | | | | | | | 10 |
| 3 | REPORT HEADER | DATE/TIME: dd-mm-yy HH:MM USER: | | | | | DATE TIME | 11 |
| | | DUT IDENT: | | | | | | |
| 4 | REPORT FORMAT | SMALL MEDIUM LARGE | | | | | | 12 |
| 5 | REPORT TARGET | OFF PRINTER MEMCARD | | | | | PRINTER INIT | 13 |
| 6 | STOP COND | NO-STOP TOL-ERR WARNING ERROR | | | | | FORM FEED | 14 |
| 7 | MIN DELAY | 0 ms | | | | | SPOOLER CLEAR | 15 |

Fig. 6 Submenu AUTORUN

This menu permits to set or modify the parameters required for the program execution. The program execution is started via hardkey START. This can be done in any menu. The currently selected program is started. Moreover, internal programs can be started from any menu by the combination of <START>, program number, <ENTER>.

Once the program sequence is started, the CMS is in AUTOTEST RUN mode. The first status line reads out the message AUTOTEST RUN - HOLD by <STOP>.

In this mode, the CMS executes all the commands stored in the active program in the sequence as entered.

2.1 Parameters for Program Execution

It is possible before starting the program run to set some parameters which are not yet determined in the actual program setup (cf. Sections 2.1.1 to 2.1.8). Other functions such as COPY additionally require the desired program/report number to be entered directly above the number field.

Information on the selected programs and reports is read out in the two lines between softkeys 1 and 9.

In the CMS the following data types in short-form are available in these two lines:

- PROG-INT: CMS-internal programs
- PROG-CARD: programs on memory card
- REPORT: reports on memory card
- OTHER: stored instrument states (=PANEL) and other data types on memory card

The left-hand number below each data type indicates the memory occupied by the data type (in characters), the right-hand number specifies the number of the currently selected program/report.

To the right of the abbreviations

FREE INT: internal program memory,

FREE CARD: memory card,

the size of the available (free) memory is indicated.

2.1.1 Report Header

Each report contains a report header at the beginning, which specifies the current date, the user and a DUT identification. On actuation of softkey 3 REPORT HEADER, the menu REPORT (similar to the ALPHA menu) is automatically called up and the user can enter the respective data as described in Section 1.3. To leave the REPORT menu again, the hardkey MENU ↑ is pressed.

In addition, also not the following:

A text can be entered in the fields USER or DUT IDENT or an already existing text be modified by pressing the softkey 9 TEXT CURSOR, if required several times. The field DATE/TIME is selected by pressing softkey 1 DATE/TIME.

In the field DATE/TIME, each numeric value of the date section can be directly set (i.e. incremented or decremented) using the VAR spinwheel. The individual numeric values are selected by pressing the softkey 1 DATE/TIME several times. The softkeys 7, 15 and ENTER have no functions in this case, CLEAR initializes the field.

2.1.2 Report Formats

Softkey 4 REPORT FORMAT is used to select one of the report formats, LARGE, MEDIUM or SMALL (cf. Section 1.7.2). If a format has been selected during program generation, the pre-set format is modified in the program irrespective of the setting of softkey 4 from the position where such a command has been inserted in the active program.

2.1.3 Target Address of Report

Softkey 5 REPORT TARGET selects the target address of the test report, i.e. PRINTER or memory card MEMCARD, or no report (OFF).

In the OFF setting, any printer control commands entered in the program are disabled (cf. Section 1.7).

2.1.4 STOP Conditions

Softkey 6 STOP COND permits to select one of the following conditions: NO STOP, stop in the case of violations of the tolerance range (TOL ERR), stop with warnings (WARNING) or stop of the program with error messages (ERROR).

Irrespective of the setting of softkey 6, any stops entered in the program as commands are executed (cf. Section 1.4).

2.1.5 Delays in the Program

Softkey 7 MIN DELAY has the same function as softkey 14 in the SPEC-1 menu (cf. section 1.4).

The delay set is valid until it is overwritten by a MIN DELAY command stored in the program.

2.1.6 Initialization of the Printer

Softkey 13 PRINTER INIT is used to enter the command sequence for initialization of the connected printer. The characters are entered in the HEX code via the keypad (0 to 9 and A to F). The initialization itself is started using hardkey ENTER.

2.1.7 Form Feed of the Printer

Softkey 14 FORM FEED is used to effect a form feed of the printer, which sets the print head to the next page to the beginning of the first line.

This function is above all useful to coordinate the line counter of the CMS with the connected printer.

2.1.8 Clearing of the Printer Buffer (SPOOLER CLEAR)

All the characters for printout are stored in a buffer (SPOOLER). During printing, these characters are read from the buffer in the sequence as stored. This offers the advantage that no delays are required for printing and that printing is carried out in background mode, i.e. the CMS is immediately ready for user operation again.

To abort printing, the buffer must be cleared using softkey 15 SPOOLER CLEAR.

2.2 Program Suspensions

The active program can be stopped by pressing hardkey STOP, as a result of programmed stops or by one of the stop conditions STOP COND. The first status line displays the message AUTO HOLD - <START> <STOP> <RETURN>.

The display then shows the menu which was valid before the active program was started, or the menu called up by programming. The CMS is ready for entries of settings, which, however, are not transferred to the program, but still define the setting of the CMS hardware unless modified during further program execution.

To leave the HOLD mode and restart the program, the hardkey START is pressed. The program is continued exactly where it was interrupted.

When hardkey STOP is pressed again, the CMS leaves the AUTOTEST mode and is switched to manual operation in the currently displayed menu.

When hardkey RETURN is pressed in the HOLD mode, the CMS accesses the AUTORUN menu and the report number is incremented by one. This means that the report number must not always be entered before program start. The program can again be executed using hardkey START.

If the user accesses the submenu AUTOEDIT from the AUTORUN menu via the AUTOTEST menu, the first 14 lines of the program are not displayed as is normally the case but the cursor marks the first command in the program sequence that was not yet executed. If the program has been completely executed, the cursor marks the first free line of the program. However, in the case of error it is easier for the user to verify the cause of error if the program is not completely executed.

3 Management of Programs and Test Reports

All the functions required for the management of program and test reports (loading, saving, printing and display) are accessible from the AUTOTEST menu (see Fig. 1). Maximally 100 programs can be stored in the CMS, additional programs must be loaded via memory cards where they are stored.

3.1 Dealing with Programs and Reports from Memory Card

Softkey 1 SELECT in the AUTOTEST menu allows to select a program or a report to be dealt with. The program or report is selected by entering the respective number. Loading is effected by pressing softkey 5 COPY <-MEMCARD.

It is possible only to load programs from the memory card into the CMS, typing or printing of files is possible without loading them into CMS, however.

3.2 Linking of Programs

Several individual programs can be linked to one program. First one program is loaded and the memory card program to be appended selected using softkey 1. Both programs are linked together by means of the softkey function 7 (APPND <-MEMCARD).

3.3 Storing of Programs and Reports

Programs generated in the CMS can be stored on the memory card using softkey 6 COPY -> MEMCARD. For this purpose, first both program numbers must be entered via softkey 1. If a program with the same number already exists on the memory card, the message "DELETE EXISTING PROGRAM?" is given out. Pressing the ENTER key overwrites the already existing program, CLEAR is used for aborting. The same applies if, after a START command is issued, a particular report number is already in use.

3.4 Display of Directory

The programs available in the CMS as well as the programs and test reports stored on the memory card can be displayed via softkey 2 DIR. Via softkey 1 SELECT, the user needs to select if programs in the CMS or on memory card are to be displayed. The same applies for data types REPORT and OTHER, however these are only available on memory card.

The display reads out the number and the first line of the programs. Therefore, when generating a program a comment should always be inserted in the first program line to identify the program.

With reports, the report number and the DUT identification should always be specified (cf. Section 2.1.1).

If more programs or test reports are available than can be displayed, the softkeys 14 PAGE UP and 15 PAGE DOWN are provided to call up the other programs or reports.

3.5 Display and Printing of Programs or Reports

If a program or report is selected by softkey 1, softkey 4 TYPE can be pressed to have its contents displayed. Paging through the contents is possible by means of softkeys 14 PAGE UP and 15 PAGE DOWN.

Using softkey 3 PRINT, the selected program or report can be printed out on a printer connected to the CMS.

3.6 Clearing of Programs and Reports

Programs and reports can be cleared from the memory card or CMS using softkey 10 DELETE. First the program or report to be deleted is selected via softkey 1. Before the program or report is deleted, the user is prompted by "ARE YOU SURE?". ENTER acknowledges deletion, CLEAR is pressed for aborting.

The entire contents saved on the memory card or all the programs in the CMS can be cleared by means of softkey 11 FORMAT. Again, softkey 1 is used for selecting. The user is prompted again by "ARE YOU SURE?", which is acknowledged by ENTER or aborted by CLEAR.

3.7 Password protection of programs

On entering the AUTOTEST menu, softkey 12 (PASSWD PROTECT) is either set active (inverted) or toggled off (white background), depending on the state of the toggle SELECT (softkey 1). Since programs may be protected only, softkey 12 will always show protection to be inactive if softkey 1 does not select a program. Deletion of existing reports only happens after an appropriate runtime prompt issued through stateline 2. Protection of programs works in the following pattern:

User action

CMS response in stateline 2

- | | |
|--------------------------------------|---------------------------------------|
| a) Select PROG-INT or PROG-CARD | - none - |
| b) Engage softkey 12 | "Please enter password" |
| c) Value between 1 and 60000 & ENTER | "To verify, please re-enter password" |
| d) Retype chosen value & ENTER | "Programs now password-protected" |
| e) - Softkey 12 is in active state - | |

Removal of password protection works in similar fashion:

- | | |
|---------------------------------------|----------------------------|
| a) Select PROG-INT or PROG-CARD | - none - |
| b) Engage softkey 12 | "Please enter password" |
| c) Value between 1 and 60000 & ENTER | "Programs now unprotected" |
| d) - Softkey 12 is toggled inactive - | |

An important difference between internal and memory-card protection is that the whole of the memory-card program space is protected through softkey 12, i.e. no transfer of programs to memory-card is possible while protection is active, even if the chosen program number is not in use. With internal protection, new programs may be added despite softkey PASSWD PROTECT being active; however, these new programs will automatically be password-protected the moment they are completely written to CMS internal memory. Password-protection, if set active, affects the commands assigned to softkeys 5, 6, 7, 10 and 11, which is every action that modifies internal programs or writes to memory-card program space respectively.



ROHDE & SCHWARZ

Test and
Measurement Division

VOR/ILS-GENERATOR (only CMS 57)

Printed in the Federal
Republic of Germany

CERTIFICATE OF TRACEABILITY

The

**ROHDE & SCHWARZ Service Monitor
with integrated
VOR/ILS Generator
CMS57**

Identity No. 0840.0009.57

has been manufactured and tested at ROHDE & SCHWARZ, MESSGERÄTEBAU GMBH in Memmingen.

The measuring equipment used for pre and final test is calibrated according to ROHDE & SCHWARZ standards.

The accuracy of the measuring equipment is derived from officially recognized standards at PTB (Physikalisch Technische Bundesanstalt) or equivalent organizations like DKD (German Calibration Service) or NIST (National Institute of Standards and Technology).

The calibration as well as the procedure for monitoring the accuracy and the traceability of the standards applied correspond to Mil-Std. 45662 and AQAP 6.

The measured values were found to lie within the limits of the equipment specifications.

**ROHDE & SCHWARZ
MESSGERÄTEBAU GMBH**

i.v. Bechteler
Bechteler

i.A. Baldermann
Baldermann

Contents

| | | Page |
|------------|--|------|
| 1 | Information on Air Navigation | 5 |
| 1.1 | Determination of Position Using VOR | 5 |
| 1.2 | Landing Approach with ILS | 5 |
| 1.2.1 | Localizer | 6 |
| 1.2.2 | Glide Slope | 6 |
| 1.3 | Marker Beacon | 7 |
| | | |
| 2 | Application of the Signal Generators | 7 |
| | | |
| 3 | Function Principle of the Signal Generators | 8 |
| 3.1 | Function Principle of the VOR Signal Generator | 8 |
| 3.2 | Function Principle of the ILS Signal Generator | 9 |
| 3.3 | Function Principle of the Marker Beacon Signal Generator | 9 |
| | | |
| 4 | Operation of the VOR/ILS Signal Generator | 10 |
| 4.1 | Menu Structure | 10 |
| 4.2 | General Operation Features of the Operating Modes VOR, ILS-LOC, ILS-GS and MB | 12 |
| 4.2.1 | Switchover AF Output or Modulation to RF Carrier | 12 |
| 4.2.2 | RF Frequencies | 12 |
| 4.2.3 | VAR Function | 12 |
| 4.2.4 | Presettings | 12 |
| 4.3 | VOR Menu | 13 |
| 4.4 | ILS Menu | 15 |
| 4.5 | Marker Beacon Menu (MB) | 19 |
| | | |
| 5 | IEC-Bus Commands for VOR/ILS Signal Generator | 22 |

| | | |
|------------|---|----|
| 6 | Performance Test | 26 |
| 6.1 | Required Measuring Instruments and Accessories | 26 |
| 6.2 | Testing the Rated Specifications | 27 |
| 6.2.1 | General Information | 27 |
| 6.2.2 | AM Modulation and AM Distortion | 27 |
| 6.2.3 | VOR Phase | 27 |
| 6.2.4 | ILS Phase | 28 |
| 6.2.5 | DDM Measurement at the RF Output with ILS Signals | 28 |
| 6.2.6 | DDM Measurement at the AF Output with ILS Signals | 29 |
| 6.3 | Performance Test Report | 30 |

1 Information on Air Navigation

1.1 Determination of Position Using VOR

The VOR (=VHF Omnidirectional Radio Range) is an omnidirectional beacon in the VHF range enabling the pilot of an aircraft to determine its position in the air. This is achieved by VOR ground stations sited at defined co-ordinates, emitting the same RF carrier via two different antennas. One of the antennas radiates in all directions, the second one emits a rotating beam. This antenna rotates at 30 revolutions per second, thus leading to an amplitude modulation of 30 Hz with the transceiver aboard the aircraft. The same RF carrier is transmitted via the omnidirectional antenna, but it is amplitude-modulated with the frequency 9960 Hz. This subcarrier is again frequency-modulated with a 30-Hz reference signal. Since the phasing of the rotating amplitude-modulated signal depends on the direction it can be used for determining the position of the aircraft. The frequency-modulated 30-Hz signal is referred to as reference phase. The reference signal and the rotating beam are synchronized such that a receiving instrument, which is located in magnetic north direction to the transmitter, receives both with a phase offset of 0° (cf. fig. 1). If, e.g., the position of the aircraft is 90° to the VOR transmitter base, the amplitude-modulated 30-Hz signal is received with a phase offset of 90° to the reference signal.

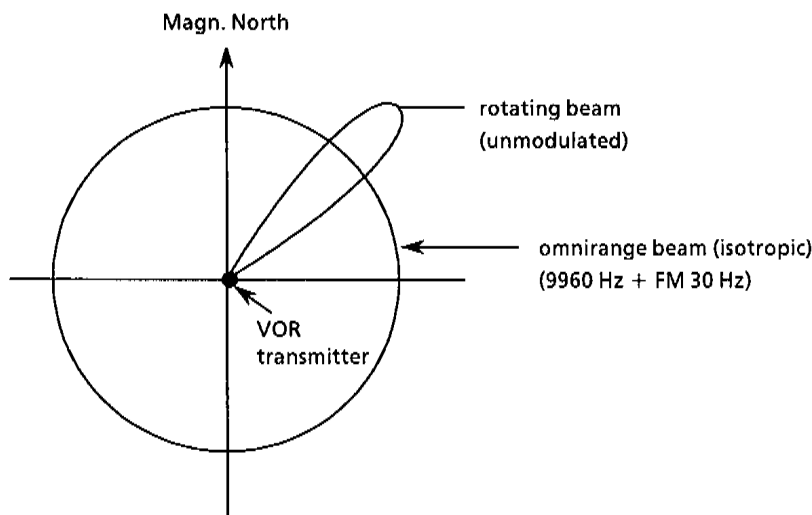

Fig. 1 VOR function principle

1.2 Landing Approach with ILS

The ILS (=Instrument Landing System) is a radio landing system, which allows for an approaching aircraft to be lead in the right angle until touchdown. The ILS consists of two function units. The localizer determines the vertical approach angle whereas the glide slope determines the horizontal angle to the touchdown point. The ILS ground transmitter emits four lobe-shaped beams in the direction of the approach line. The two lobes of the localizer are arranged in parallel, i.e. one on the right and one on the left side, those of the glide slope in vertical order, i.e. as an upper and a lower lobe. The antennas each emit amplitude-modulated RF carriers. The carrier frequencies are different for the glide slope and the localizer (cf. fig. 2).

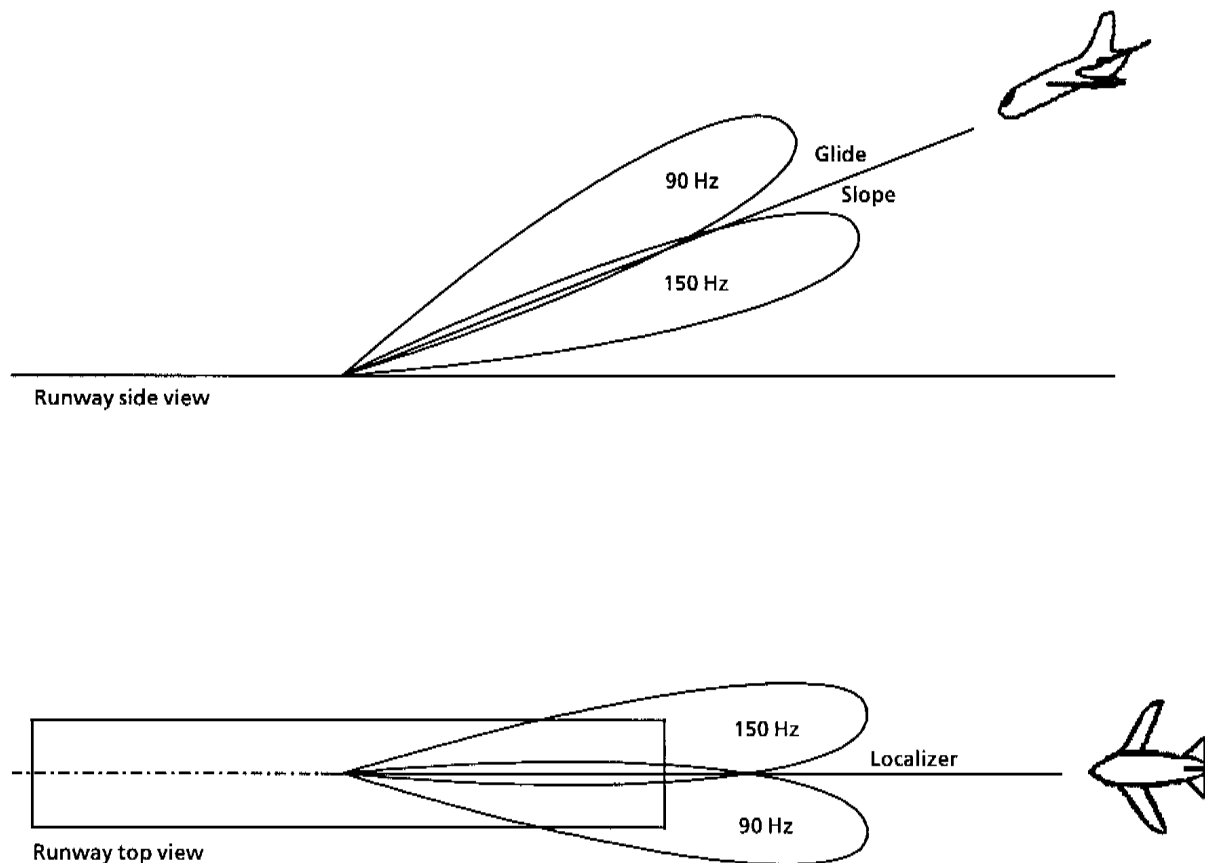

Fig. 2 ILS function principle

1.2.1 Localizer

Looking into approach direction, the left antenna of the localizer emits an RF carrier modulated with 90 Hz, the right one an RF carrier modulated with 150 Hz with a modulation depth of 20 % each. Both radiation fields slightly overlap. The points where both fields can be received with the same strength form a level which corresponds to the correct vertical approach angle. Since the 90-Hz tone and the 150-Hz tone use the same carrier, a different field strength on the receiver causes a different modulation of both tones. The ILS receiver aboard the plane measures and displays the difference of both modulation depths in DDM (= Difference in Depth of Modulation). DDM = 0 thus means that the aircraft is positioned in the right approach angle to the runway.

1.2.2 Glide Slope

The function principle of the glide slope corresponds to that of the localizer. However, the two radiation patterns are arranged in vertical order such that the points of the same field strength form a level which corresponds to the correct glide angle. The lower antenna of the glide slope emits an RF carrier modulated with 150 Hz, the upper one emits an RF carrier modulated with 90 Hz, the modulation depth being 40 % each.

1.3 Marker Beacon

The marker beacon is an RF transmitter within the 75-MHz band located in the approach line to the runway. Its directional antennas radiate the RF power vertically upward. Thus, the receiver aboard the aircraft receives and displays a signal only when flying over the marker beacon. Up to three markers are situated one after the other in the approach lane. The RF carrier of each marker beacon is amplitude-modulated with a different AF frequency.

| | | | |
|--------|-------------|---|---------|
| Outer | Marker (OM) | = | 400 Hz |
| Middle | Marker (MM) | = | 1300 Hz |
| Inner | Marker (IM) | = | 3000 Hz |

The receiver is enabled to indicate, which marker the aircraft is just passing by means of selection of the individual tones.

2 Application of the Signal Generators

The CMS signal generators for VOR, ILS glide slope, ILS localizer and marker beacon allow for generating the same signals which are transmitted by a VOR/ILS ground station. They are provided at the RF IN/OUT connector and can thus be directly fed to the antenna connector of the VOR/ILS receiver. Optionally, an AF signal can be generated at the MOD GEN output in order to modulate an external RF synthesizer. In addition to the signal generator the CMS provides the measuring functions SCOPE and AF voltmeter.

3 Function Principle of the Signal Generators

3.1 Function Principle of the VOR Signal Generator

The VOR signal generator consists of three AF generators. The first one generates a 30-Hz signal which is varied in phase on the one hand by means of a phase shifter and which is on the other hand frequency-modulated with its fixed phase to the signal of the second generator (9960 Hz), serving as subcarrier. The third generator provides a so-called auxiliary tone of 1020 Hz. All frequencies of the AF generators are default values, which can be varied for test purposes. The amplitudes of the subcarrier, the auxiliary tone and the 30-Hz signal with the variable phase can now be individually attenuated. The three signals are then added up via an adder and either applied to the AF connector MOD GEN via a variable amplifier or modulated to a variable RF carrier by means of an amplitude modulator. The RF signal which can be varied in level over a wide range is output at the RF IN/OUT connector.

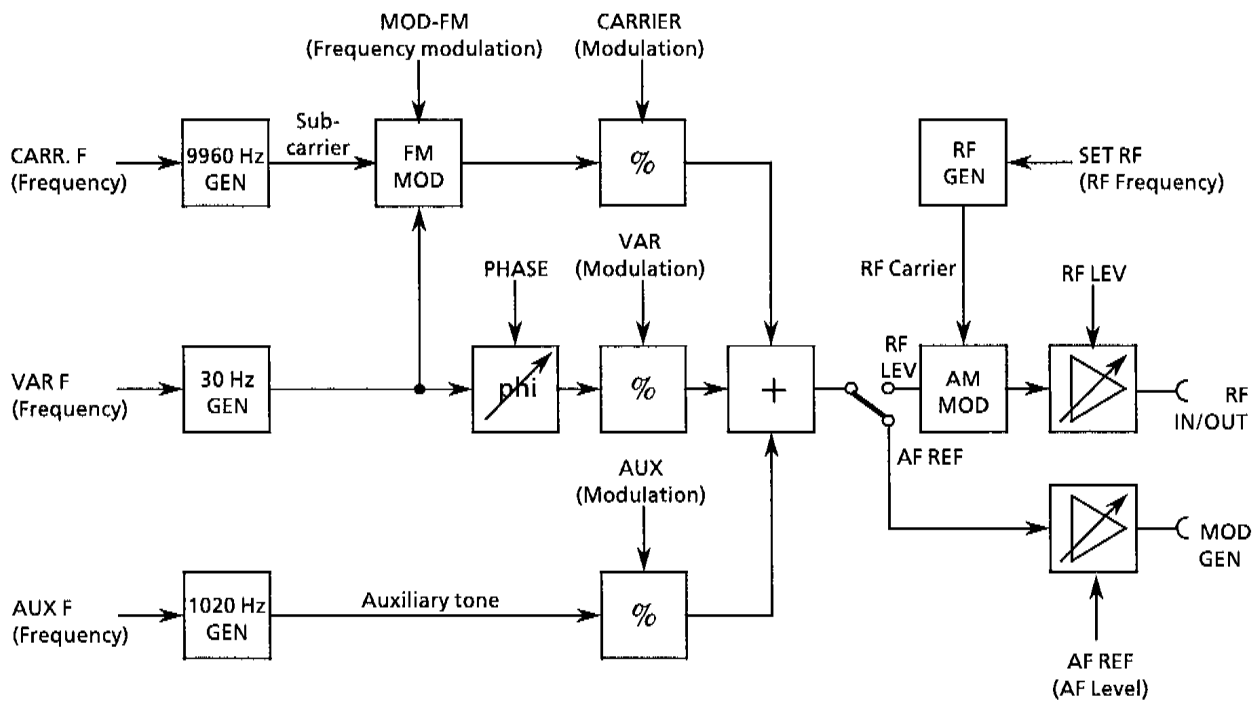

Fig. 3 Block Diagram "VOR Signal Generator"

3.2 Function Principle of the ILS Signal Generator

The ILS signal generator consists of three AF generators. The first two generators supply the 90-Hz signal and the 150-Hz signal. The frequency ratio is 3/5 with the generators being phase-locked. The user can set a phase offset of 0° to 100° relating to the 150-Hz signal. The third generator generates an auxiliary tone of 1020 Hz. All frequencies of the AF generators are default values which can be varied for test purposes. The amplitudes of the 90-Hz tone and the 150-Hz tone as well as that of the auxiliary tone can now be individually attenuated. The three signals are then added and either applied to the AF connector MOD GEN via a variable amplifier or modulated to a variable RF carrier by means of an amplitude modulator. The RF signal which can be varied in level over a wide range is output at the RF IN/OUT connector (cf. fig. 4). This generator is used for glide slope and localizer operation.

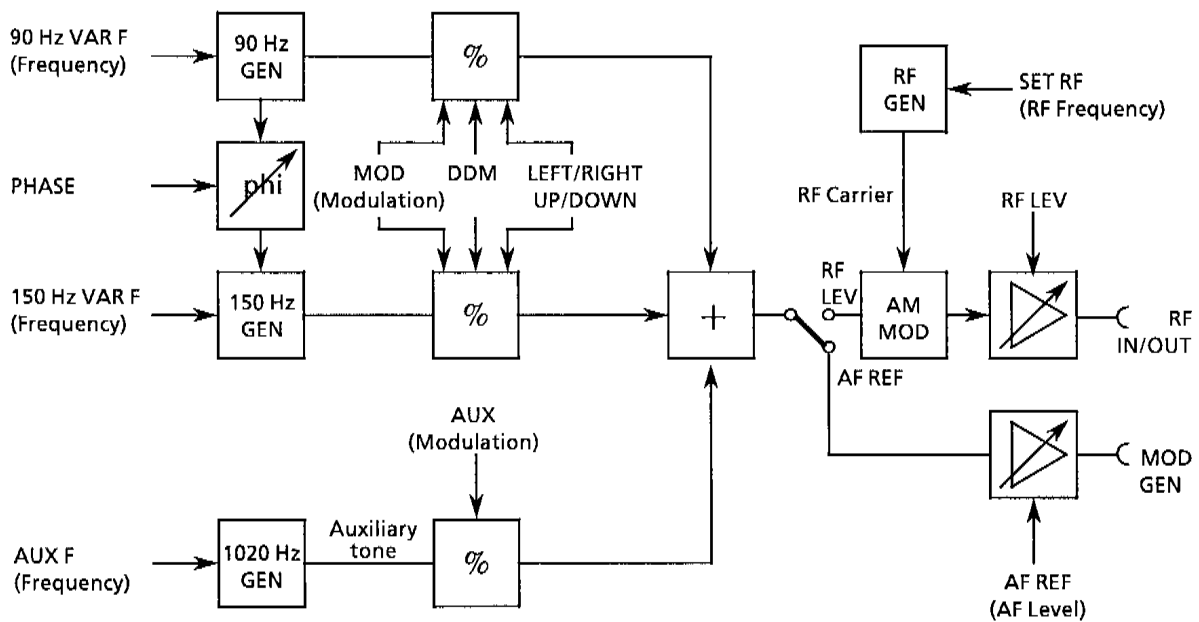

Fig. 4 Block Diagram "ILS Signal Generator"

3.3 Function Principle of the Marker Beacon Signal Generator

The marker beacon signal generator consists of two AF generators. The first one generates a sine wave signal with one of the three specified frequencies (300 Hz, 1300 Hz, 3000 Hz). The second generator provides an auxiliary tone of 1020 Hz with the frequency, however, being variable over a wide range. The amplitudes of both tones can be attenuated individually. They are then added by means of an adder and output to the AF connector MOD GEN via a variable amplifier or modulated to an RF carrier by means of the amplitude modulator. The RF signal which can be varied in level over a wide range is output at the RF IN/OUT connector.

4 Operation of the VOR/ILS Signal Generator

4.1 Menu Structure

Four menus are reserved for the VOR/ILS generator:

- VOR
- ILS-GS (ILS glide slope)
- ILS-LOC (ILS localizer)
- MB (marker beacon)

| | | | | | |
|---|---------|---|-------------------------|---------|----|
| 0 | RX-TEST | SELECT | CMS - Local HARDCOPY | TX-TEST | 8 |
| 1 | AUTOTST | RADIOCOMMUNICATION SERVICE MONITOR | | TONES | 9 |
| 2 | DX-TEST | | | CR | 10 |
| 3 | SPECT | | | VOR | 11 |
| 4 | SSB | | | ILS/MB | 12 |
| 5 | | | | ERMES | 13 |
| 6 | NATION | | | GB | 14 |
| 7 | CONFIG | | | | |
| | | | | SELFCHK | 15 |

Fig. 5 SELECT menu

The SELECT menu allows for selecting the VOR menu by pressing softkey 11 or for selection of the ILS-LOC menu by pressing softkey 12. The ILS-GS menu can be entered by pressing softkey 0 in the ILS-LOC menu, the MB menu is reached by pressing softkey 8. The softkey MENU UP is used for returning to the SELECT menu from each of the four above-mentioned menus.

The softkey AF MOE (9) can be actuated in the VOR, ILS-GS and ILS-LOC menus for calling a submenu enabling the measuring functions Scope, AF voltmeter and DC voltmeter (only with built-in option CMS-B20). These measuring functions are implemented as a standard in the marker beacon menu MB. Operation of the oscilloscope corresponds to the operating modes transmitter test or receiver test. The submenus of these functions, however, cannot be entered in this application.

The oscilloscope can be set to FREEZE/ CONTINUOUS modes by activating softkey 11 and pressing the CLEAR/ ENTER key.

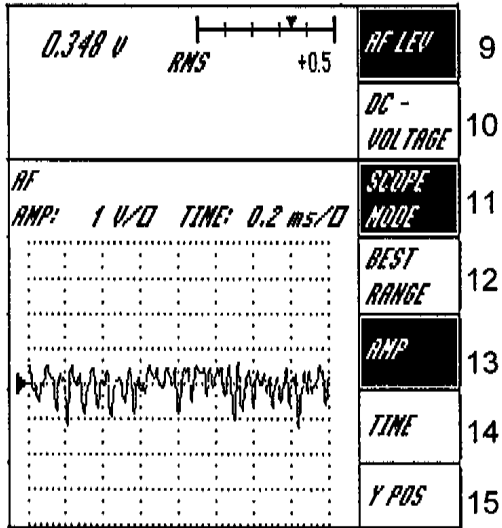

Fig. 6 Submenu AF MODE

4.2 General Operation Features of the Operating Modes VOR, ILS-LOC, ILS-GS and MB

4.2.1 Switchover AF Output or Modulation to RF Carrier

The softkey RF LEV/AF REF (2) is assigned two functions. First, it is used for selecting, whether the AF signals are output at the MOD GEN connector or amplitude-modulated to an RF carrier and output at the RF IN/OUT connector. The second function is the setting of the AF or RF output level. If the RF LEV field is inverted (bright characters on a dark background), the measuring signal is output in modulated form and the value displayed is the RF level. If the active cursor is located at this position, a new RF level can now be entered with the units dBm or μ V. If the AF REF field is inverted, the AF signal is directly output. The displayed value then means the reference output level, the proportional modulation values of the individual signals refer to. This level can either be output in V, mV or μ V.

4.2.2 RF Frequencies

The SET RF function is used for setting the frequency of the RF carrier. Each of the 4 menus contains an individual table listing the standard frequencies for VOR, ILS and MB (cf. table 1, page 19). The values are called by rotating the VAR spinwheel. The two frequencies for ILS-LOC and ILS-GS are always paired, i.e., in case of a switchover from one menu to the other, the corresponding frequency value is loaded respectively. This does not affect VOR and MB.

4.2.3 VAR Function

The relevant parameters can be varied using the VAR spinwheel. The parameters are preset to the smallest possible step size or, if present, to a table of values (RF, DDM) which are loaded one after the other. If the parameters are varied via the keypad, rotating the VAR spinwheel causes the next values from the table to be loaded. If a new step size is entered, the table cannot be accessed. The table can be activated again by entering a step size of zero. The AF modulations and AF frequencies displayed in each of the four menus are specified standard values which can, however, be varied for simulation of deviations and faults.

4.2.4 Presettings

Varied parameters in the VOR, ILS and MB menus can be reset to their standard values using the key combination SHIFT / RESET (cf. table 2, page 20); however, this effects entering the SELECT menu again.

4.3 VOR Menu

| | | | | |
|---|------------------------------------|--|-----------|-----------------------|
| 0 | VOR CMS - Local HARDCOPY | | | 8 |
| 1 | SET RF | 108.00000 MHz | | AF MODE 9 |
| 2 | RF LEV AF REF | 1.000 uV  | | 10 |
| 3 | 30Hz VAR | 30.0 % | 30.0 Hz | VAR VAR F 11 |
| 4 | 9960Hz CARRIER | 30.0 % | 9960.0 Hz | CARRIER CARR. F 12 |
| 5 | 9960Hz FM | | 480 Hz | MOD FM 13 |
| 6 | 1020Hz AUX | 0.0 % | 1020.0 Hz | AUX AUX F 14 |
| 7 | PHASE | 0.00 ° | TO FROM | DIRECT. 15 |

Fig. 7 VOR Menu

Softkey 3: 30 Hz VAR

This softkey activates the phase-variable 30-Hz tone. It is active when the field is inverted.

Softkey 4: 9960 Hz CARRIER

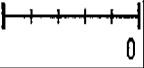
This softkey activates the unmodulated subcarrier. It is active when the field is inverted.

Softkey 5: 9960 Hz FM

This softkey activates the FM-modulated subcarrier. Softkeys 4 and 5 cannot be active simultaneously, i.e. switching on the modulated subcarrier automatically disables the unmodulated carrier. Softkey 5 is active when the field is inverted.

Softkey 6: 1020 Hz AUX

This softkey switches on the auxiliary tone. It is active when the field is inverted.

Softkey 7: PHASE

This function sets the phase of the 30-Hz signal. The entry is made using *Softkey 7/number/ENTER*. The phase value is indicated in degrees. The step size of the VAR spinwheel is preset to 10°.

The softkeys 11 to 14 are used for entering the frequency using *Softkey/number/dimension* or *ENTER* and for entering the modulation using *Softkey/number/%* or *ENTER*. The modulation is displayed in percent.

Softkey 11: VAR/VAR F

Dual function for entering the frequency and modulation of the phase-variable 30-Hz signal.

Softkey 12: CARRIER/CARR. F

Dual function for entering the frequency and modulation of the subcarrier.

Softkey 13: MOD FM

Entry of the frequency deviation for the FM modulation of the subcarrier.

Softkey 14: AUX/AUX F

Dual function for entering the frequency and modulation of the auxiliary tone.

Softkey 15: DIRECT.

Softkey with toggle function for switching over the direction TO/FROM. If TO is inverted the internal phase is additionally shifted by 180°. This does not affect display of the phase.

4.4 ILS Menu

| | | | | | |
|---|------------------|------------------|---|----------------|----|
| 0 | ILS-GS | ILS-LOC | CMS - Local HARDCOPY | MB | 8 |
| 1 | SET RF | 108.10000 MHz | | RF MODE | 9 |
| 2 | RF LEV RF REF | -47.0 dBm |  | | 10 |
| 3 | PHASE | 180.00 ° | 20.0 % | MOD | 11 |
| 4 | 90Hz | 90.0 Hz | | 90Hz VAR F | 12 |
| 5 | 150Hz | 150.0 Hz | | 150Hz VAR F | 13 |
| 6 | 1020Hz AUX | 0.0 % | 1020.0 Hz | AUX AUX F | 14 |
| 7 | DDM | -0.200 (-194 uA) | RIGHT LEFT | HORIZON. | 15 |

Fig. 8 ILS-LOC Menu

| | | | | | |
|---|------------------|--|---|----------------|----|
| 0 | ILS-LOC | ILS-GS | CMS - Local HARDCOPY | MB | 8 |
| 1 | SET RF | 334.70000 MHz (LOC-FREQ: 108.10000 MHz) | | RF MODE | 9 |
| 2 | RF LEV RF REF | -60.0 dBm |  | | 10 |
| 3 | PHASE | 90.00 ° | 40.0 % | MOD | 11 |
| 4 | 90Hz | 90.0 Hz | | 90Hz VAR F | 12 |
| 5 | 150Hz | 150.0 Hz | | 150Hz VAR F | 13 |
| 6 | 1020Hz AUX | 0.0 % | 1020.0 Hz | AUX AUX F | 14 |
| 7 | DDM | -0.400 (-343 uA) | DOWN UP | VERTICAL | 15 |

Fig. 9 ILS-GS Menu

The two menus ILS-LOC and ILS-GS are identical concerning arrangement and function, except for softkeys 0 and 15 which are labelled differently. The default parameters are, however, different.

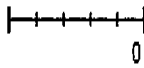
The ILS-LOC and ILS-GS RF frequencies are allocated in pairs (cf. table 1, page 19). When changing these frequencies via softkey 1, the new allocated frequency is used when entering the respective other menu. The allocated LOC frequency is additionally displayed in the ILS-GS menu.

The frequency ratio of the ILS signals "90 Hz" and "150 Hz" is always 3/5. Thus, changing the frequency of one signal automatically changes the frequency of the other signal proportionally. Both signals are phase-locked. The phasing is set using the PHASE parameter.

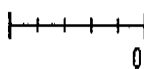
Softkey 3: PHASE

This function is used for setting the phase between the 90-Hz and the 150-Hz signals. The entry is made using `Softkey 3/number/ENTER`.

Softkey 4: 90 Hz

This softkey enables the 90-Hz tone. It is active, when the field is inverted.

Softkey 5: 150 Hz

This softkey enables the 150-Hz tone. It is active, when the field is inverted.

Softkey 6: 1020 Hz AUX

This softkey enables the auxiliary tone. It is active, when the field is inverted.

Softkey 7: DDM

This function is used for entering the modulation difference between the 90-Hz signal and the 150-Hz signal.

$$\text{DDM} = (90\text{-Hz modulation} - 150\text{-Hz modulation}) / 100\% \quad \text{with RIGHT or DOWN}$$

$$\text{DDM} = (150\text{-Hz modulation} - 90\text{-Hz modulation}) / 100\% \quad \text{with LEFT or UP}$$

Calculation of the modulation of individual tones:

$$90\text{-Hz modulation} = \text{MOD} + / (-) \text{ DDM}/2 * 100 \% \quad \text{with RIGHT or DOWN (with LEFT or UP)}$$

$$150\text{-Hz modulation} = \text{MOD} - / (+) \text{ DDM}/2 * 100 \%$$

Rotating the VAR spinwheel calls the subsequent table of values for the localizer and the glide slope, respectively. DDM can be varied in positive and negative direction.

| ILS-LOC | ILS-GS |
|-------------------------|------------------------|
| 0.000 (Course Line) | 0.000 (Glide Path) |
| ± 0.046 | ± 0.045 |
| ± 0.093 | ± 0.091 |
| ± 0.155 (Course Sector) | ± 0.175 (Glide Sector) |
| ± 0.200 | ± 0.400 |

Any step width can be set by means of <VAR>, number, <ENTER>.

The current corresponding to the DDM value (in μA), which is used for calibration of conventional moving-coil instruments, is indicated in brackets after the DDM value. Being useful for servicing purposes (adjustment works) only, the current is output exclusively on the display and not via IEC bus or in the autorun report.

Softkey 10: AUTOPILOT (with option CMS-B38 only)

This softkey appears only when the CMS is fitted with a second RF output. On pressing this softkey a modulated glide-slope signal is made available provided option CMS-B38 is built in. In this case, the frequency setting appears next to softkey 10 as shown in Fig. 8. A glide-slope signal is output and displayed only if the localizer frequency to be entered by means of softkey 1 corresponds to a standard value in Table 1. If a new standard frequency is selected with softkey 1 via the rollkey or directly entered, the glide slope frequency varies in line with the standard (Table 1). If a frequency is selected out of the standard range, the glide-slope signal is switched off. This state is indicated on the display by the symbol "----".

The modulation of the glide slope synthesizer is carried out together with the localizer frequency using softkeys 11 to 13. The specifications of the GS synthesizer (as shown on Fig. 9) do not apply to option CMS-B38.

The softkeys 11 to 14 are used for entering the frequency using `Softkey/number/dimension` or `ENTER` and for entering the modulation using `Softkey/number/%` or `ENTER`. The modulation is displayed in percent.

Softkey 11: MOD

This function is used for setting the modulations of the 90-Hz signal and the 150-Hz signal. MOD indicates the arithmetic average of the modulation of the two signals.

$$\text{MOD} = (\text{90-Hz modulation} + \text{150-Hz modulation}) / 2$$

Softkey 12: 90 Hz VAR F and Softkey 13: 150 Hz VAR F

These functions are used for changing the frequencies of the 90-Hz and 150-Hz signal.

Softkey 14: AUX/AUX F

Dual function for entering the frequency and the modulation of the auxiliary tone.

Softkey 15: L/R (ILS-LOC) or U/D (ILS-GS)

Softkey with toggle function for converting the modulation of the 90-Hz and the 150-Hz tones.

| Menu Tone | ILS-LOC | ILS-GS |
|--------------|---------|--------|
| 90 Hz | RIGHT | DOWN |
| 150 Hz | LEFT | UP |

Assigning the higher modulation to one of the two tones.

4.5 Marker Beacon Menu (MB)

| | | | | | |
|---|------------------|-------------------------------|---|-----------------|----|
| 0 | ILS-GS | MB | CMS - Local HARDCOPY | ILS-LOC | 8 |
| 1 | SET RF | 75.00000 MHz | 0.0 mV | AF LEV | 9 |
| 2 | RF LEV AF REF | 1.000 μ V | RMS +0.025 | DC - VOLTAGE | 10 |
| 3 | | | AF AMP: 50 mV/ \square TIME: 0.2 ms/ \square | SCOPE MODE | 11 |
| 4 | MB F | 400 Hz 1300 Hz 3000 Hz OFF | | BEST RANGE | 12 |
| 5 | MB LEV | 95.0 % | | AMP | 13 |
| 6 | 1020Hz AUX | | | TIME | 14 |
| 7 | AUX AUX F | 1020.0 Hz 0.0 % | | Y POS | 15 |

Fig. 10 MB menu

Softkey 4: MB F

This toggle function is used for selecting one of the three AF frequencies for the marker beacon. The tone is switched off in the OFF position.

Softkey 5: MB LEV

This function sets the modulation of the marker beacon tones. The entry is made using Softkey/number/% or ENTER.

Softkey 6: 1020 Hz AUX

This softkey switches on the auxiliary tone. It is active when the field is inverted.

Softkey 7: AUX/AUX F

This function is used for setting the modulation and frequency of the auxiliary tone. The frequency is entered using Softkey 7/number/dimension or ENTER. Entry of modulation is made using Softkey 7/number/% or ENTER.

Table 1 Standard frequencies of the RF carriers

| VOR frequencies [MHz] | | | ILS frequencies paired | | Marker beacon frequencies [MHz] |
|-----------------------|--------|--------|------------------------|--------------------|---------------------------------|
| | | | LOCALIZER [MHz] | GLIDESLOPE [MHz] | |
| 108.00 | 112.70 | 115.40 | 108.10 | 334.70 | 74.600 |
| 108.05 | 112.75 | 115.45 | 108.15 | 334.55 | 74.625 |
| 108.20 | 112.80 | 115.50 | 108.30 | 334.10 | 74.650 |
| 108.25 | 112.85 | 115.55 | 108.35 | 333.95 | 74.675 |
| 108.40 | 112.90 | 115.60 | 108.50 | 329.90 | 74.700 |
| 108.45 | 112.95 | 115.65 | 108.55 | 329.75 | 74.725 |
| 108.60 | 113.00 | 115.70 | 108.70 | 330.50 | 74.750 |
| 108.65 | 113.05 | 115.75 | 108.75 | 330.35 | 74.775 |
| 108.80 | 113.10 | 115.80 | 108.90 | 329.30 | 74.800 |
| 108.85 | 113.15 | 115.85 | 108.95 | 329.15 | 74.825 |
| 109.00 | 113.20 | 115.90 | 109.10 | 331.40 | 74.850 |
| 109.05 | 113.25 | 115.95 | 109.15 | 331.25 | 74.875 |
| 109.20 | 113.30 | 116.00 | 109.30 | 332.00 | 74.900 |
| 109.25 | 113.35 | 116.05 | 109.35 | 331.85 | 74.925 |
| 109.40 | 113.40 | 116.10 | 109.50 | 332.60 | 74.950 |
| 109.45 | 113.45 | 116.15 | 109.55 | 332.45 | 74.975 |
| 109.60 | 113.50 | 116.20 | 109.70 | 333.20 | 75.000 |
| 109.65 | 113.55 | 116.25 | 109.75 | 333.05 | 75.025 |
| 109.80 | 113.60 | 116.30 | 109.90 | 333.80 | 75.050 |
| 109.85 | 113.65 | 116.35 | 109.95 | 333.65 | 75.075 |
| 110.00 | 113.70 | 116.40 | 110.10 | 334.40 | 75.100 |
| 110.05 | 113.75 | 116.45 | 110.15 | 334.25 | 75.125 |
| 110.20 | 113.80 | 116.50 | 110.30 | 335.00 | 75.150 |
| 110.25 | 113.85 | 116.55 | 110.35 | 334.85 | 75.175 |
| 110.40 | 113.90 | 116.60 | 110.50 | 329.60 | 75.200 |
| 110.45 | 113.95 | 116.65 | 110.55 | 329.45 | 75.225 |
| 110.60 | 114.00 | 116.70 | 110.70 | 330.20 | 75.250 |
| 110.65 | 114.05 | 116.75 | 110.75 | 330.05 | 75.275 |
| 110.80 | 114.10 | 116.80 | 110.90 | 330.80 | 75.300 |
| 110.85 | 114.15 | 116.85 | 110.95 | 330.65 | 75.325 |
| 111.00 | 114.20 | 116.90 | 111.10 | 331.70 | 75.350 |
| 111.05 | 114.25 | 116.95 | 111.15 | 331.55 | 75.375 |
| 111.20 | 114.30 | 117.00 | 111.30 | 332.30 | 75.400 |
| 111.25 | 114.35 | 117.05 | 111.35 | 332.15 | |
| 111.40 | 114.40 | 117.10 | 111.50 | 332.90 | |
| 111.45 | 114.45 | 117.15 | 111.55 | 332.75 | |
| 111.60 | 114.50 | 117.20 | 111.70 | 333.50 | |
| 111.65 | 114.55 | 117.25 | 111.75 | 333.35 | |
| 111.80 | 114.60 | 117.30 | 111.90 | 331.10 | |
| 111.85 | 114.65 | 117.35 | 111.95 | 330.95 | |
| 112.00 | 114.70 | 117.40 | | | |
| 112.05 | 114.75 | 117.45 | | | |
| 112.10 | 114.80 | 117.50 | | | |
| 112.15 | 114.85 | 117.55 | | | |
| 112.20 | 114.90 | 117.60 | | | |
| 112.25 | 114.95 | 117.65 | | | |
| 112.30 | 115.00 | 117.70 | | | |
| 112.35 | 115.05 | 117.75 | | | |
| 112.40 | 115.10 | 117.80 | | | |
| 112.45 | 115.15 | 117.85 | | | |
| 112.50 | 115.20 | 117.90 | | | |
| 112.55 | 115.25 | 117.95 | | | |
| 112.60 | 115.30 | | | | |
| 112.65 | 115.35 | | | | |
| VOR menu | | | ILS-LOC menu | ILS-GS menu | MB menu |

Table 2 Presetting standard values

| Parameter | Value displayed | Presetting Δ VAR |
|--|-----------------|-------------------------------|
| VOR, ILS-LOC, ILS-GS and MB menu: | | |
| RF LEV | 1 μ V | 0,1 dBm |
| AF REF | 1 mV | 0,1 mV |
| VOR menu: | | |
| 30 Hz VAR | ON | -- |
| 9960 Hz CARRIER | OFF | -- |
| 9960 Hz FM | ON | -- |
| 1020 Hz AUX | OFF | -- |
| PHASE | 0,00 ° | 10 ° |
| VAR | 30 % | 0,1 % |
| VAR F | 30 Hz | 0,1 Hz |
| CARRIER | 30 % | 0,1 % |
| CARR. F | 9960 Hz | 1 Hz |
| MOD FM | 480 Hz | 1 Hz |
| AUX | 20 % | 0,1 % |
| AUX F | 1020 Hz | 1 Hz |
| DIRECT. | FROM | -- |
| SET RF | 108.0 MHz | cf. table 1 |
| ILS-LOC and ILS-GS menu: | | |
| PHASE | 0 ° | 1 ° |
| 90 Hz VAR F | 90 Hz | 0,1 Hz |
| 150 Hz VAR F | 150 Hz | 0,1 Hz |
| ILS-LOC menu: | | |
| SET RF | 108,10 MHz | cf. table 1 |
| AUTOPILOT | 334,70 MHz | with SET RF |
| 90 Hz | ON | -- |
| 150 Hz | ON | -- |
| 1020 Hz AUX | OFF | -- |
| DDM | 0,000 | cf. ILS menu, softkey 7 (DDM) |
| MOD | 20 % | 0,1 % |
| AUX | 20 % | 0,1 % |
| AUX F | 1020 Hz | 0,1 Hz |
| L/R | LEFT | -- |
| ILS-GS menu: | | |
| SET RF | 334,70 MHz | cf. table 1 |
| 90 Hz | ON | -- |
| 150 Hz | ON | -- |
| 1020 Hz AUX | OFF | -- |
| DDM | 0,000 | cf. ILS menu, softkey 7 (DDM) |
| MOD | 40 % | 0,1 % |
| AUX | 5 % | 0,1 % |
| AUX F | 1020 Hz | 0,1 Hz |
| U/D | UP | -- |
| MB menu: | | |
| SET RF | 74,6 MHz | cf. table 1 |
| MB F | 400 Hz | -- |
| MB LEV | 95,0 % | 0,1 % |
| 1020 Hz AUX | OFF | -- |
| AUX | 5 % | 0,1 % |
| AUX F | 1020 Hz | 1 Hz |

5 IEC-Bus Commands for VOR/ILS Signal Generator

VOR

| Command | Data | Units | Function |
|---------------------------------|---------------|------------|---|
| VOR:AF | number | Mv Uv V | AF reference level |
| VOR:AF:VARIATION | number ON OFF | Mv Uv V | |
| VOR:AUX:FREQUENCY | number | KHz Hz MHz | Frequency setting of the auxiliary tone |
| VOR:AUX:FREQUENCY:VARIATION | number ON OFF | KHz Hz MHz | |
| VOR:AUX:LEVEL | number | PCT | Modulation of the auxiliary tone |
| VOR:AUX:LEVEL:VARIATION | number ON OFF | PCT | |
| VOR:AUX:TOGGLE | ON OFF | | Auxiliary tone on/off |
| VOR:MOD:FM | number | KHz Hz MHz | Frequency deviation of subcarrier |
| VOR:MOD:FM:VARIATION | number ON OFF | KHz Hz MHz | |
| VOR:CARRIER:FREQUENCY | number | KHz Hz MHz | Frequency of subcarrier |
| VOR:CARRIER:FREQUENCY:VARIATION | number ON OFF | KHz Hz MHz | |
| VOR:CARRIER:TOGGLE | ON OFF | | Unmodulated subcarrier on/off |
| VOR:CARRIER:LEVEL | number | PCT | Modulation of subcarrier |
| VOR:CARRIER:LEVEL:VARIATION | number ON OFF | PCT | |
| VOR:VAR:LEVEL | number | PCT | Modulation of the phase-variable signal |
| VOR:VAR:LEVEL:VARIATION | number ON OFF | PCT | |
| VOR:VAR:FREQUENCY | number | KHz Hz MHz | Frequency of the phase-variable signal |
| VOR:VAR:FREQUENCY:VARIATION | number ON OFF | KHz Hz MHz | |
| VOR:VAR:TOGGLE | ON OFF | | Phase-variable signal on/off |
| VOR:MODFM:TOGGLE | ON OFF | | Modulated subcarrier on/off |
| VOR:PHASE | number | | Phase shift |
| VOR:PHASE:VARIATION | number ON OFF | | |
| VOR:DIRECTION | TO FROM | | Switchover TO/FROM |

ILS Localizer

| Command | Data | Units | Function |
|-------------------------------------|---------------|------------|---|
| ILS:LOC:AF | number | MV Uv V | AF reference level |
| ILS:LOC:AF:VARIATION | number ON OFF | MV Uv V | |
| ILS:LOC:PHASE | number | | Phase shift |
| ILS:LOC:PHASE:VARIATION | number ON OFF | | |
| ILS:LOC:F90Hz:TOGGLE | ON OFF | | 90-Hz tone on/off |
| ILS:LOC:F90Hz:FREQUENCY | number | KHz Hz MHz | Frequency setting for the 90-Hz tone |
| ILS:LOC:F90Hz:FREQUENCY:VARIATION | number ON OFF | KHz Hz MHz | |
| ILS:LOC:DDM | number | | DDM setting |
| ILS:LOC:DDM:VARIATION | number ON OFF | | |
| ILS:LOC:MODULATION | number | PCT | Modulation of the 90-Hz-/150-Hz tone |
| ILS:LOC:MODULATION:VARIATION | number ON OFF | PCT | |
| ILS:LOC:AUTOPILOT | ON OFF | | GS synth. on/off |
| ILS:LOC:F150 HZ:TOGGLE | ON OFF | | 150-Hz tone on/off |
| ILS:LOC:F150 HZ:FREQUENCY | number | KHz Hz MHz | Frequency setting for the 150-Hz tone |
| ILS:LOC:F150 HZ:FREQUENCY:VARIATION | number ON OFF | KHz Hz MHz | |
| ILS:LOC:AUX:TOGGLE | ON OFF | | Auxiliary tone on/off |
| ILS:LOC:AUX:FREQUENCY | number ON OFF | KHz Hz MHz | Frequency setting for the auxiliary tone |
| ILS:LOC:AUX:FREQUENCY:VARIATION | | KHz Hz MHz | |
| ILS:LOC:AUX:LEVEL | number | PCT | Modulation of the auxiliary tone |
| ILS:LOC:AUX:LEVEL:VARIATION | number ON OFF | PCT | |
| ILS:LOC:LEFTRIGHT | LEFT RIGHT | | Higher modulation with DDM referred to 150-Hz tone (right) or 90-Hz tone (left) |

ILS Glide Slope

| Command | Data | Units | Function |
|---|----------------------|-------------------|--|
| ILS:Gs:AF | number | Mv Uv V | AF reference level |
| ILS:Gs:AF:VARIATION | number ON OFF | Mv Uv V | |
| ILS:Gs:PHASE | number | | Phase shift |
| ILS:Gs:PHASE:VARIATION | number ON OFF | | |
| ILS:Gs:F90Hz:TOGGLE | ON OFF | | 90-Hz tone on/off |
| ILS:Gs:F90Hz:FREQUENCY | number | KHz Hz MHz | Frequency setting for the 90-Hz tone |
| ILS:Gs:F90Hz:FREQUENCY:VARIATION | number ON OFF | KHz Hz MHz | |
| ILS:Gs:DDM | number | | DDM setting |
| ILS:Gs:DDM:VARIATION | number ON OFF | | |
| ILS:Gs:MODULATION | number | PCT | Modulation of the 90-Hz-/150-Hz tone |
| ILS:Gs:MODULATION:VARIATION | number ON OFF | PCT | |
| ILS:Gs:F150 Hz:TOGGLE | ON OFF | | 150-Hz tone on/off |
| ILS:Gs:F150 Hz:FREQUENCY | number | KHz Hz MHz | Frequency setting for the 150-Hz tone |
| ILS:Gs:F150 Hz:FREQUENCY:VARIATION | number ON OFF | KHz Hz MHz | |
| ILS:Gs:AUX:TOGGLE | ON OFF | | Auxiliary tone on/off |
| ILS:Gs:AUX:FREQUENCY | number | KHz Hz MHz | Frequency setting for the auxiliary tone |
| ILS:Gs:AUX:FREQUENCY:VARIATION | number ON OFF | KHz Hz MHz | |
| ILS:Gs:AUX:LEVEL | number | PCT | Modulation of the auxiliary tone |
| ILS:Gs:AUX:LEVEL:VARIATION | number ON OFF | PCT | |
| ILS:Gs:UPDOWN | UP DOWN | | Higher modulation with DDM referred to 150-Hz tone (down) or 90-Hz tone (up) |

Marker Beacon

| Command | Data | Units | Function |
|-----------------------------------|---|-------------------|---|
| MB:AF | number | Mv Uv V | AF reference level |
| MB:AF:VARIATION | number ON OFF | Mv Uv V | |
| MB:FREQUENCY:TOGGLE | SEL _ 400 HZ SEL _ 1300 HZ SEL _ 3000 HZ OFF | | AF frequencies of marker beacon (400 Hz, 1.3 kHz, 3 kHz or OFF) |
| MB:LEVEL | number | PCT | Marker beacon modulation |
| MB:LEVEL:VARIATION | number ON OFF | PCT | |
| MB:AUX:TOGGLE | ON OFF | | Auxiliary tone on/off |
| MB:AUX:FREQUENCY | number | KHz Hz MHz | Frequency setting of the auxiliary tone |
| MB:AUX:FREQUENCY:VARIATION | number ON OFF | KHz Hz MHz | |
| MB:AUX:LEVEL | number | PCT | Modulation of the auxiliary tone |
| MB:AUX:LEVEL:VARIATION | number ON OFF | PCT | |

| Main menu | | Submenu | |
|-----------|--------------|---------|---------|
| Index | Name | Index | Name |
| 17 | VOR menu | 65 | AF MODE |
| 18 | ILS-LOC menu | | |
| 19 | ILS-GS menu | | |
| 20 | MB menu | | |

6 Performance Test

6.1 Required Measuring Instruments and Accessories

| Item No. | <ul style="list-style-type: none"> ○ Type of Instrument, Required Data ● Recommended R&S Instrument | Type | Order No. | Application Section |
|----------|---|------|-------------|---------------------|
| 1 | <ul style="list-style-type: none"> ○ Modulation analyzer 70 to 350 MHz AM Distortion meter for the demodulated signal and external AF signals ● Modulation Analyzer | FMAV | 856.4509.52 | 6.2.2 |
| 2 | <ul style="list-style-type: none"> ○ RMS voltmeter (true RMS) 10 Hz to 20 kHz Resolution = 100 μV ● RMS Voltmeter | URE | 342.1214.02 | 6.2.6 |
| 3 | <ul style="list-style-type: none"> ○ ILS test receiver for evaluation of the DDM | FMAV | 856.4509.52 | 6.2.5 |
| 4 | <ul style="list-style-type: none"> ○ VOR phase meter | FMAV | 856.4509.52 | 6.2.3 |
| 5 | <ul style="list-style-type: none"> ○ Oscilloscope | | | 6.2.4 |

6.2 Testing the Rated Specifications

6.2.1 General Information

All the settings not stated below must be set to their preset values. Reset them by pressing the keys SHIFT and RESET.

6.2.2 AM Modulation and AM Distortion

The modulation analyzer is connected to the RF IN/OUT socket.

VOR:

-9 dBm, 113.0 MHz

Switch on the tones 30 Hz VAR, 9960 Hz CARRIER and 1020 Hz AUX separately. Measure the modulation and AM distortion.

ILS-LOC:

-9 dBm, 110.1 MHz

Switch on the tones 90 Hz, 150 Hz and 1020 Hz AUX separately. Measure the modulation and AM distortion.

ILS-GS:

-9 dBm, 332.0 MHz

Switch on the tones 90 Hz, 150 Hz and 1020 Hz AUX separately. Measure the modulation and AM distortion.

With AM modulation of the VOR- and ILS-signals, deviation from the nominal value must not be higher than 2 % or 3%. AM distortion may be max. 2 %.

MB:

-9 dBm, 70.0 MHz

Switch on the tones 400 Hz, 1300 Hz and 3000 Hz separately. Measure the modulation.

With AM modulation, deviation from the nominal value must not be higher than 5 %.

6.2.3 VOR Phase

The VOR phase meter is connected to the MOD GEN socket.

VOR:

AF REF = 2 V; MOD FM = 480 Hz

The tones 30 Hz VAR and 9960 Hz FM must be switched on. The phase is measured at 0°. Deviation must not be higher than 0.04°.

6.2.4 ILS Phase

ILS-GS:

AF REF = 2 V

DDM = 0.000

PHASE = 120.00°

Connect the oscilloscope to the MOD GEN socket. The input must be d.c. coupled. Set the time base, amplitude excursion and triggering such that the two lower amplitude peaks of the characteristic ILS signal are displayed optimally magnified on the screen (cf. fig. 11). With a phase shift of 0° and 120° the two peaks must be equally high. Otherwise the peaks can be made equally high by way of fine variation of the phase (VAR 0.1°). Deviation from 0° and/or 120° must not be higher than ±1°.

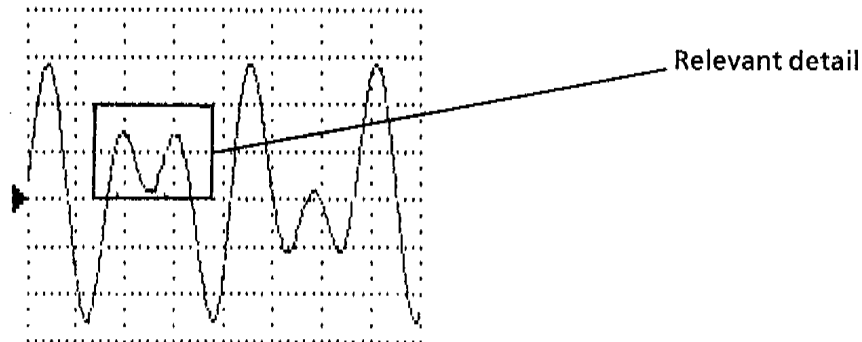

Fig. 11 ILS signal at the AF output (MOD GEN)

6.2.5 DDM Measurement at the RF Output with ILS Signals

RF LEV = -30 dBm

Both modulation tones 90 Hz and 150 Hz are switched on. Depending on the ILS test receiver used the DDM value is either directly measured or calculated using the selectively measured modulation depths of both tones.

The DDM value is obtained using the following formula:

$DDM = (90\text{-Hz modulation} - 150\text{-Hz modulation}) / 100\%$ if toggle LEFT/RIGHT is set to RIGHT (ILS-LOC)
or toggle UP/DOWN to UP (ILS-GS).

ILS-LOC menu:

The DDM value may deviate from the displayed value by ±(2 % + 0.0004 DDM).

ILS-GS menu:

The DDM value may deviate from the displayed value by ±(2 % + 0.001 DDM).

6.2.6 DDM Measurement at the AF Output with ILS Signals

AF REF = 3.5 V

The levels of the individual tones are measured at the MOD GEN output using the RMS voltmeter. The 90-Hz and 150-Hz tone are switched on separately.

The DDM value is obtained using the following formula:

$DDM = (90\text{-Hz level} - 150\text{-Hz level}) / AF\ REF$ if toggle LEFT/RIGHT is set to RIGHT (ILS-LOC) or toggle UP/DOWN to UP (ILS-GS).

In the ILS-LOC menu and ILS-GS menu the deviation from the displayed DDM value must not be higher than 3 % + 0.0002 DDM.

6.3 Performance Test Report

ROHDE & SCHWARZ
 RADIOCOMMUNICATION SERVICE MONITOR CMS*)
 Order. No. 840.0009*)
 F. Nr.

Date
 Name

*)for certain models

| Item no. | Characteristic | Measurement to section | Min. | Actual | Max. | Unit |
|----------|---|------------------------|-------------|----------------|--------------|--------|
| 1 | AM modulation | 6.2.2 | | | | |
| | VOR: | | | | | |
| | 30 Hz VAR Modulation = 30 % | | 29.4 | | 30.6 | % |
| | 9960 Hz CARRIER Modulation = 30 % | | 29.4 | | 30.6 | % |
| | 1020 Hz AUX Modulation = 20 % Modulation = 10 % | | 19.4 9.7 | | 20.6 10.3 | % % |
| | I LS-LOC: | | | | | |
| | 90 Hz, DDM = 0.0 Modulation 20 % | | 19.6 | | 20.4 | % |
| | 150 Hz, DDM = 0.0 Modulation = 20 % | | 19.6 | | 20.4 | % |
| | 1020 Hz AUX Modulation = 20 % Modulation = 10 % | | 19.4 9.7 | | 20.6 10.3 | % % |
| | I LS-GS: | | | | | |
| | 90 Hz, DDM = 0.0 Modulation = 40 % | | 39.2 | | 40.8 | % |
| | 150 Hz, DDM = 0.0 Modulation = 40 % | | 39.2 | | 40.8 | % |
| | 1020 Hz AUX Modulation = 20 % Modulation = 10 % | | 19.4 9.7 | | 20.6 10.3 | % % |
| | MB: | | | | | |
| | MB = 400 Hz MB modulation = 95 % | | 90.25 | | 99.75 | % |
| | MB = 1300 Hz MB modulation = 95 % | | 90.25 | | 99.75 | % |
| | MB = 3000 Hz MB modulation = 95 % | | 90.25 | | 99.75 | % |

| Item no. | Characteristic | Measurement to section | Min. | Actual | Max. | Unit |
|----------------|--|------------------------|---------|--------|---------|------|
| 2 | AM distortion | 6.2.2 | | | | |
| | <i>VOR:</i> | | | | | |
| | 30 Hz VAR | | --- | | 2 | % |
| | 9960 Hz CARRIER | | --- | | 2 | % |
| | 1020 Hz AUX | | | | | |
| | Modulation 20 % | | --- | | 2 | % |
| | Modulation 10 % | | --- | | 2 | % |
| | <i>ILS-LOC:</i> | | | | | |
| | 90 Hz | | --- | | 2 | % |
| | 150 Hz | | --- | | 2 | % |
| <i>ILS-GS:</i> | | | | | | |
| 90 Hz | --- | | 2 | % | | |
| 150 Hz | --- | | 2 | % | | |
| 3 | VOR phase (AF) Phase = 0 ° | 6.2.3 | -0.04 | | 0.04 | ° |
| 4 | ILS phase (AF) Phase = 120 ° | 6.2.4 | 119 | | 121 | ° |
| 5 | DDM (RF) | 6.2.5 | | | | |
| | <i>ILS-LOC:</i> | | | | | |
| | DDM = 0.0 | | -0.0004 | | +0.0004 | --- |
| | DDM = 0.2 | | 0.1956 | | 0.2044 | --- |
| | <i>ILS-GS:</i> | | | | | |
| | DDM = 0.0 | | -0.001 | | +0.001 | --- |
| DDM = 0.4 | 0.391 | | 0.409 | --- | | |
| 6 | DDM (AF) | 6.2.6 | | | | |
| | <i>ILS-LOC:</i> | | | | | |
| | DDM = 0.0 | | -0.0002 | | 0.0002 | --- |
| | DDM = 0.2 | | 0.1938 | | 0.2062 | --- |
| | <i>ILS-GS:</i> | | | | | |
| | DDM = 0.0 | | -0.0002 | | 0.0002 | --- |
| DDM = 0.2 | 0.1938 | | 0.2062 | --- | | |

